

2014

RELEASED FOR PUBLICATION

THIS DRAWING IS UNPUBLISHED.

ALL RIGHTS RESERVED.

© COPYRIGHT 2014 BY TE CONNECTIVITY

REVISIONS

P	LTR	DESCRIPTION	DATE	DWN	APVD
A		NEW RELEASE PER ECO-14-012854	08-20-14	DM	DM

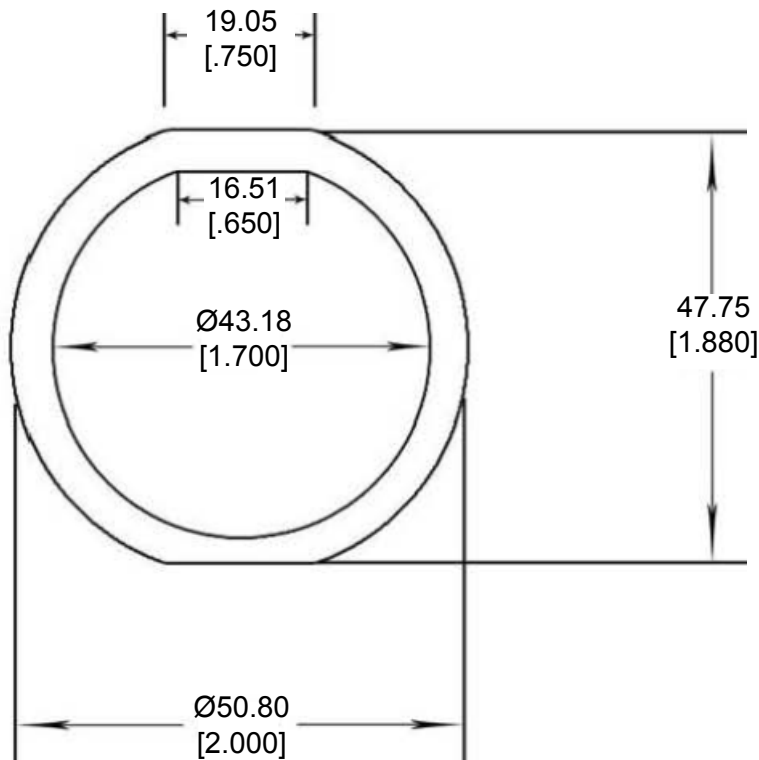

4. THICKNESS: 3.18 [.125]
3. PART NO. 16-04477
2. TEMPERATURE RATING: -57°C TO +107°C [-70°F TO +225°F]
1. THIS PART IS USED ON HDP20 / HD30 SIZE 24 RECEPTACLES.

DIMENSIONS: <b>MM [INCH]</b>	DWN D. MEYER 20AUG2014	MATERIAL CLD CELL SPONGE	FINISH BLACK		
	CHK I. GRANTCHARVORA 20AUG2014	 TE Connectivity			
TOLERANCES UNLESS OTHERWISE SPECIFIED:	APVD D. MEYER 20AUG2014			NAME GASKET, RECEPTACLE, SIZE 24 HDP20 / HD30 SERIES	
0 PLC ±	PRODUCT SPEC	SIZE A 4	CAGE CODE 4AFU8	DRAWING NO C-16-04477	RESTRICTED TO -
1 PLC ±	APPLICATION SPEC	WEIGHT .45 g		Customer Drawing	
2 PLC ± 0.76 [.030]		SCALE NONE	SHEET 1 OF 1	REV A	
3 PLC ±					
4 PLC ±					
ANGLES ± 5°					

