

修订 REV	标记 MARK	修改摘要 REVISION DESCRIPTION	签名 SIGNATURE	日期 DATE
AO		NEW RELEASE	黄艳兰	2021-05-09

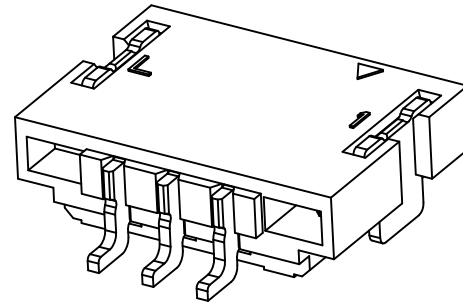

Specifications:

Contact resistance: $\leq 20m\Omega$
 Insulation resistance: $\geq 100M\Omega$
 Rated voltage: 50V AC DC
 Rated current: 1.0A AC DC
 Withstand Voltage: 500V AC/minute
 Temperature Range: $-25^{\circ}C \sim +85^{\circ}C$
 Housing: PA6T UL94V-0, Natural (Beige)
 Contacts: Phosphor bronze/Matte Sn
 Solder Tabs: Phosphor bronze/Matte Sn

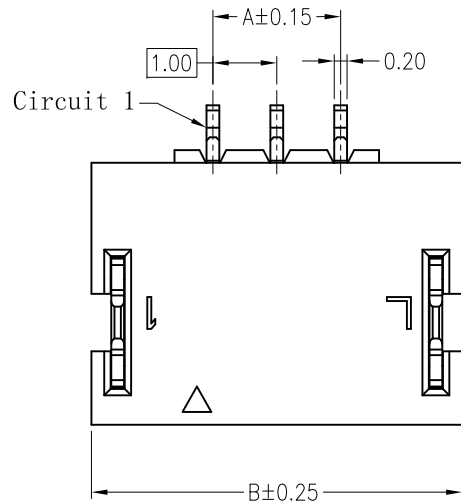
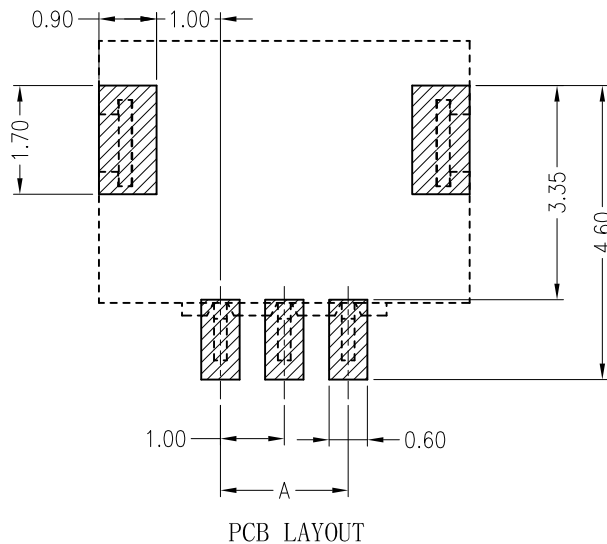
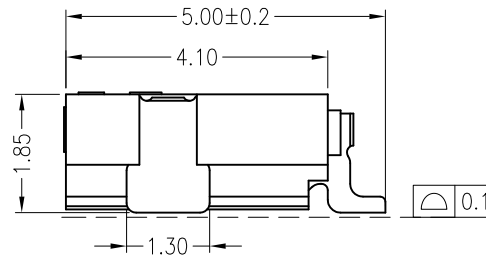
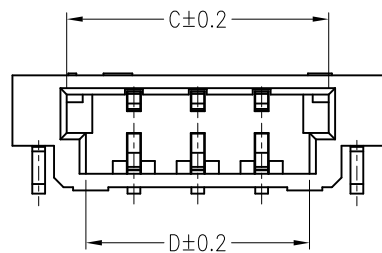

Circuits	Dimensions (mm)				Circuits	Dimensions (mm)			
	A	B	C	D		A	B	C	D
02	1.00	4.80	3.10	2.50	*17	16.00	19.80	18.10	17.50
03	2.00	5.80	4.10	3.50	*18	17.00	20.80	19.10	18.50
04	3.00	6.80	5.10	4.50	*19	18.00	21.80	20.10	19.50
05	4.00	7.80	6.10	5.50	*20	19.00	22.80	21.10	20.50
06	5.00	8.80	7.10	6.50	*21	20.00	23.80	22.10	21.50
07	6.00	9.80	8.10	7.50	*22	21.00	24.80	23.10	22.50
08	7.00	10.80	9.10	8.50	*23	22.00	25.80	24.10	23.50
*09	8.00	11.80	10.10	9.50	*24	23.00	26.80	25.10	24.50
*10	9.00	12.80	11.10	10.50	*25	24.00	27.80	26.10	25.50
*11	10.00	13.80	12.10	11.50	*26	25.00	28.80	27.10	26.50
*12	11.00	14.80	13.10	12.50	*27	26.00	29.80	28.10	27.50
*13	12.00	15.80	14.10	13.50	*28	27.00	30.80	29.10	28.50
*14	13.00	16.80	15.10	14.50	*29	28.00	31.80	30.10	29.50
*15	14.00	17.80	16.10	15.50	*30	29.00	32.80	31.10	30.50
*16	15.00	18.80	17.10	16.50					



深圳市华德共创科技有限公司

Shenzhen Huade co-create Technology Co., LTD

TEL : 0755-27111225 FAX : 0755-29940187

-TOLERANCES- UNLESS OTHERWISE SPECIFIED 公差参数表						TITLE: 产品名称: SHLP1.0卧贴			
X.X	±0.30	X.X°	±3°	APPD: 核准:	谢亮	PART NO: 产品编号: HDGC1006WR-S-XP			
X.XX	±0.30	X.XX°	±2°	CHECK: 校对:	王建业	DATE	SCALE	UNIT	CODE NUMBER
X.XXX	±0.10	X.XXX°	±1°	DRAW: 绘图:	黄艳兰	2021-05-09	1:1	mm	A018