

产品承认书

SPECIFICATION FOR APPROVED

版本: REV.A1

客户

1186

Customer

:

客户料号

130035155 R_ 工字1216_立

Customer P/N

:

_143.5T_0.35_103K_0.9A_短

品名

工字电感

Description

:

RADIAL TYPE CHOKE INDUCTOR

产品型号

CKPK1216-1mH/K-U3.3

CENKER P/N

:

图纸编号

SP-CK112-00035298

Drawing No.

:

产品编号

Product code.

:

出图

DRAWING

制表

审核

批准

Prepared By

Checked By

Approved By

刘晓煌

梁贵传

万芳中

DATE:

2018/2/7

承认

CUSTOMER APPROVAL

DATE:



深圳市岑科实业有限公司

SHENZHEN CENKER ENTERPRISE LTD.

地址:深圳市宝安区龙华镇清泉路金博龙工业园C栋

Address: Building No.C Jinbolong Industrial
Estate, Qingquan Road, Longhua Town Shenzhen
P.R.China

TEL:0755-89808755 FAX:0755-27525256

SPECIFICATION FOR APPROVAL

RoHS COMPLIANT

客户 CUSTOMER	1186	客户料号 CUSTOMER No.	130035155 R_工字1216_立_143.5T_0.35_103K_0.9A_短	页次 PAGE
岑科料号 CENKER P/N	CKPK1216-1mH/K-U3.3	图纸编号 DRAWING No.	SP-CK112-00035298	1/6
日期 ISSUE DATE	2018/2/7	版本 VERSION	A1	

1、 DIMENSION (mm):

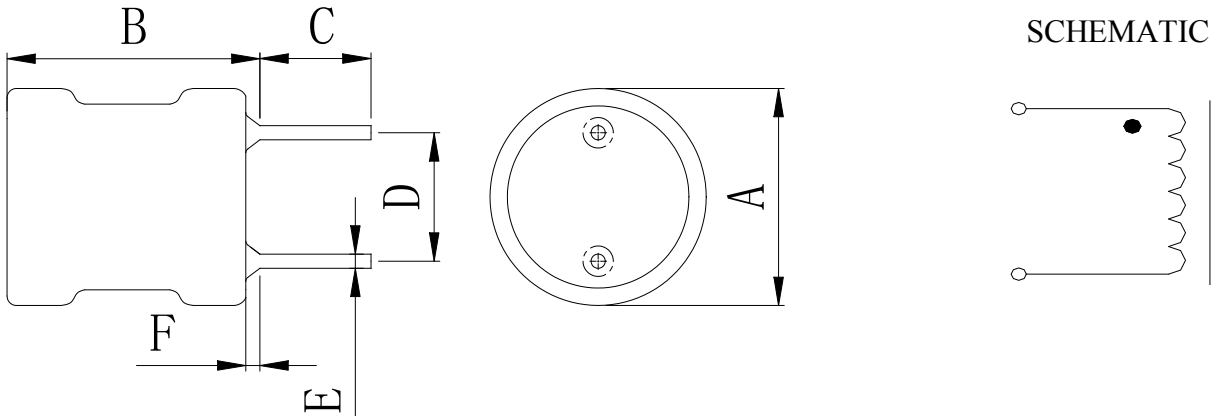

A	B	C	D	E	F
Φ 15.0 Max	20.0 Max	3.3±0.4	7.5±0.5	Φ 0.8±0.1	2.0 Max

CKPK 1216 - 1mH K - U 3.3

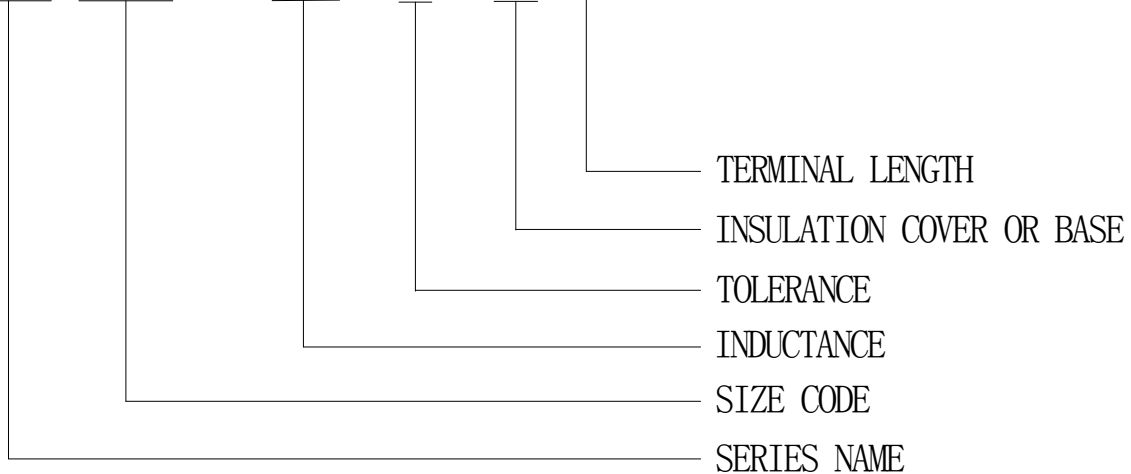

2、 TEMPERATURE RATING:

Operating Temperature : -25℃ ~ +85℃ ; Storage Temperature : -25℃ ~ +85℃

 <p>深圳市岑科实业有限公司 SHEN ZHEN CENKER ENTERPRISE LTD. TEL:0755-89808755 FAX:0755-27525256</p>	PREPARED	CHECKED	APPROVED
	刘晓煌	梁贵传	万芳中

SPECIFICATION FOR APPROVAL

RoHS COMPLIANT

客户 CUSTOMER	1186	客户料号 CUSTOMER No.	130035155 R_工字1216_立_143.5T_0.35_103K_0.9A_短	PAGE
岑科料号 CENKER P/N	CKPK1216-1mH/K-U3.3	图纸编号 DRAWING No.	SP-CK112-00035298	2/6
日期 ISSUE DATE	2018/2/7	版本 VERSION	A1	

3、ELECTRICAL REQUIREMENTS:

部品 ITEM	规格 SPEC.	公差 TOLERANCE	测试频率TEST FREQUENCY	测试仪器TEST EQUIPMENT
电感值 INDUCTANCE	1mH	±10%	1kHz/0.25V	HP-4284A
直流电阻 DCR	1Ω	Max.	at 25℃	Keysight34420A
电流 IDC	0.9A	L0A×90% Min	1kHz/0.25V	HP-4284A+HP-42841A
Q值 Q	30	Min	100kHz /0.25V	HP-4284A

4、MATERIAL LIST:

No.	原材料Material	规格 Specification	供应商 Supplier	备注 Remark
1	Core	SR60 DR 12*16	东晨	
2	Wire	Φ0.35mm*143.5±5Ts (2UEW)	深港	130℃
3	Solder	Sn99.3-Cu0.7	昌升	
4	Tube	UL Φ 12×19mm(BLACK)	沃尔	
		UL Φ 12×19mm(BLACK)	星启	
5	Epoxy	J-600	岑科	
6	Pin	CP Φ0.8×17.5mm	百川	



深圳市岑科实业有限公司
SHEN ZHEN CENKER ENTERPRISE LTD.
TEL:0755-89808755 FAX:0755-27525256

PREPARED	CHECKED	APPROVED
刘晓煌	梁贵传	万芳中

SPECIFICATION FOR APPROVAL

RoHS COMPLIANT

客户 CUSTOMER	1186		LOT No.			
客户料号 CUSTOMER No.	130035155 R_工字1216_立_143.5T_0.35_103K_0.9A_短		QUANTITY	10PCS	DATE	2018/2/7
图纸编号 DRAWING No.	SP-CK112-00035298		DIMENSION(UNIT: mm)			
零件料号 CENKER P/N	CKPK1216-1mH/K-U3.3					
部品 DESCRIPTION	工字电感 RADIAL TYPE CHOKE INDUCTOR					
测试条件 TEST FREQ	1kHz/0.25V, 100kHz/0.25V					
温度 TEMPERATURE	25 °C	湿度HUMIDITY				

5、测试数据 DATA: TESTING

电器参数 ELECTRONICAL TEST DATA					尺寸 OREALL DIMENSTON (UNIT: mm)									
	L	DCR	IDC 0.9A	Q	A	B	C	D	E	F				
SPEC	1mH ±10%	1Ω Max.	L0A×90 % Min	30 Min	Φ15.0 Max	20.0 Max	3.3±0.4	7.5±0.5	Φ 0.8±0.1	2.0 Max				
1	1.00	0.76	0.95	53	12.60	18.11	3.42	7.42	0.78	1.62				
2	0.99	0.77	0.94	52	12.65	18.05	3.33	7.40	0.78	1.58				
3	1.00	0.77	0.95	50	12.62	17.92	3.36	7.46	0.79	1.66				
4	1.00	0.76	0.95	53	12.66	18.00	3.32	7.42	0.78	1.72				
5	1.00	0.77	0.95	52	12.61	17.92	3.33	7.41	0.78	1.68				
6	1.01	0.75	0.96	50	12.64	17.89	3.38	7.48	0.79	1.53				
7	1.00	0.76	0.95	51	12.63	18.06	3.42	7.40	0.78	1.73				
8	0.99	0.76	0.94	49	12.60	18.10	3.41	7.43	0.77	1.66				
9	1.01	0.75	0.96	50	12.59	17.95	3.35	7.41	0.78	1.59				
10	1.00	0.77	0.95	51	12.64	17.93	3.36	7.38	0.80	1.74				
\bar{X}	1.00	0.76	0.95	51.10	12.62	17.99	3.37	7.42	0.78	1.65				
R	0.02	0.02	0.02	4.00	0.07	0.22	0.10	0.10	0.03	0.21				

TEST EQUIPMENT: ALL JUDGE OK NG

L CH-1062A HP-4284A
 Q HM2801A HM9481 HP-4284A
 DCR Keysight34420A
 SRF HM9460
 IDC HP-4284A+HP-42841A HM-2713-1+HM-2791 LCR

<p>深圳市岑科实业有限公司 SHEN ZHEN CENKER ENTERPRISE LTD. TEL:0755-89808755 FAX:0755-27525256</p>	PREPARED	CHECKED	APPROVED
	刘晓煌	梁贵传	万芳中

SPECIFICATION FOR APPROVAL

RoHS COMPLIANT

客户 CUSTOMER	1186	客户料号 CUSTOMER No.	130035155 R_工字1216_立_143.5T_0.35_103K_0.9A_短	页次 PAGE
岑科料号 CENKER P/N	CKPK1216-1mH/K-U3.3	图纸编号 DRAWING No.	SP-CK112-00035298	4/6
日期 ISSUE DATE	2018/2/7	版本 VERSION	A1	

6、包装PACKING(mm):

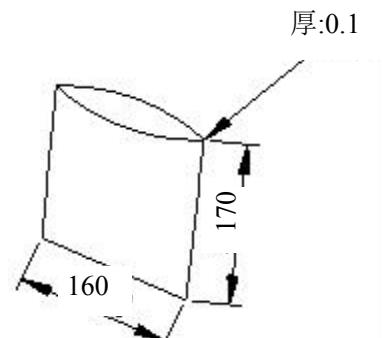
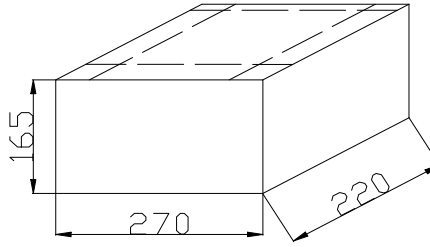
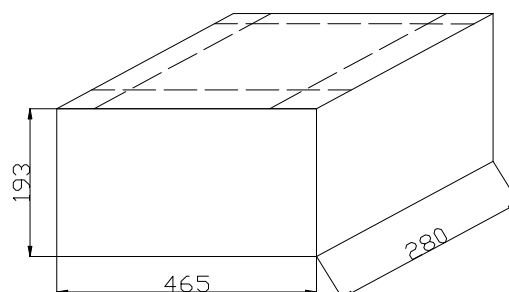
<p>1. PE袋尺寸: 160*170*0.1mm (100PCS/袋);</p>	<p>厚:0.1</p> 
<p>2. 内箱尺寸: 270*220*165mm (装10PE袋, 数量1KPCS) 材质A3A;</p>	
<p>3. 外箱尺寸: 465*280*193mm (装2个 内箱,数量为2K/PCS) 材质A+1+A;</p>	



深圳市岑科实业有限公司

SHEN ZHEN CENKER ENTERPRISE.LTD

TEL:0755-89808755 FAX:0755-27525256

PREPARED

CHECKED

APPROVED

刘晓煌

梁贵传

万芳中

SPECIFICATION FOR APPROVAL

RoHS COMPLIANT

客户 CUSTOMER	1186	客户料号 CUSTOMER No.	130035155 R_工字1216_立_143.5T_0.35_103K_0.9A_短	PAGE
岑科料号 CENKER P/N	CKPK1216-1mH/K-U3.3	图纸编号 DRAWING No.	SP-CK112-00035298	5/6
日期 DATE	2018/2/7	版本 VERSION	A1	

电感值VS直流电流 INDUCTANCE (mH) VS DC BIAS (A) CURVE

DC BIAS (A)	25°C L(mH)		100°C L(mH)			
0.00 A	1.01		1.02			
0.50 A	1.00		1.00			
0.80 A	0.98	97.0%	0.98	96.1%		
1.00 A	0.95	94.1%	0.90	88.2%		
1.20 A	0.88	87.1%	0.75	73.5%		
1.40 A	0.80	79.2%	0.51	50.0%		
1.50 A	0.72	71.3%	0.41	40.2%		
1.60 A	0.64	63.4%	0.33	32.4%		
1.70 A	0.55	54.5%	0.28	27.5%		
1.80 A	0.47		0.24			

TESTING CONDITION: 1kHz ,0.25Vrms

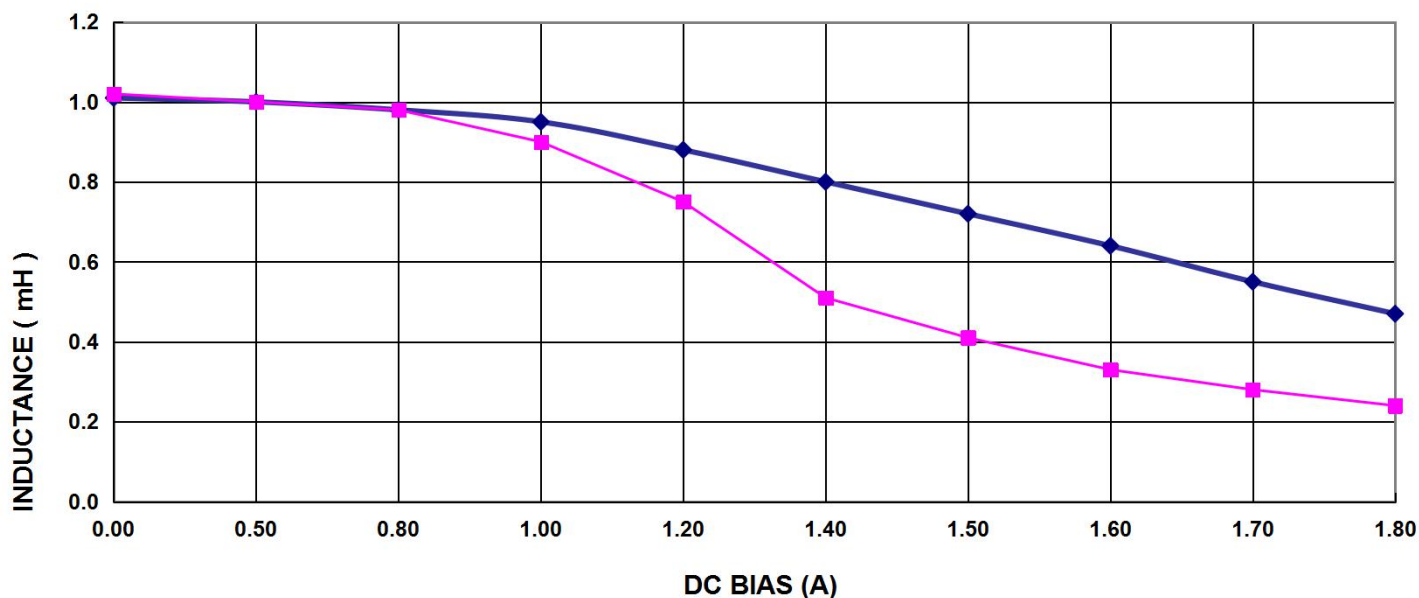

深圳市岑科实业有限公司

SHEN ZHEN CENKER ENTERPRISE LTD.

TEL:0755-89808755 FAX:0755-27525256

PREPARED

刘晓煌

CHECKED

梁贵传

APPROVED

万芳中

SPECIFICATION FOR APPROVAL

RoHS COMPLIANT

客户 CUSTOMER	1186	客户料号 CUSTOMER No.	130035155 R_工字1216_立_143.5T_0.35_103K_0.9A_短	PAGE
岑科料号 CENKER P/N	CKPK1216-1mH/K-U3.3	图纸编号 DRAWING No.	SP-CK112-00035298	6/6
日期ISSUE DATE	2018/2/7	版本 VERSION	A1	

磁芯尺寸图Magnetic core size chart

外型尺寸

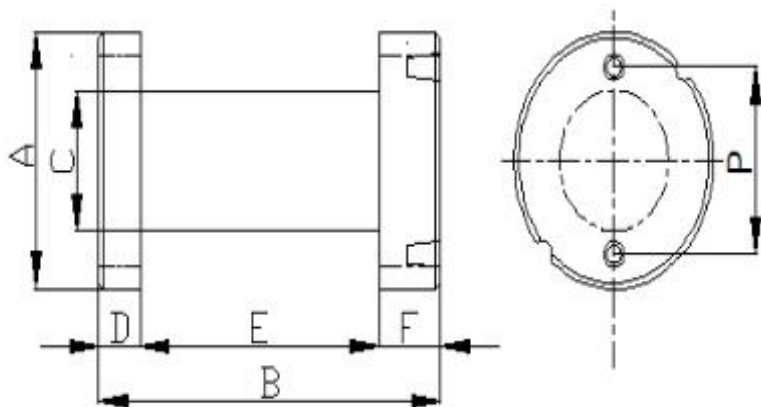

A	12.0
B	16.0
C	7.00
D	3.00
E	10.0
F	3.00
P	7.50



深圳市岑科实业有限公司
SHEN ZHEN CENKER ENTERPRISE LTD.
TEL:0755-89808755 FAX:0755-27525256

PREPARED

刘晓煌

CHECKED

梁贵传

APPROVED

万芳中