

# 产品承认书

## SPECIFICATION FOR APPROVED

版本: REV.A0

客户 : 1917  
 Customer : \_\_\_\_\_  
 客户料号 : \_\_\_\_\_  
 Customer P/N : \_\_\_\_\_  
 品名 : RADIAL TYPE CHOKE INDUCTOR  
 Description : \_\_\_\_\_  
 产品型号 : CKPK0608-33uH/K-U3.5  
 CENKER P/N : \_\_\_\_\_  
 图纸编号 : SP-CK112-GXA01414  
 Drawing No. : \_\_\_\_\_  
 产品编号 : \_\_\_\_\_  
 Product code. : \_\_\_\_\_

出图 DRAWING		
制表 Prepared By	审核 Checked By	批准 Approved By
覃玉云	张华萍	梁贵传
DATE: 2017/8/8		

承认 CUSTOMER APPROVAL
DATE:

### 深圳市岑科实业有限公司

SHENZHEN CENKER ENTERPRISE LTD.

地址:深圳市龙华区清泉路金博龙工业园C栋

Address:Building No.C Jinbolong Industrial Estate,Qingquan Road,Longhua District, Shenzhen P.R.China

TEL:0755-89808755 FAX:0755-27525256





# SPECIFICATION FOR APPROVAL

**RoHS COMPLIANT**

CUSTOMER	1917	CUSTOMER No.		PAGE
CENKER P/N	CKPK0608-33uH/K-U3.5	DRAWING No.	SP-CK112-GXA01414	1/4
ISSUE DATE	2017/8/8	VERSION	A0	

## 1、 DIMENSION (mm):

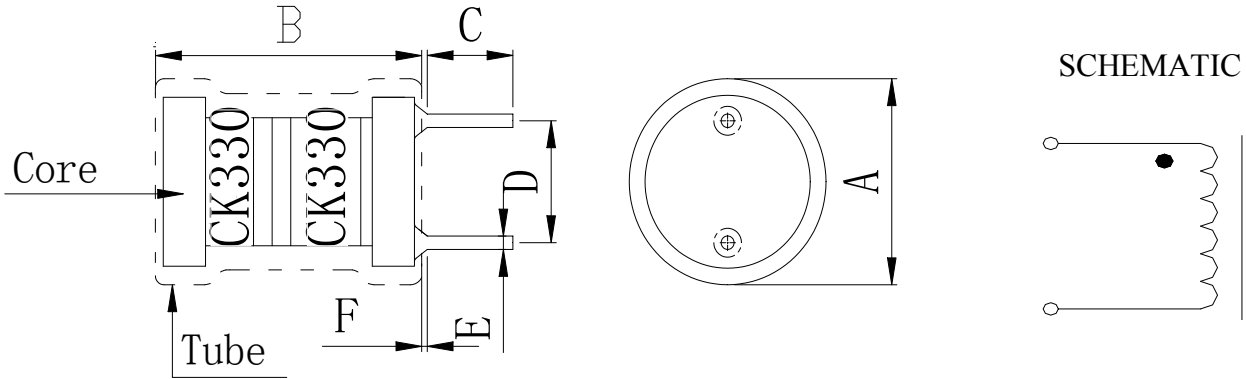

A	B	C	D	E	F
8.0 Max	11.0Max	3.5±0.5	3.0±0.5	0.6±0.05	2.0Max

CKPK 0608 - 33uH K - U 3.5

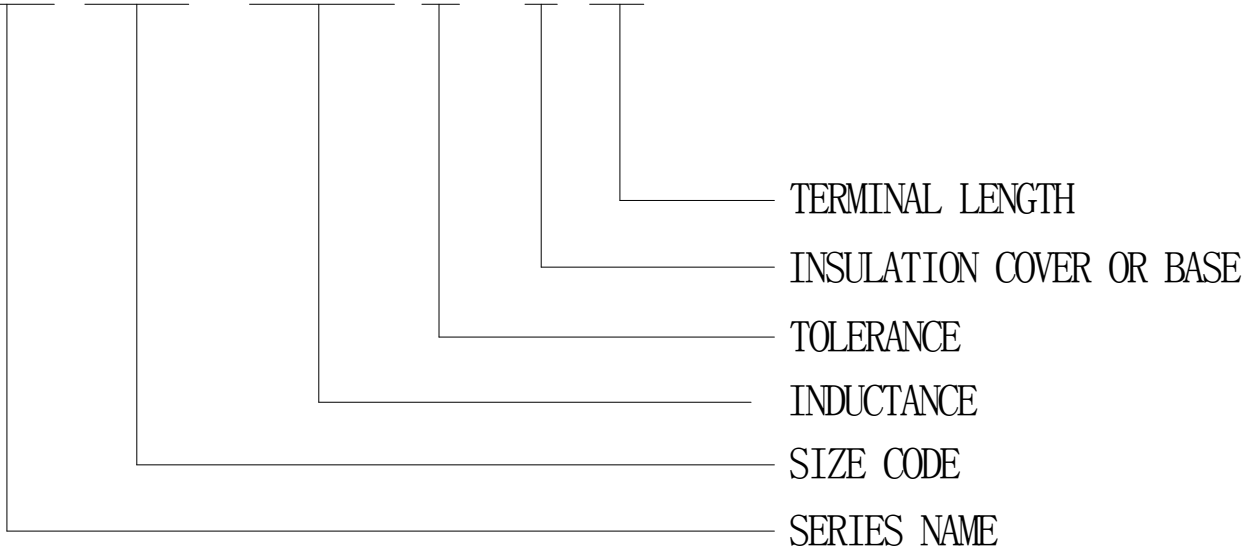

## 2、 TEMPERATURE RATING:

Operating Temperature : -25°C ~ +85°C ; Storage Temperature : -25°C ~ +85°C

 <p>深圳市岑科实业有限公司 SHEN ZHEN CENKER ENTERPRISE LTD. TEL:0755-89808755 FAX:0755-27525256</p>	PREPARED	CHECKED	APPROVED
	覃玉云	张华萍	梁贵传

**SPECIFICATION FOR APPROVAL****RoHS COMPLIANT**

CUSTOMER	1917	CUSTOMER No.		PAGE
CENKER P/N	CKPK0608-33uH/K-U3.5	DRAWING No.	SP-CK112-GXA01414	2/4
ISSUE DATE	2017/8/8	VERSION	A0	

**3、 ELECTRICAL REQUIREMENTS:**

ITEM	SPEC.	TOLERANCE	TEST FREQUENCY	TEST EQUIPMENT
INDUCTANCE	33uH	±10%	1KHz/0.25V	HP-4284A
DCR	110mΩ	Max.	at 25℃	Keysight 34420A
IDC	1A	L0A×90% Ref.	1KHz/0.25V	HP-4284A+HP-42841A

**4、 MATERIAL LIST:**

No.	Material	Specification	Supplier	Remark
1	Core	DR6×8or equivalent	SUNRISE FERRITE CORES ELECTRONIC CO.,LTD.	
2	Wire	Ø0.35mm×35.5Ts (2UEW) or equivalent	SHANTOU SHENGANG ELECTRICAL INDUSTRIAL CO., LTD.	130℃
3	Solder	Sn99.3-Cu0.7 or equivalent	HuiZhou Chang Sheng METAL PRODUCTS CO.,LTD	
4	Tube	UL Φ6×10.5mm (BLACK) or equivalent	SHENZHEN WOER HEAT-SHRINKABLE MATERIAL CO.,LTD	
		UL Φ6×10.5mm (BLACK) or equivalent	SHENZHEN XINGQI PLASTIC PRO DUCTS CO.,LTD.	
5	Epoxy	J-600 or equivalent	SHEN ZHEN CENKER ENTERPRISE LTD.	
6	Pin	CP Φ0.6*17.5mm or equivalent	JIANGXI BAICHUAN ELECTRIC CONDUCTOR CO.,LTD	



深圳市岑科实业有限公司  
 SHEN ZHEN CENKER ENTERPRISE LTD.  
 TEL:0755-89808755 FAX:0755-27525256

PREPARED	CHECKED	APPROVED
覃玉云	张华萍	梁贵传

# SPECIFICATION FOR APPROVAL

**RoHS COMPLIANT**

PAGE:3/4

CUSTOMER	1917	LOT No.			
CUSTOMER No.		QUANTITY	10PCS	DATE	2017/8/8
DRAWING No.	SP-CK112-GXA01414	DIMENSION(UNIT: mm)			
CENKER P/N	CKPK0608-33uH/K-U3.5				
DESCRIPTION	RADIAL TYPE CHOKE INDUCTOR				
TEST FREQ	1KHz/0.25V				
TEMPERATURE	25 °C				

## 5. TESTING DATA:

ELECTRONICAL TEST DATA				OREALL DIMENSTON (UNIT: mm)									
	L	IDC 1A	DCR	A	B	C	D	E	F				
SPEC	33uH ±10%	L0A×90% Ref.	110mΩ MAX	8.0 Max	11.0Max	3.5±0.5	3.0±0.5	0.6±0.05	2.0Max				
1	32.70	31.29	81.75	6.62	10.05	3.55	3.07	0.59	1.42				
2	32.50	31.01	81.36	6.63	10.09	3.56	3.05	0.58	1.42				
3	33.20	31.57	81.03	6.59	10.05	3.58	3.06	0.58	1.40				
4	32.50	30.97	81.48	6.64	10.07	3.59	3.05	0.57	1.46				
5	32.70	31.07	81.73	6.60	10.06	3.59	3.09	0.59	1.45				
6	32.90	31.55	81.56	6.59	10.03	3.57	3.08	0.59	1.43				
7	33.00	31.42	81.24	6.65	10.02	3.55	3.06	0.58	1.43				
8	33.30	31.67	81.69	6.62	10.07	3.55	3.04	0.57	1.44				
9	32.50	30.97	81.37	6.64	10.07	3.52	3.06	0.58	1.45				
10	32.70	31.20	81.64	6.61	10.01	3.55	3.08	0.59	1.46				
$\bar{X}$	32.80	31.27	81.49	6.62	10.05	3.56	3.06	0.58	1.44				
R	0.80	0.70	0.72	0.06	0.08	0.07	0.05	0.02	0.06				

**TEST EQUIPMENT:** ALL JUDGE  OK  NG

L CH-1062A HP-4284A  
 Q HM2801A HM9481 CJ2851  
 DCR Keysight 34420A  
 SRF HM9460  
 IDC HP-4284A+HP-42841A HM-2713-1+HM-2791 LCR

<p>深圳市岑科实业有限公司 SHEN ZHEN CENKER ENTERPRISE LTD. TEL:0755-89808755 FAX:0755-27525256</p>	PREPARED	CHECKED	APPROVED
	覃玉云	张华萍	梁贵传

# SPECIFICATION FOR APPROVAL

**RoHS COMPLIANT**

CUSTOMER	1917	CUSTOMER No.		PAGE
CENKER P/N	CKPK0608-33uH/K-U3.5	DRAWING No.	SP-CK112-GXA01414	4/4
ISSUE DATE	2017/8/8	VERSION	A0	

## 6、PACKING(mm):

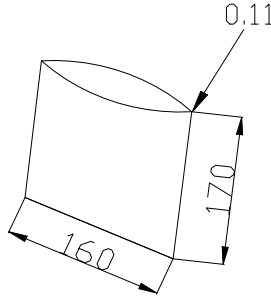
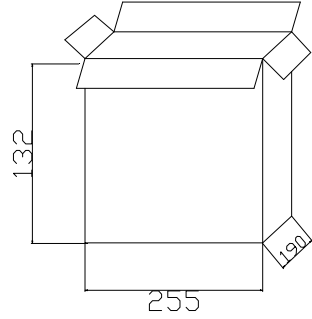
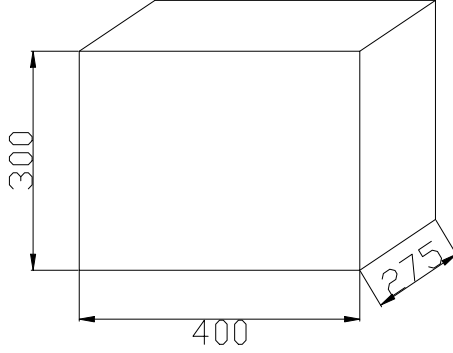
<p>1. PE BAG: 160*170*0.11mm ( 500 PCS/BAG );</p>	
<p>2. Inside the box size: 255*190*132mm ( Loading 10PE BAG ,Quantity5K/PCS )</p>	
<p>3. Outer box: 400*275*300mm ( Loading4 inner box , Quantity 20K/PCS )</p>	



深圳市岑科实业有限公司  
SHEN ZHEN CENKER ENTERPRISE LTD.  
TEL:0755-89808755 FAX:0755-27525256

PREPARED	CHECKED	APPROVED
覃玉云	张华萍	梁贵传