

产品承认书

SPECIFICATION FOR APPROVED

版本: REV.A1

客户 : 1518
 Customer : _____
 客户料号 : _____
 Customer P/N : _____
 品名 : RADIAL TYPE CHOKE INDUCTOR
 Description : _____
 产品型号 : CKPK0608-100uH/K-U3
 CENKER P/N : _____
 图纸编号 : SP-CK112-GXA01464
 Drawing No. : _____
 产品编号 : _____
 Product code. : _____

出图 DRAWING		
制表 Prepared By	审核 Checked By	批准 Approved By
覃玉云	张华萍	梁贵传
DATE: 2017/9/9		

承认 CUSTOMER APPROVAL
DATE:

深圳市岑科实业有限公司

SHENZHEN CENKER ENTERPRISE LTD.

地址:深圳市龙华区清泉路金博龙工业园C栋

Address:Building No.C Jinbolong Industrial Estate,Qingquan Road,Longhua District, Shenzhen P.R.China

TEL:0755-89808755 FAX:0755-27525256



SPECIFICATION FOR APPROVAL

RoHS COMPLIANT

CUSTOMER	1518	CUSTOMER No.		PAGE
CENKER P/N	CKPK0608-100uH/K-U3	DRAWING No.	SP-CK112-GXA01464	1/6
ISSUE DATE	2017/9/9	VERSION	A1	

1、 DIMENSION (mm):

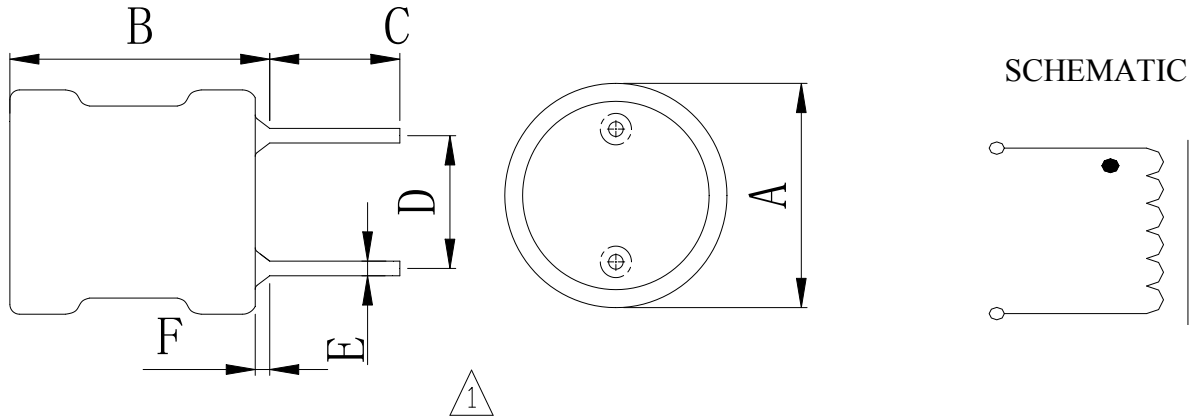

A	B	C	D	E	F
8.0 Max	11.0Max	3.0±0.5	3.0±0.5	0.6±0.05	2.0Max

CKPK 0608 - 100uH K - U 3

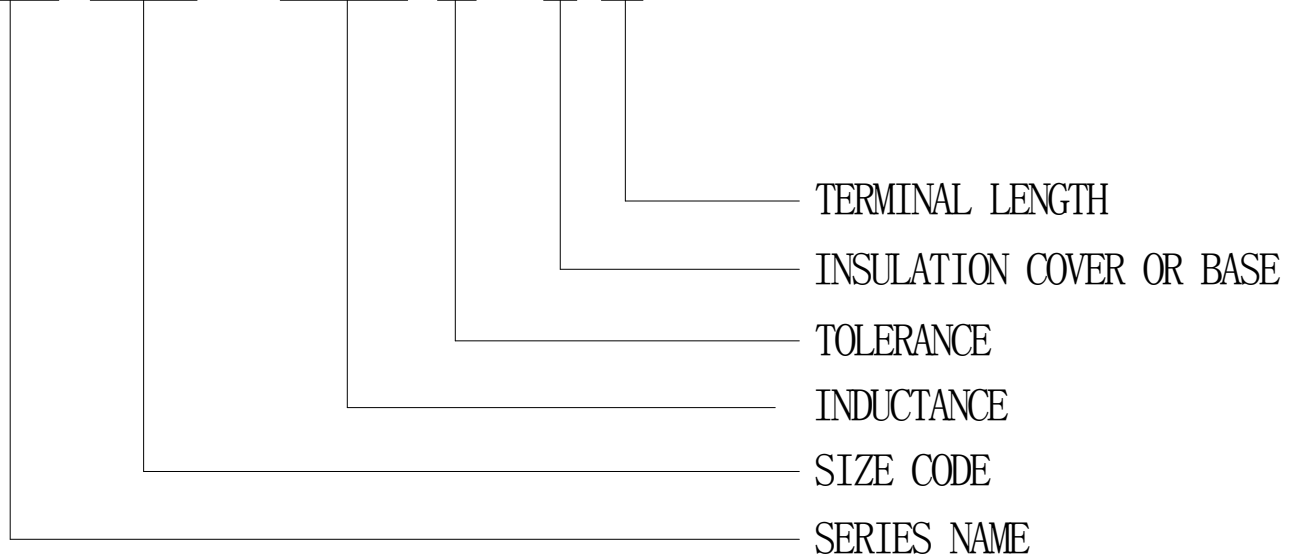

2、 TEMPERATURE RATING:

Operating Temperature : -25℃ ~ +85℃ ; Storage Temperature : -25℃ ~ +85℃

Storage Humidity:30%-75% storage time : one year

 <p>深圳市岑科实业有限公司 SHEN ZHEN CENKER ENTERPRISE LTD. TEL:0755-89808755 FAX:0755-27525256</p>	PREPARED	CHECKED	APPROVED
	覃玉云	张华萍	梁贵传

SPECIFICATION FOR APPROVAL

RoHS COMPLIANT

CUSTOMER	1518	CUSTOMER No.		PAGE
CENKER P/N	CKPK0608-100uH/K-U3	DRAWING No.	SP-CK112-GXA01464	2/6
ISSUE DATE	2017/9/9	VERSION	A1	

3、 ELECTRICAL REQUIREMENTS:

ITEM	SPEC.	TOLERANCE	TEST FREQUENCY	TEST EQUIPMENT
INDUCTANCE	100uH	±10%	1KHz/0.25V	HP-4284A
DCR	0.35Ω	Max.	at 25°C	Keysight34420A
IDC	0.5A	L0A×90% Ref.	1KHz/0.25V	HP-4284A+HP-42841A

4、 MATERIAL LIST:

No.	Material	Specification	Supplier	UL.NO.
1	Core	DR6×8 or equivalent	东晨	
2	Wire	Ø0.28mm×61.5Ts. Ref. (2UEW/130) or equivalent	深港	E239508
3	Solder	Sn99.3-Cu0.7 or equivalent	昌升	
4	Tube	UL Φ6*10.5mm (BLACK-125°C) RSFR-H	沃尔	E203950
		UL Φ6*10.5mm(BLACK-125°C) X-2	星启	E350991
5	Epoxy	J-600 or equivalent	岑科	
6	Pin	CP Φ0.6×17.5mm or equivalent	百川	

Tube Marking :

- 1.Custnmer have asked sense of identity , marking inductance such as “CK102”;
2. Normally not Marking inductance request ,Mark content for supplier information such as “Size,UL.NO,Temperature,voltage range ”



深圳市岑科实业有限公司
 SHEN ZHEN CENKER ENTERPRISE LTD.
 TEL:0755-89808755 FAX:0755-27525256

PREPARED	CHECKED	APPROVED
覃玉云	张华萍	梁贵传

SPECIFICATION FOR APPROVAL

RoHS COMPLIANT

PAGE:3/6

CUSTOMER	1518	LOT No.			
CUSTOMER No.		QUANTITY	10PCS	DATE	2017/9/9
DRAWING No.	SP-CK112-GXA01464	DIMENSION(UNIT: mm)			
CENKER P/N	CKPK0608-100uH/K-U3				
DESCRIPTION	RADIAL TYPE CHOKE INDUCTOR				
TEST FREQ	1KHz/0.25V				
TEMPERATURE	25 °C				

5. TESTING DATA:

ELECTRONICAL TEST DATA				OREALL DIMENSTON (UNIT: mm)									
	L	IDC 0.5A	DCR	A	B	C	D	E	F				
SPEC	100uH ±10%	L0A×90 % Ref.	0.35Ω Max.	8.0 Max	11.0Max	3.0±0.5	3.0±0.5	0.6±0.05	2.0Max				
1	98.30	93.58	0.23	6.61	9.64	3.08	2.97	0.58	1.46				
2	97.60	93.01	0.24	6.59	9.71	3.12	3.03	0.59	1.52				
3	97.80	93.11	0.23	6.57	9.71	3.15	2.99	0.57	1.53				
4	98.20	93.29	0.23	6.59	9.72	3.16	2.99	0.59	1.47				
5	97.20	92.44	0.23	6.57	9.67	3.11	3.05	0.58	1.55				
6	98.10	93.39	0.24	6.63	9.72	3.14	3.01	0.58	1.55				
7	97.90	93.30	0.24	6.60	9.68	3.09	2.99	0.57	1.48				
8	97.60	92.72	0.23	6.57	9.69	3.13	2.96	0.59	1.47				
9	98.00	93.20	0.24	6.60	9.66	3.08	3.02	0.57	1.51				
10	97.40	92.92	0.24	6.61	9.63	3.17	2.97	0.59	1.52				
\bar{X}	97.81	93.10	0.24	6.59	9.68	3.12	3.00	0.58	1.50				
R	1.10	1.14	0.01	0.06	0.08	0.09	0.08	0.02	0.09				

TEST EQUIPMENT: ALL JUDGE OK NG

L CH-1062A HP-4284A
 Q HM2801A HM9481 CJ2851
 DCR Keysight34420A
 SRF HM9460
 IDC HP-4284A+HP-42841A HM-2791&HM-2713

<p>深圳市岑科实业有限公司 SHEN ZHEN CENKER ENTERPRISE LTD. TEL:0755-89808755 FAX:0755-27525256</p>	PREPARED	CHECKED	APPROVED
	覃玉云	张华萍	梁贵传

SPECIFICATION FOR APPROVAL

RoHS COMPLIANT

CUSTOMER	1518	CUSTOMER No.		PAGE 4/6
CENKER P/N	CKPK0608-100uH/K-U3	DRAWING No.	SP-CK112-GXA01464	
ISSUE DATE	2017/9/9	VERSION	A1	

6、PACKING(mm):

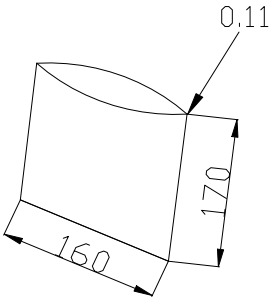
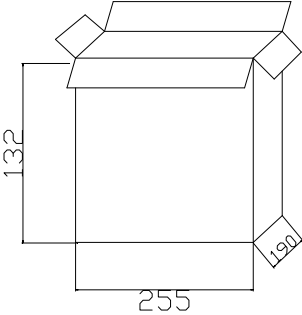
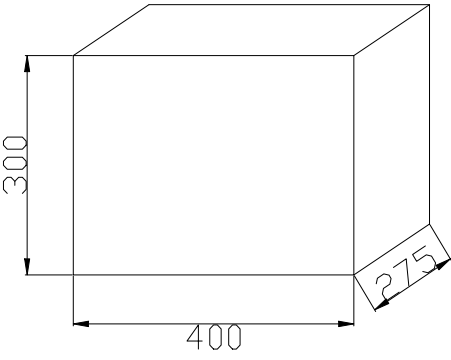
<p>1. PE BAG: 160*170*0.11mm (500PCS/BAG);</p>	
<p>2. Inside the box size: 255*190*132mm (Loading 10PE BAG ,Quantity 5K/PCS)</p>	
<p>3. Outer box: 400*275*300mm (Loading 4 inner box , Quantity 20K/PCS)</p>	



深圳市岑科实业有限公司

SHEN ZHEN CENKER ENTERPRISE LTD.

TEL:0755-89808755 FAX:0755-27525256

PREPARED

覃玉云

CHECKED

张华萍

APPROVED

梁贵传

SPECIFICATION FOR APPROVAL

RoHS COMPLIANT

CUSTOMER	1518	CUSTOMER No.		PAGE
CENKER P/N	CKPK0608-100uH/K-U3	DRAWING No.	SP-CK112-GXA01464	5/6
ISSUE DATE	2017/9/9	VERSION	A1	

7、RELIABILITY TEST

NO.	ITEM	REQUEST	CONDITIONS	RESULT
1	Solderability	Solder shall be attached uniformly around the dipped portion over 90%.	Dipping into solder at 245±5℃ for 3±0.5s.	OK
2	Solder Heat Resistance	Appearance and structure shall be no abnormality;parameters meet the characteristics.	Dipping into solder at 260±5℃ for 10±1s up to 1 to 1.5mm from the attachment surface.	OK
3	High temperature test	Appearance 、 structure、 and electrical characteristics shall not be remarkably changed after festing	Temperature: +85℃ Time: 96 hours Room condition: 1~2 hours	OK
4	Low temperature test	Appearance 、 structure、 and electrical characteristics shall not be remarkably changed after festing	Temperature: -25℃ Time: 96 hours Room condition: 1~2 hours	OK
5	Temperature Cycle	Appearance 、 structure、 and electrical characteristics shall not be remarkably changed after festing	(-25℃/1h-Normal Temp .1h +85℃/1h→Normal Temp /1h 10 Cycles .After test ,keeping in normal environment 1~2h)	OK
6	Humidity Test	Appearance 、 structure、 and electrical characteristics shall not be remarkably changed after festing	Stored for 96 hours at 40±2℃ , RH90~95%,And left for 1~2 hours in room conditions	OK
7	Thermal Shock	Appearance 、 structure、 and electrical characteristics shall not be remarkably changed after festing	(-25±2℃ 30min~room ambient 10min,+85±2℃ 30min ~room ambient10min 10 cycles ,left for 1~2 hours in room conditions .)	OK



深圳市岑科实业有限公司
 SHEN ZHEN CENKER ENTERPRISE.LTD
 TEL:0755-89808755 FAX:0755-27525256

PREPARED	CHECKED	APPROVED
覃玉云	张华萍	梁贵传

SPECIFICATION FOR APPROVAL

RoHS COMPLIANT

CUSTOMER	1518	CUSTOMER No.		PAGE
CENKER P/N	CKPK0608-100uH/K-U3	DRAWING No.	SP-CK112-GXA01464	6/6
ISSUE DATE	2017/9/9	VERSION	A1	

Flow (wave) soldering curve

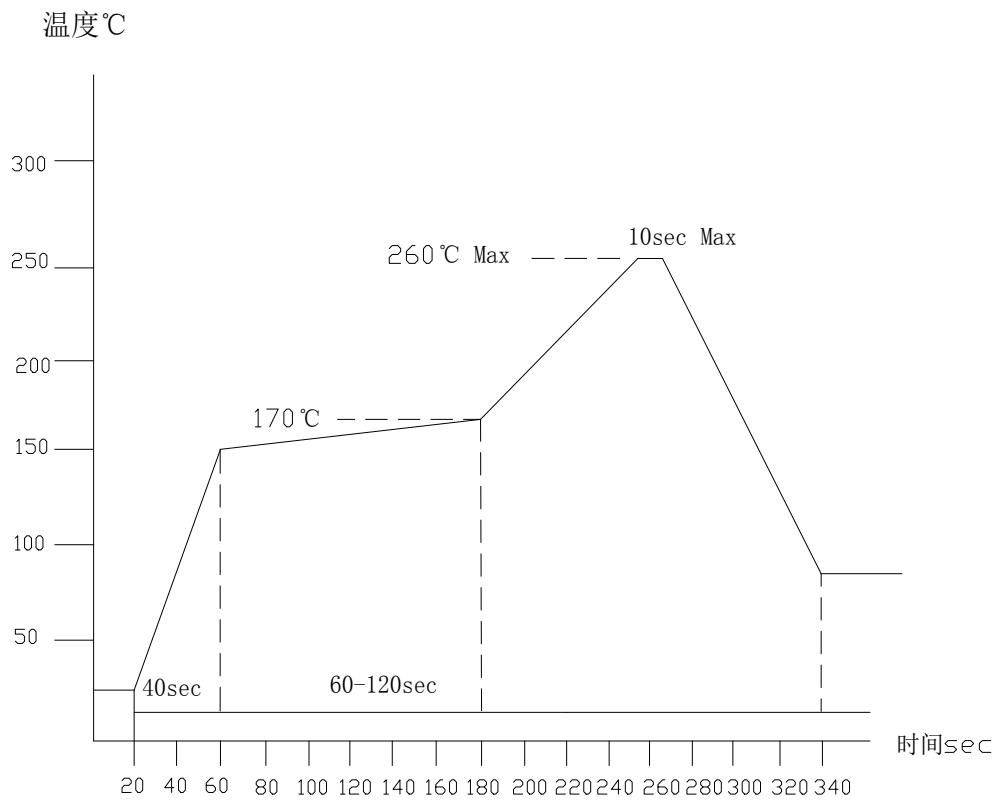

深圳市岑科实业有限公司
 SHEN ZHEN CENKER ENTERPRISE LTD.
 TEL:0755-89808755 FAX:0755-27525256

PREPARED	CHECKED	APPROVED
覃玉云	张华萍	梁贵传