

零件承认书

APPROVAL SHEET

厂商名称: 深圳市岑科实业有限公司

MANUFACTURER NAME

代理商名称:

AGENT NAME

零件名称: 工字电感

PART NAME

系列号: ALF0250-250

SERIES NO.

零件规格: CKPK0608-1.1mH/K-U5.5

SPECIFICATION

使用机种:

USED IN

承认日期: 2018-4-25

APPROVED DATE

承认印栏 APPROVED SIGNATURE				厂商盖章栏 MANUFACTURER SIGNATURE		
批准 APPROVED BY	审核 CHECKED BY	确认 AFFIRMED BY	测试 TESTED BY	批准 APPROVED BY	审核 CHECKED BY	测试 AFFIRMED BY
				梁贵传	张华萍	覃玉云

浙江榆阳电子有限公司

电话: 057389817050

TEL: 057389817050

传真: 057389817000

FAX: 057389817000

网址: WWW.LINKPOWER.NET.CN

WEB: WWW.LINKPOWER.NET.CN

地址: 浙江桐乡经济开发区同德路 656 号

ADDR: NO. 656, Tongde Road, Tongxiang, Zhejiang, China

邮编: 314500

P.C.: 314500

产品承认书

SPECIFICATION FOR APPROVED

版本: REV.A0

客户

2130

Customer

:

客户料号

ALF0250-250

Customer P/N

:

品名

RADIAL TYPE CHOKE INDUCTOR

Description

:

产品型号

CKPK0608-1.1mH/K-U5.5

CENKER P/N

:

图纸编号

SP-CK112-GXA03022

Drawing No.

:

产品编号

Product code.

:

出图

DRAWING

制表

审核

批准

Prepared By

Checked By

Approved By

覃玉云

张华萍

梁贵传

DATE:

2018/4/25

承认

CUSTOMER APPROVAL

DATE:



深圳市岑科实业有限公司

SHENZHEN CENKER ENTERPRISE LTD.

地址:深圳市龙华区清泉路金博龙工业园C栋

Address: Building No.C Jinbolong Industrial
Estate, Qingquan Road, Longhua District, Shenzhen
P.R.China

TEL:0755-89808755 FAX:0755-27525256



SPECIFICATION FOR APPROVAL

RoHS COMPLIANT

CUSTOMER	2130	CUSTOMER No.	ALF0250-250	PAGE
CENKER P/N	CKPK0608-1.1mH/K-U5.5	DRAWING No.	SP-CK112-GXA03022	1/4
ISSUE DATE	2018/4/25	VERSION	A0	

1、 DIMENSION (mm):

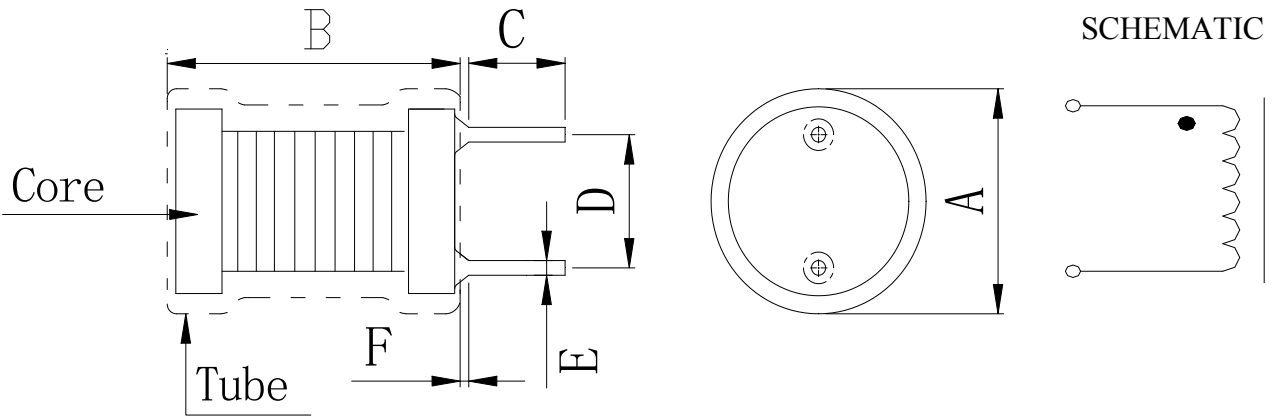

A	B	C	D	E	F
7.0Max	10.5 Max	5.5±0.5	3.0±0.5	0.6±0.05	1.5Max

CKPK 0608 - 1.1mH K - U 5.5

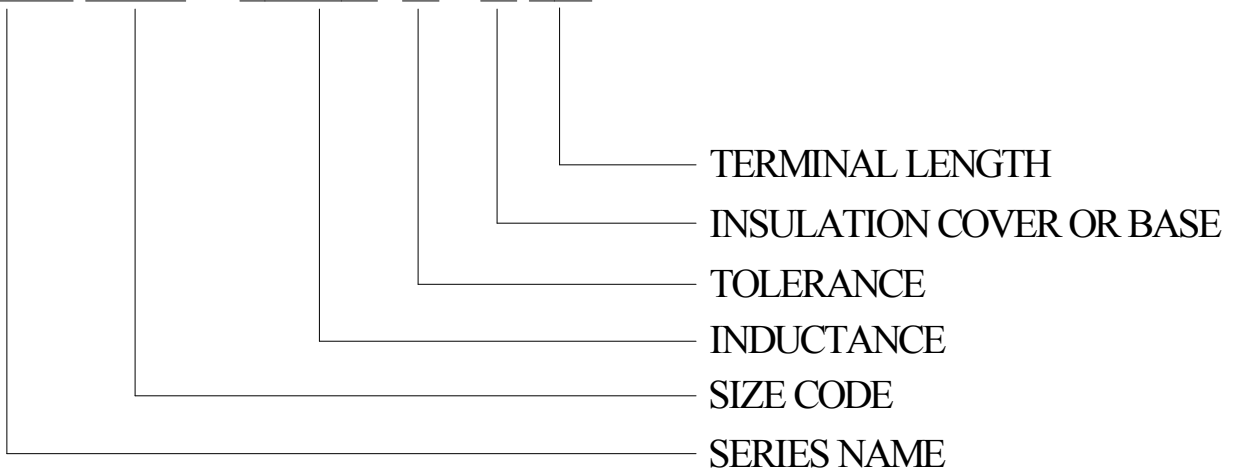

2、 TEMPERATURE RATING:

Operating Temperature : -25°C ~ +85°C ; Storage Temperature : -25°C ~ +85°C

 <p>深圳市岑科实业有限公司 SHEN ZHEN CENKER ENTERPRISE LTD. TEL:0755-89808755 FAX:0755-27525256</p>	PREPARED	CHECKED	APPROVED
	覃玉云	张华萍	梁贵传

SPECIFICATION FOR APPROVAL

RoHS COMPLIANT

CUSTOMER	2130	CUSTOMER No.	ALF0250-250	PAGE
CENKER P/N	CKPK0608-1.1mH/K-U5.5	DRAWING No.	SP-CK112-GXA03022	2/4
ISSUE DATE	2018/4/25	VERSION	A0	

3、ELECTRICAL REQUIREMENTS:

ITEM	SPEC.	TOLERANCE	TEST FREQUENCY	TEST EQUIPMENT
INDUCTANCE	1.1mH	±10%	10kHz/0.25V	HP-4284A
DCR	3Ω	Max.	at 25℃	Keysight34420A
IDC	0.2A	L0A×90% Ref.	10kHz/0.25V	HP-4284A+HP-42841A

4、MATERIAL LIST:

No.	Material	Specification	Supplier	Remark
1	Core	DR6×8 or equivalent	东晨铁氧体芯电子有限公司	
		DR6×8 or equivalent	沅陵辰州磁电高科有限公司	
2	Wire	Φ0.16mm×213.5Ts Ref (2UEW) or equivalent	汕头深港电工实业有限公司	155℃
3	Solder	Sn99.3-Cu0.7 or equivalent	惠州市昌升金属制品有限公司	
4	Tube	UL Φ 6mm(BLACK) or equivalent	深圳市沃尔核材股份有限公司	
		UL Φ 6mm(BLACK) or equivalent	深圳市星启塑胶制品有限公司	
5	Epoxy	J-600 or equivalent	深圳市岑科实业有限公司	
6	Pin	CP Φ0.6×17.5mm or equivalent	江西百川电导体有限公司	

 深圳市岑科实业有限公司 SHEN ZHEN CENKER ENTERPRISE LTD. TEL:0755-89808755 FAX:0755-27525256	PREPARED	CHECKED	APPROVED
	覃玉云	张华萍	梁贵传

SPECIFICATION FOR APPROVAL

RoHS COMPLIANT

PAGE:3/4

CUSTOMER	2130	LOT No.			
CUSTOMER No.	ALF0250-250	QUANTITY	10PCS	DATE	2018/4/25
DRAWING No.	SP-CK112-GXA03022	DIMENSION(UNIT: mm)			
CENKER P/N	CKPK0608-1.1mH/K-U5.5				
DESCRIPTION	RADIAL TYPE CHOKE INDUCTOR				
TEST FREQ	10kHz/0.25V				
TEMPERATURE	25 °C				

5. TESTING DATA:

ELECTRONICAL TEST DATA				OREALL DIMENSTON (UNIT: mm)								
	L	IDC 0.2A	DCR	A	B	C	D	E	F			
SPEC	1.1mH ±10%	L0A×90 % Ref.	3Ω Max.	7.0Max	10.5 Max	5.5±0.5	3.0±0.5	0.6±0.05	1.5Max			
1	1.13	1.07	2.54	6.60	10.02	5.57	3.04	0.59	0.92			
2	1.10	1.05	2.55	6.62	9.99	5.57	3.06	0.59	0.98			
3	1.11	1.06	2.56	6.61	10.02	5.54	3.06	0.58	0.96			
4	1.11	1.06	2.55	6.64	9.96	5.55	3.00	0.57	0.97			
5	1.10	1.04	2.54	6.61	9.97	5.57	3.04	0.58	0.91			
6	1.12	1.07	2.55	6.67	10.03	5.54	2.98	0.58	0.94			
7	1.11	1.06	2.56	6.66	9.98	5.56	3.00	0.58	0.96			
8	1.10	1.05	2.54	6.69	9.96	5.57	3.05	0.58	0.93			
9	1.13	1.08	2.55	6.67	10.01	5.58	3.06	0.58	0.93			
10	1.12	1.07	2.54	6.61	10.02	5.51	3.00	0.57	0.95			
\bar{X}	1.11	1.06	2.55	6.64	10.00	5.56	3.03	0.58	0.95			
R	0.03	0.04	0.02	0.08	0.07	0.07	0.08	0.02	0.07			

TEST EQUIPMENT:

ALL JUDGE

OK NG

L CH-1062A HP-4284A

Q HM2801A HM9481 CJ2851

DCR Keysight34420A CH-502A

SRF HM9460

IDC HP-4284A+HP-42841A



深圳市岑科实业有限公司

SHEN ZHEN CENKER ENTERPRISE LTD.

TEL:0755-89808755 FAX:0755-27525256

PREPARED

覃玉云

CHECKED

张华萍

APPROVED

梁贵传

SPECIFICATION FOR APPROVAL

RoHS COMPLIANT

CUSTOMER	2130	CUSTOMER No.	ALF0250-250	PAGE
CENKER P/N	CKPK0608-1.1mH/K-U5.5	DRAWING No.	SP-CK112-GXA03022	4/4
ISSUE DATE	2018/4/25	VERSION	A0	

6、PACKING(mm):

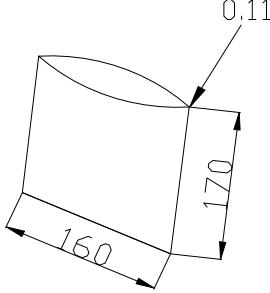
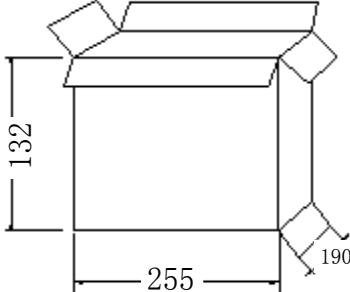
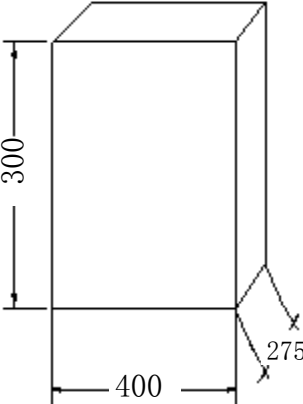
<p>1. PE BAG: 160*170*0.11mm (500PCS/BAG);</p>	
<p>2. Inside the box size: 255*190*132mm (Loading10PE BAG ,Quantity 5K/PCS)</p>	
<p>3. Outer box: 400*275*300mm (Loading4Inside the box ,Quantity 20K/PCS)</p>	



深圳市岑科实业有限公司

SHEN ZHEN CENKER ENTERPRISE.LTD

TEL:0755-89808755 FAX:0755-27525256

PREPARED

覃玉云

CHECKED

张华萍

APPROVED

梁贵传