

FEATURES

Ultrafast symmetric multiplier

$$\text{Function: } V_W = \alpha \times (V_X \times V_Y) / 1V + V_Z$$

Unique design ensures absolute XY-symmetry

Identical X and Y amplitude/timing responses

Adjustable gain scaling, α

DC-coupled throughout, 3 dB bandwidth of 2 GHz

Fully differential inputs, may be used single ended

Low noise, high linearity

Accurate, temperature stable gain scaling

Single-supply operation (4.5 V to 5.5 V at 130 mA)

Low current power-down mode

16-lead LFCSP

APPLICATIONS

Wideband multiplication and summing

High frequency analog modulation

Adaptive antennas (diversity/phased array)

Square-law detectors and true rms detectors

Accurate polynomial function synthesis

DC capable VGA with very fast control

GENERAL DESCRIPTION

The ADL5391 draws on three decades of experience in advanced analog multiplier products. It provides the same general mathematical function that has been field proven to provide an exceptional degree of versatility in function synthesis.

$$V_W = \alpha \times (V_X \times V_Y) / 1V + V_Z$$

The most significant advance in the ADL5391 is the use of a new multiplier core architecture, which differs markedly from the conventional form that has been in use since 1970. The conventional structure that employs a current mode, translinear core is fundamentally asymmetric with respect to the X and Y inputs, leading to relative amplitude and timing misalignments that are problematic at high frequencies. The new multiplier core eliminates these misalignments by offering symmetric signal paths for both X and Y inputs. The Z input allows a signal to be added directly to the output. This can be used to cancel a carrier or to apply a static offset voltage.

The fully differential X, Y, and Z input interfaces are operational over a ± 2 V range, and they can be used in single-ended fashion.

The user can apply a common mode at these inputs to vary from the internally set $V_{POS}/2$ down to ground. If these inputs

FUNCTIONAL BLOCK DIAGRAM

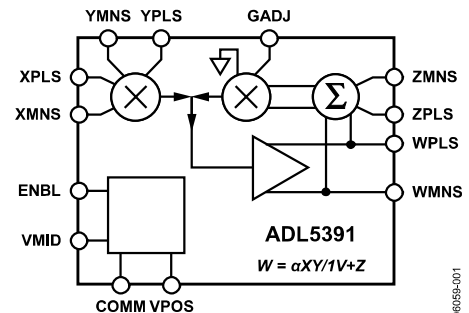

Figure 1.

are ac-coupled, their nominal voltage will be $V_{POS}/2$. These input interfaces each present a differential 500 Ω input impedance up to approximately 700 MHz, decreasing to 50 Ω at 2 GHz. The gain scaling input, GADJ, can be used for fine adjustment of the gain scaling constant (α) about unity.

The differential output can swing ± 2 V about the $V_{POS}/2$ common-mode and can be taken in a single-ended fashion as well. The output common mode is designed to interface directly to the inputs of another ADL5391. Light dc loads can be ground referenced; however, ac-coupling of the outputs is recommended for heavy loads.

The ENBL pin allows the ADL5391 to be disabled quickly to a standby mode. It operates off supply voltages from 4.5 V to 5.5 V while consuming approximately 130 mA.

The ADL5391 is fabricated on Analog Devices, Inc. proprietary, high performance, 65 GHz, SOI complementary, SiGe bipolar IC process. It is available in a 16-lead, RoHS compliant, LFCSP and operates over a -40°C to $+85^{\circ}\text{C}$ temperature range. Evaluation boards are available.

Rev. A

Document Feedback

Information furnished by Analog Devices is believed to be accurate and reliable. However, no responsibility is assumed by Analog Devices for its use, nor for any infringements of patents or other rights of third parties that may result from its use. Specifications subject to change without notice. No license is granted by implication or otherwise under any patent or patent rights of Analog Devices. Trademarks and registered trademarks are the property of their respective owners.

TABLE OF CONTENTS

Features	1	Typical Performance Characteristics	7
Applications.....	1	Theory of Operation	10
Functional Block Diagram	1	Basic Theory	10
General Description	1	Basic Connections.....	10
Revision History	2	Evaluation Board	13
Specifications.....	3	Outline Dimensions	15
Absolute Maximum Ratings.....	5	Ordering Guide	15
ESD Caution.....	5		
Pin Configuration and Function Descriptions.....	6		

REVISION HISTORY

10/2017—Rev. 0 to Rev. A

Changed CP-16-3 to CP-16-27	Throughout
Added EPAD, Table 3.....	6
Changed General Description to Theory of Operation	10
Updated Outline Dimensions	15
Changes to Ordering Guide	15

7/2006—Revision 0: Initial Version

SPECIFICATIONS

$V_{POS} = 5\text{ V}$, $T_A = 25^\circ\text{C}$, $Z_L = 50\ \Omega$ differential, ZPLS = ZMNS = open, GADJ = open, unless otherwise noted. Transfer function: $W = XY/1\text{ V} + Z$, common mode internally set to 2.5 V nominal.

Table 1.

Parameter	Conditions	Min	Typ	Max	Unit
MULTIPLICAND INPUTS (X, Y)	XPLS, XMNS, YPLS, YMNS				
Differential Voltage Range	Differential, common mode = 2.5 V		2		V p-p
Common-Mode Range	For full differential range	0		2.5	V
Input Offset Voltage	DC		20		mV
vs. Temperature	-40°C to $+85^\circ\text{C}$		± 20		mV
Differential Input Impedance	$f = \text{dc}$		500		Ω
	$f = 2\text{ GHz}$		150		Ω
Fundamental Feedthrough, X or Y	$f = 50\text{ MHz}$, X (Y) = 0 V, Y (X) = 0 dBm, relative to condition where X (Y) = 1 V		-42		dB
	$f = 1\text{ GHz}$		-35		dB
Gain	X = 50 MHz and 0 dBm, Y = 1 V		0.5		dB
	X = 1 GHz and 0 dBm, Y = 1 V		-1.33		dB
DC Linearity	X to output, Y = 1 V		1		% FS
Scale Factor	X = Y = 1 V		1		V/V
CMRR	$\pm 1\text{ V p-p}$, Y = 1 V, $f = 50\text{ MHz}$		42.1		dB
SUMMING INPUT (Z)	ZPLS, ZMNS				
Differential Voltage Range	Common mode from 2.5 V down to COMM		2		V p-p
Common-Mode Range	For full differential range	0		2.5	V
Gain	From Z to W, $f \leq 10\text{ MHz}$, 0 dBm, X = Y = 1 V		0.1		dB
Differential Input Impedance	$f = \text{dc}$		500		Ω
	$f = 2\text{ GHz}$		150		Ω
OUTPUTS (W)	WPLS, WMNS				
Differential Voltage Range	No external common mode		± 2		V
Common-Mode Output			$V_{POS} - 2.5$		V
Output Noise Floor	X = Y = 1 V dc				
	$f = 1\text{ MHz}$		-133		dBm/Hz
	$f = 1\text{ GHz}$		-133		dBm/Hz
	X = Y = 0				
	$f = 1\text{ MHz}$		-138		dBm/Hz
	$f = 1\text{ GHz}$		-138		dBm/Hz
Output Noise Voltage Spectral Density	X = Y = 0, $f = 1\text{ MHz}$		26.7		nV/ $\sqrt{\text{Hz}}$
Output Offset Voltage	Z = 0 V differential		19		mV
vs. Temperature			± 19		mV
Differential Output Impedance	$f = \text{dc}$		0		Ω
	$f = 200\text{ MHz}$		75		Ω
	$f = 2\text{ GHz}$		500		Ω
DYNAMIC CHARACTERISTICS					
Frequency Range	X, Y, Z to W	0		2	GHz
Slew Rate	W from -2.0 V to $+2.0\text{ V}$, $150\ \Omega$		8800		V/ μs
Settling Time	X stepped from -1 V to $+1\text{ V}$, Z = 0 V, $150\ \Omega$		2.1		ns
Second Harmonic Distortion	X (Y) = 0 dBm, Y (X) = 1 V, fund = 10 MHz		-60		dBc
	Fund = 200 MHz		-51		dBc
Third Harmonic Distortion	X (Y) = 0 dBm, Y (X) = 1 V, fund = 10 MHz		-61.5		dBc
	Fund = 200 MHz		-51.6		dBc

Parameter	Conditions	Min	Typ	Max	Unit
OIP3	Two-tone IP3 test; X (Y) = 100 mV p-p/tone (-10 dBm into 50 Ω), Y (X) = 1 f1 = 49 MHz, f = 50 MHz		26.5		dBm
	f1 = 999 MHz, f2 = 1 GHz		14		dBm
OIP2	f1 = 49 MHz, f = 50 MHz		45.5		dBm
	f1 = 999 MHz, f2 = 1 GHz		28		dBm
Output 1 dB Compression Point	X (Y) to W, Y (X) = 1 V, 50 MHz		15.1		dBm
	1 GHz		13.2		dBm
Group Delay	200 MHz		0.5		ns
	1 GHz		0.7		ns
Differential Gain Error, X/Y	f = 3.58 MHz		2.7		%
Differential Phase Error, X/Y	f = 3.58 MHz		0.23		Degrees
GAIN TRIMMING (α)	GADJ				
Nominal Bias	Unconnected		1.12		V
Input Range		0		2	V
Gain Adjust Range	Input 0 V to 2 V		9.5		dB
REFERENCE VOLTAGE	VMID		$V_{POS}/2$		V
Source Current	Common-mode for X, Y, Z = 2.5 V			50	mA
POWER AND ENABLE	V_{POS} , COMM, ENBL				
Supply Voltage Range		4.5		5.5	V
Total Supply Current	Common-mode for X, Y, Z = 2.5 V		135		mA
Disable Current	ENBL = 0 V		7.5		mA
Disable Threshold	High to low		1.5		V
Enable Response Time	Delay following high-to-low transition until device meets full specifications		150		ns
Disable Response Time	Delay following low-to-high transition until device produces full attenuation		50		ns

ABSOLUTE MAXIMUM RATINGS

Table 2.

Parameter	Rating
Supply Voltage, V_{POS}	5.5 V
ENBL	5.5 V
XPLS, XMNS, YPLS, YMNS, ZPLS, ZMNS	V_{POS}
GADJ	V_{POS}
Internal Power Dissipation	800 mW
θ_{JA} (With Pad Soldered to Board)	73°C/W
Maximum Junction Temperature	150°C
Operating Temperature Range	-40°C to +85°C
Storage Temperature Range	-65°C to +150°C
Lead Temperature (Soldering 60 sec)	300°C

Stresses at or above those listed under Absolute Maximum Ratings may cause permanent damage to the product. This is a stress rating only; functional operation of the product at these or any other conditions above those indicated in the operational section of this specification is not implied. Operation beyond the maximum operating conditions for extended periods may affect product reliability.

ESD CAUTION



ESD (electrostatic discharge) sensitive device. Charged devices and circuit boards can discharge without detection. Although this product features patented or proprietary protection circuitry, damage may occur on devices subjected to high energy ESD. Therefore, proper ESD precautions should be taken to avoid performance degradation or loss of functionality.

PIN CONFIGURATION AND FUNCTION DESCRIPTIONS

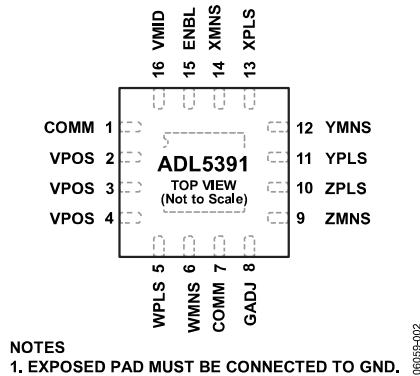

Figure 2. Pin Configuration

Table 3. Pin Function Descriptions

Pin No.	Mnemonic	Description
1, 7	COMM	Device Common. Connect via lowest possible impedance to external circuit common.
2 to 4	V _{POS}	Positive Supply Voltage. 4.5 V to 5.5 V.
5, 6	WPLS, WMNS	Differential Outputs.
8	GADJ	Denominator Scaling Input.
9, 10	ZMNS, ZPLS	Differential Intercept Inputs. Must be ac-coupled. Differential impedance 50 Ω nominal.
11, 12	YPLS, YMNS	Differential X-Multiplicand Inputs.
13, 14	XPLS, XMNS	Differential Y-Multiplicand Inputs.
15	ENBL	Chip Enable. High to enable.
16	VMID	V _{POS} /2 Reference Output. Connect decoupling capacitor to circuit common.
	EPAD	Exposed Pad. Exposed pad must be connected to GND.

TYPICAL PERFORMANCE CHARACTERISTICS

GADJ = open.

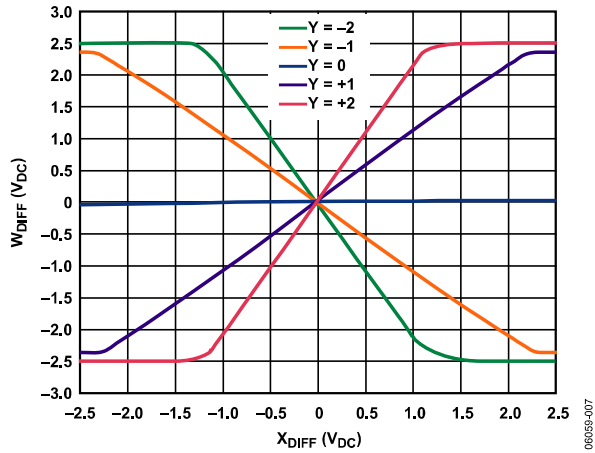

Figure 3. Full Range DC Cross Plots

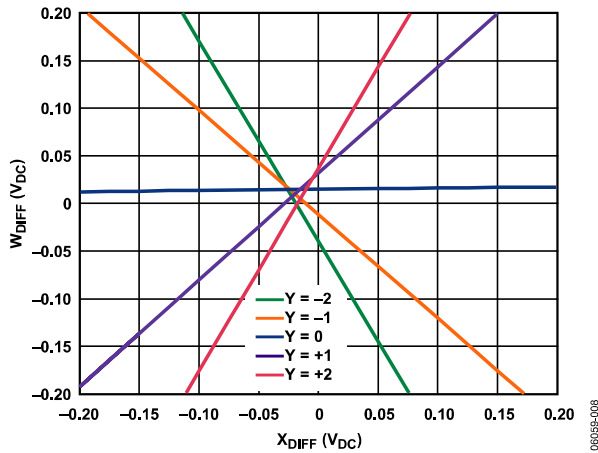

Figure 4. Magnified DC Cross Plots

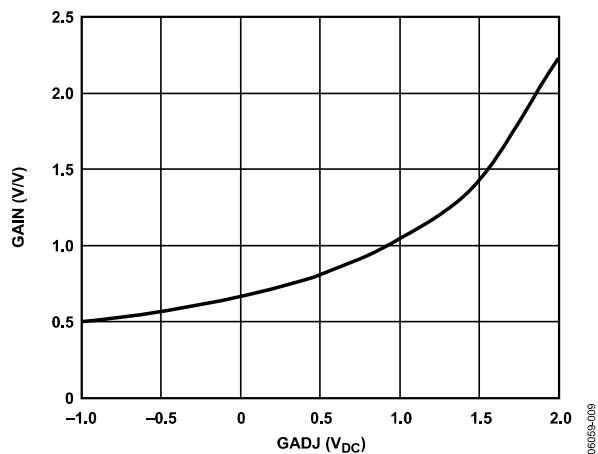

Figure 5. Gain vs. GADJ ($X = Y = 1$)

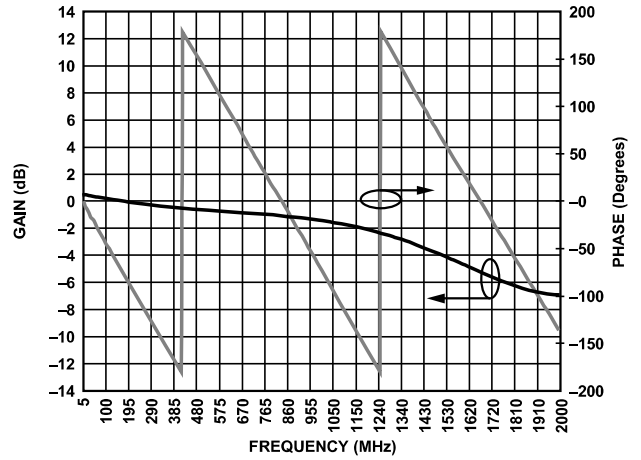

Figure 6. Gain and Phase vs. Frequency of X Swept and $Y = 1$ V, $Z = 0$ V, $P_{IN} = 0$ dBm

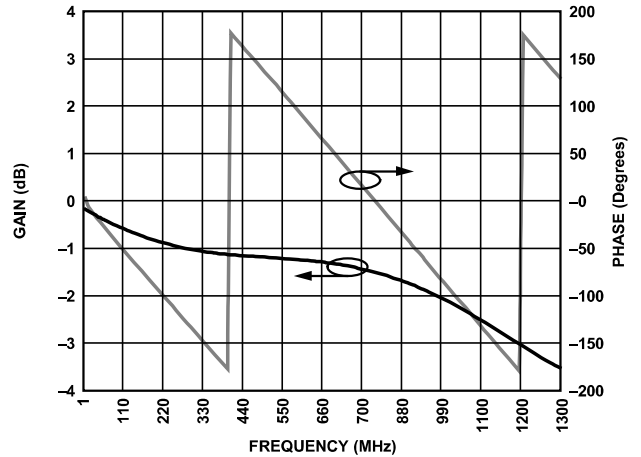

Figure 7. Gain and Phase vs. Frequency of Z Inputs, $X = 0$ V, $Y = 0$ V, $P_{IN} = 0$ dBm

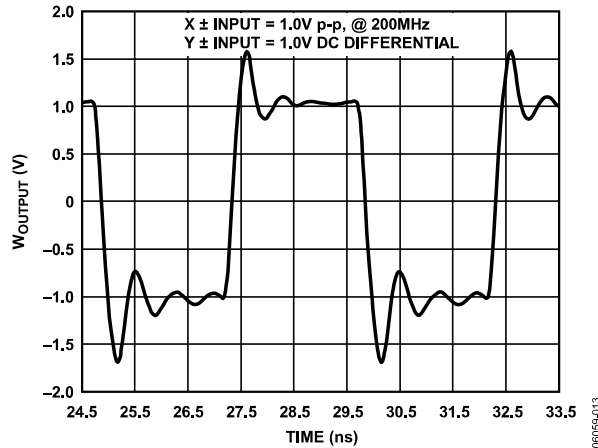

Figure 8. Large Signal Pulse Response

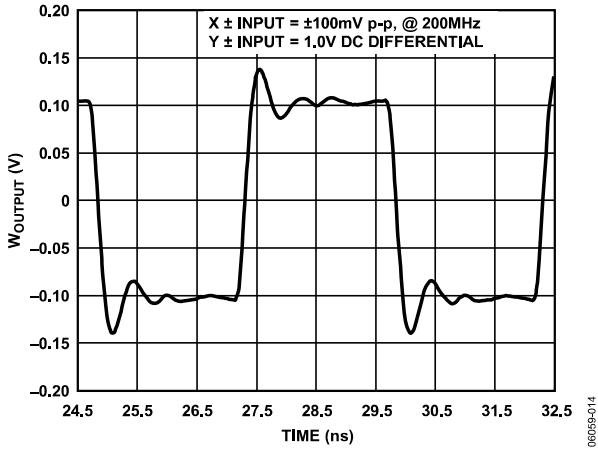

Figure 9. Small Signal Pulse Response

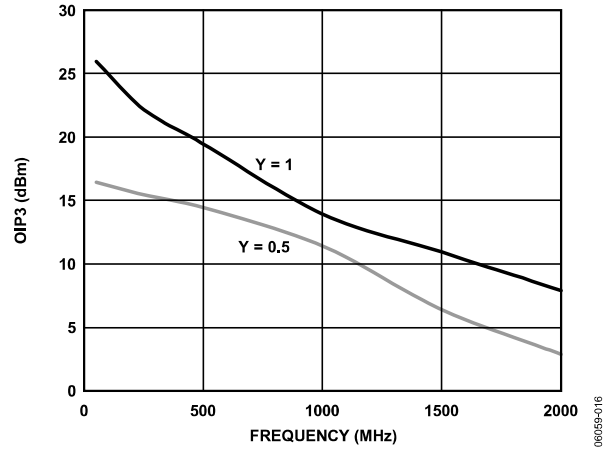

Figure 12. OIP3 vs. Frequency
Pin 0 dBm, Y = 1 V dc, 0.5 V dc

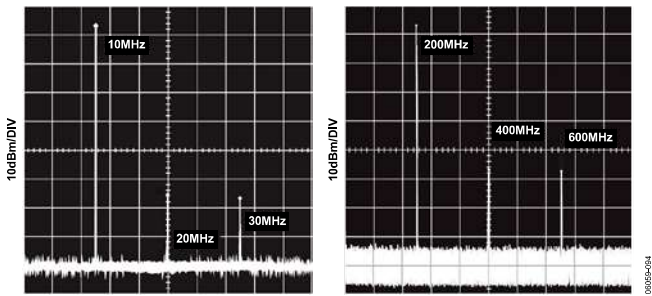

Figure 10. Harmonic Distortion at 10 MHz and 200 MHz;
0 dBm Input to X (Y) Channels

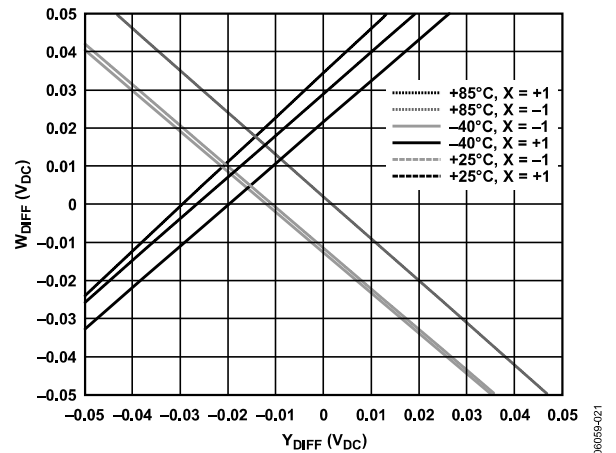

Figure 13. Z (W) Offset Over Temperature

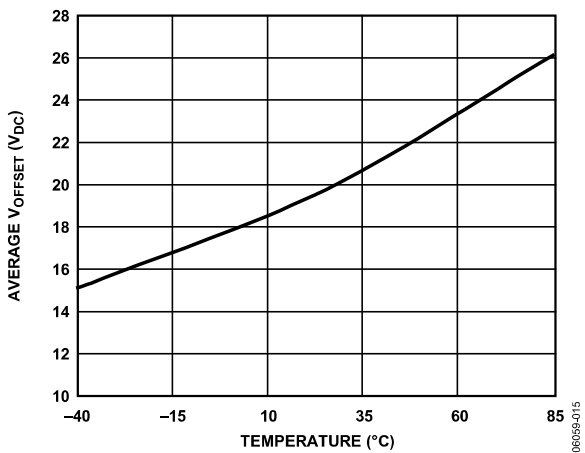

Figure 11. X (Y) Offset Drift vs. Temperature

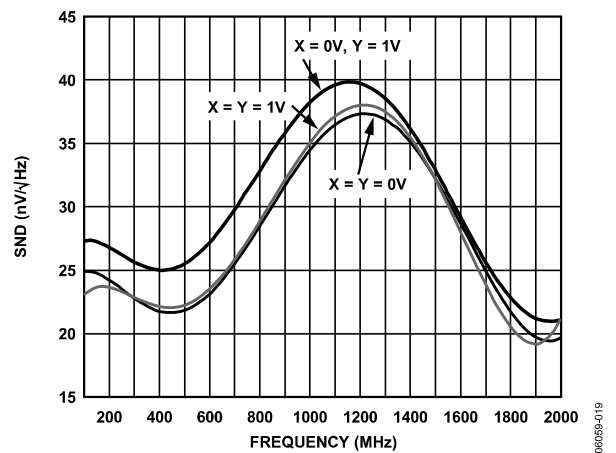
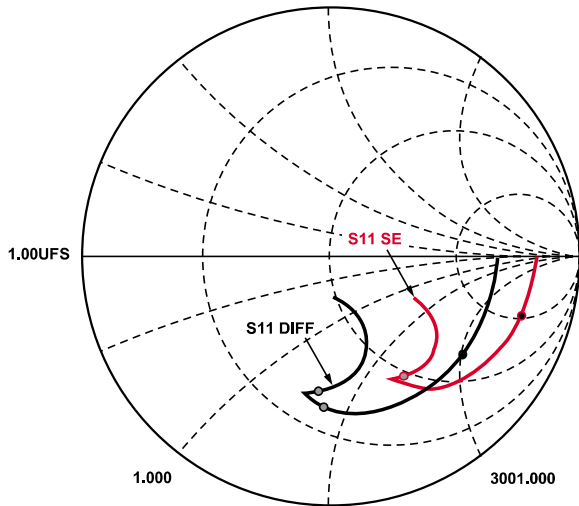

Figure 14. Noise vs. Frequency



201.000	0.654 U	-36.340 DEG	←
1001.000	0.594 U	-92.533 DEG	
1901.000	0.531 U	-94.448 DEG	
201.000	0.800 U	-17.218 DEG	←
2001.000	0.564 U	-58.167 DEG	

Figure 15. Input S11

060554-017

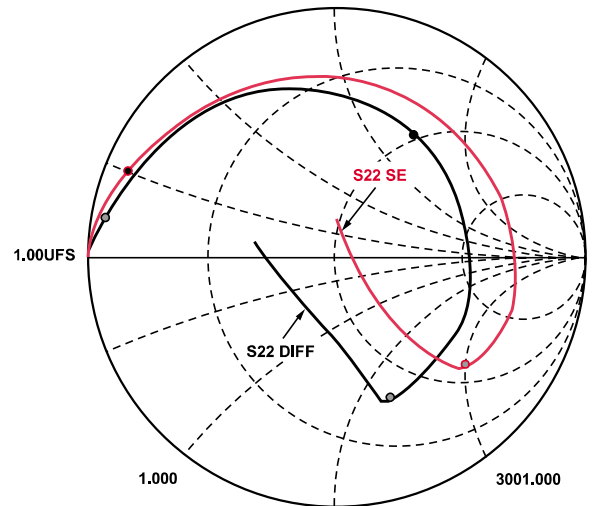

201.000	0.947 U	+170.736 DEG	←
1001.000	0.569 U	+58.257 DEG	
1901.000	0.597 U	-69.673 DEG	
201.000	0.905 U	+157.308 DEG	←
2001.000	0.663 U	-39.468 DEG	

Figure 16. Output S22

060554-018

THEORY OF OPERATION

BASIC THEORY

The multiplication of two analog variables is a fundamental signal processing function that has been around for decades. By convention, the desired transfer function is given by

$$W = \alpha XY/U + Z \quad (1)$$

where:

X and Y are the multiplicands.

U is the multiplier scaling factor.

α is the multiplier gain.

W is the product output.

Z is a summing input.

All the variables and the scaling factor have the dimension of volts.

In the past, analog multipliers, such as the [AD835](#), were implemented almost exclusively with a Gilbert Cell topology or a close derivative. The inherently asymmetric signal paths for X and Y inevitably create amplitude and delay imbalances between X and Y . In the ADL5391, the novel multiplier core provides absolute symmetry between X and Y , minimizing scaling and phasing differences inherent in the Gilbert Cell.

The simplified block diagram of the ADL5391 shows a main multiplier cell that receives inputs X and Y and a second multiplier cell in the feedback path around an integrating buffer. The inputs to this feedback multiplier are the difference of the output signal and the summing input, $W - Z$, and the internal scaling reference, U . At dc, the integrating buffer ensures that the output of both multipliers is exactly 0, therefore

$$(W - Z)xU = XY, \text{ or } W = XY/U + Z \quad (2)$$

By using a feedback multiplier that is identical to the main multiplier, the scaling is traced back solely to U , which is an accurate reference generated on-chip. As is apparent in Equation 2, noise, drift, or distortion that is common to both multipliers is rejected to first-order because the feedback multiplier essentially compensates the impairments generated in the main multiplier.

The scaling factor, U , is fixed by design to 1.12 V. However, the multiplier gain, α , can be adjusted by driving the GADJ pin with a voltage ranging from 0 V to 2 V. If left floating, then $\alpha = 1$ or 0 dB, and the overall scaling is simply $U = 1$ V. For $V_{GADJ} = 0$ V, the gain is lowered by approximately 4 dB; for $V_{GADJ} = 2$ V, the gain is raised by approximately 6 dB. Figure 5 shows the relationship between $\alpha(V/V)$ and V_{GADJ} .

The small-signal bandwidth from the inputs X , Y , and Z to the output W is a single-pole response. The pole is inversely proportional to α . For $\alpha = 1$ (GADJ floating), the bandwidth is about 2 GHz; for $\alpha > 1$, the bandwidth is reduced; and for $\alpha < 1$, the bandwidth is increased.

All input ports, X , Y , and Z , are differential and internally biased to midsupply, $V_{POS}/2$. The differential input impedance is 500 Ω up to 100 MHz, rolling off to 50 Ω at 2 GHz. All inputs can be driven in single-ended fashion and can be ac-coupled. In dc-coupled operation, the inputs can be biased to a common mode that is lower than $V_{POS}/2$. The bias current flowing out of the input pins to accommodate the lower common mode is subtracted from the 50 mA total available from the internal reference $V_{POS}/2$ at the VREF pin. Each input pin presents an equivalent 250 Ω dc resistance to $V_{POS}/2$. If all six input pins sit 1 V below $V_{POS}/2$, a total of $6 \times 1 \text{ V}/250 \Omega = 24 \text{ mA}$ must flow internally from VREF to the input pins.

Calibration

The dc offset of the ADL5391 is approximately 20 mV but changes over temperature and has variation from part to part (see Figure 4). It is generally not of concern unless the ADL5391 is operated down to dc (close to the point $X = 0$ V or $Y = 0$ V), where 0 V is expected on the output ($W = 0$ V). For example, when the ADL5391 is used as a VGA and a large amount of attenuation is needed, the maximum attenuation is determined by the input dc offset.

Applying the proper voltage on the Z input removes the W offset. Calibration can be accomplished by making the appropriate cross plots and adjusting the Z input to remove the offset.

Additionally, gain scaling can be adjusted by applying a dc voltage to the GADJ pin, as shown in Figure 5.

BASIC CONNECTIONS

Multiplier Connections

The best ADL5391 performance is achieved when the X , Y , and Z inputs and W output are driven differentially; however, they can be driven single-ended. Single-ended-to-differential transformations (or differential-to-single-ended transformations) can be done using a balun or active components, such as the [AD8313](#), the [AD8132](#) (both with operation down to dc), or the [AD8352](#) (for higher drive capability). If using the ADL5391 single-ended without ac coupling capacitors, the reference voltage of 2.5 V needs to be taken into account. Voltages above 2.5 V are positive voltages and voltages below 2.5 V are negative voltages. Care needs to be taken not to load the ADL5391 too heavily, the maximum reference current available is 50 mA.

Matching the Input/Output

The input and output impedances of the ADL5391 change over frequency, making it difficult to match over a broad frequency range (see Figure 15 and Figure 16). The evaluation board is matched for lower frequency operation, and the impedance change at higher frequencies causes the change in gain seen in Figure 6. If desired, the user of the ADL5391 can design a matching network to fit their application.

Wideband Voltage-Controlled Amplifier/Amplitude Modulator

Most of the data for the ADL5391 was collected by using it as a fast reacting analog VGA. Either X or Y inputs can be used for the RF input (and the other as the very fast analog control), because either input can be used from dc to 2 GHz. There is a linear relationship between the analog control and the output of the multiplier in the VGA mode. Figure 6 and Figure 7 show the dynamic range available in VGA mode (without optimizing the dc offsets).

The speed of the ADL5391 in VGA mode allows it to be used as an amplitude modulator. Either or both inputs can have modulation or CW applied. AM modulation is achieved by feeding CW into X (or Y) and adding AM modulation to the Y (or X) input.

Squaring and Frequency Doubling

Amplitude domain squaring of an input signal, E, is achieved simply by connecting the X and Y inputs in parallel to produce an output of E². The input can be single-ended, differential, or through a balun (frequency range and dynamic range can be limited if used single ended).

When the input is a sine wave E sin(ωt), a signal squarer behaves as a frequency doubler, because

$$[E \sin(\omega t)]^2 = \frac{E^2}{2} (1 - \cos(2\omega t)) \tag{3}$$

Ideally, when used for squaring and frequency doubling, there is no component of the original signals on the output. Because of internal offsets, this is not the case. If Equation 3 were rewritten to include these offsets, it could separate into three output terms (Equation 4).

$$[E \sin(\omega t) + OFST] \times [E \sin(\omega t) + OFST] = \frac{E^2}{2} [\cos(2\omega t)] + 2E \sin(\omega t) OFST + \left(OFST^2 + \frac{E^2}{2} \right) \tag{4}$$

where:

The dc component is OFST² + E²/2.

The input signal bleedthrough is 2E sin(ωt) OFST.

The input squared is E²/2 [cos(2ωt)].

The dc component of the output is related to the square of both the offset (OFST) and the signal input amplitude (E). The offset can be found in Figure 4 and is approximately 20 mV. The

second harmonic output grows with the square of the input amplitude, and the signal bleedthrough grows proportionally with the input signal. For smaller signal amplitudes, the signal bleedthrough can be higher than the second harmonic component. As the input amplitude increases, the second harmonic component grows much faster than the signal bleedthrough and becomes the dominant signal at the output. If the X and Y inputs are driven too hard, third harmonic components will also increase.

For best performance creating harmonics, the ADL5391 should be driven differentially. Figure 17 shows the performance of the ADL5391 when used as a harmonic generator (the evaluation board was used with R9 and R10 removed and R2 = 56.2 Ω). If dc operation is necessary, the ADL5391 can be driven single ended (without the dc blocks). The flatness of the response over a broad frequency range depends on the input/output match. The fundamental bleed through not only depends on the amount of power put into the device but also depends on matching the unused differential input/output to the same impedance as the used input/output. Figure 18 shows the performance of the ADL5391 when driven single ended (without ac coupling capacitors), and Figure 19 shows the schematic of the setup. A resistive input/output match were used to match the input from dc to 1 GHz and the output from dc to 2 GHz. Reactive matching can be used for more narrow frequency ranges. When matching the input/output of the ADL5391, care needs to be taken not to load the ADL5391 too heavily; the maximum reference current available is 50 mA.

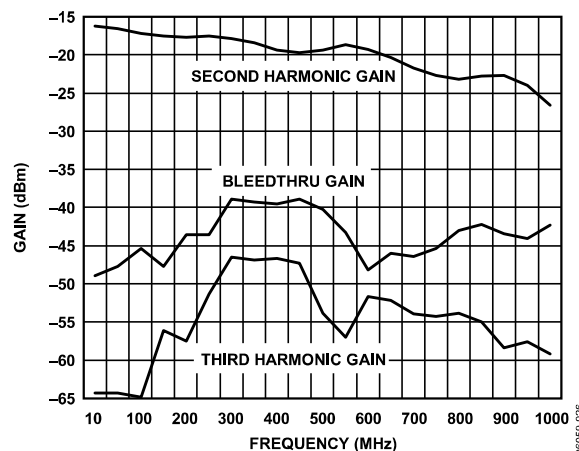

Figure 17. ADL5391 Used as a Harmonic Generator

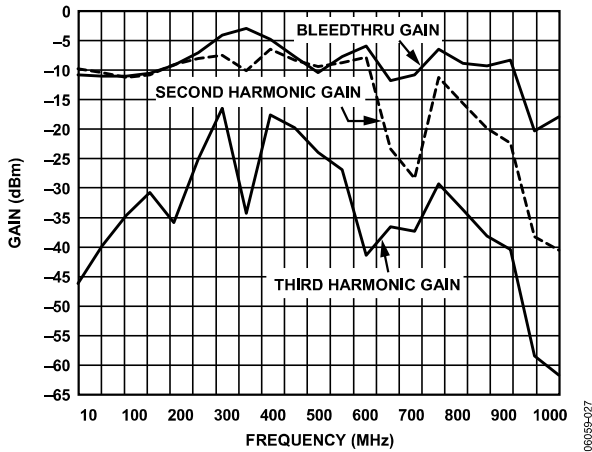

Figure 18. Single-Ended (DC) ADL5391 Used as a Harmonic Generator

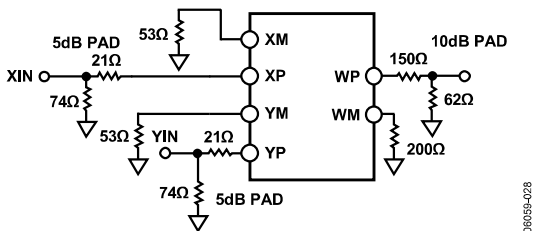

Figure 19. Setup for Single-Ended Data

Use as a Detector

The ADL5391 can be used as a square law detector. When amplitude squaring is performed, there are components of the multiplier output that correlate to the signal bleedthrough and second harmonic, as seen in Equation 4. However, as noted in the Squaring and Frequency Doubling section, there is also a dc component that is directly related to the offset and the squared input magnitude. If a signal is split and feed into the X and Y inputs and a low-pass filter were place on the output, the resulting dc signal would be directly related to the square of the input magnitude. The intercept of the response will shift slightly from part to part (and over temperature) with the offset, but this can

be removed through calibration. Figure 20 shows the response of the ADL5391 as a square law detector, Figure 21 shows the error vs. the input power, and Figure 22 shows the configuration used.

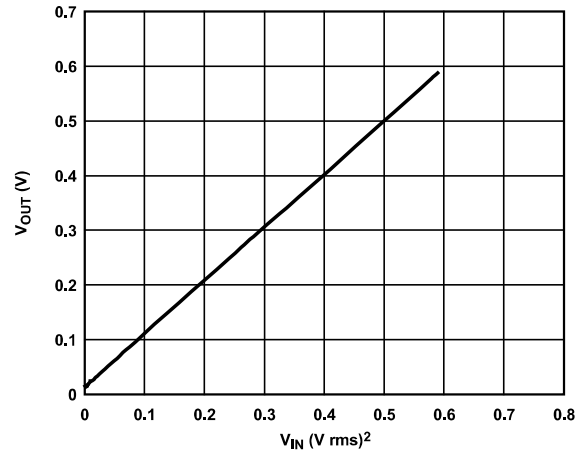

Figure 20. ADL5391 Used as Square Law Detector DC Output vs. Square of Input

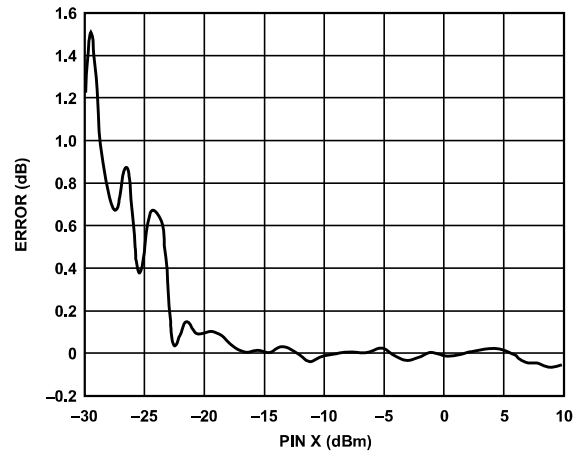

Figure 21. ADL5391 Used as a Square Law Detector Error vs. Power Input

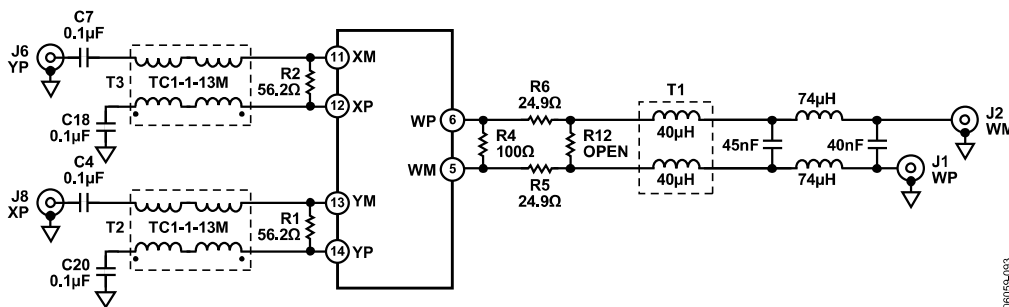

Figure 22. Schematic for ADL5391 Used as Square Law Detector

EVALUATION BOARD

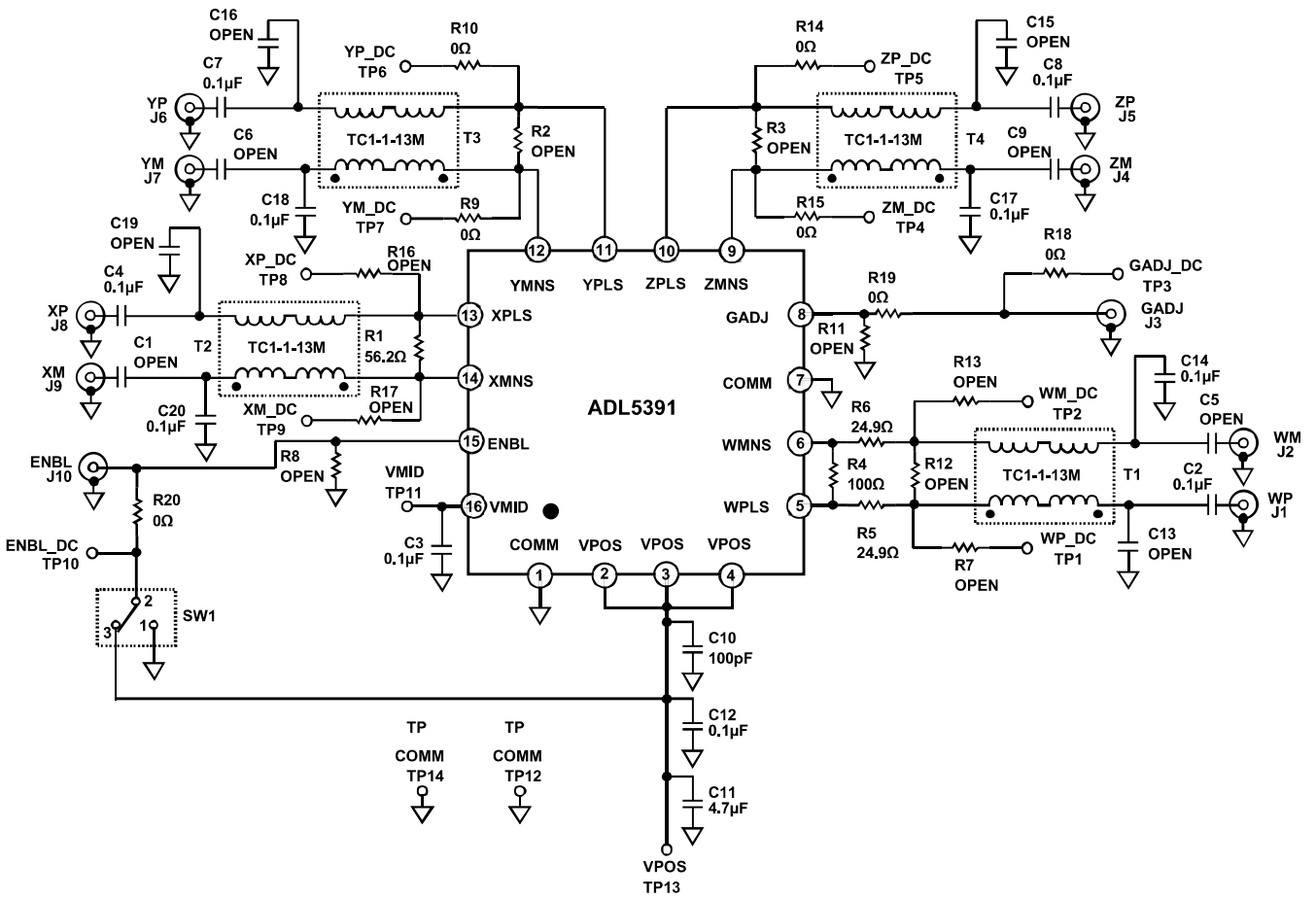

Figure 23. ADL5391-EVALZ Evaluation Board Schematic

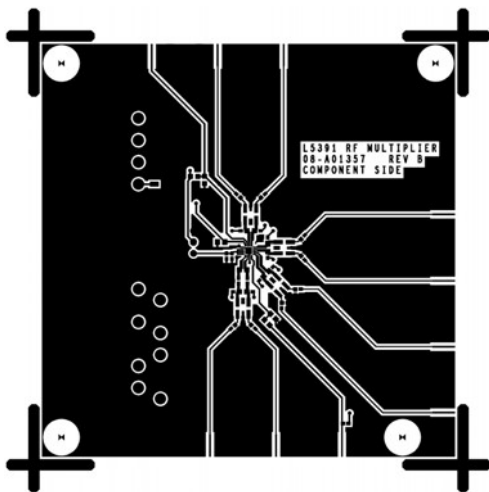

Figure 24. Component Side Metal of Evaluation Board

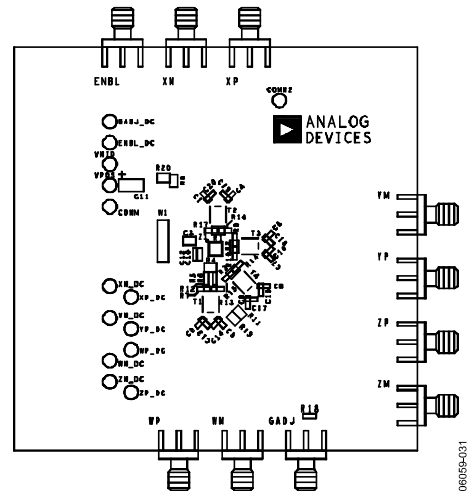

Figure 25. Component Side Silkscreen of Evaluation Board

Table 4. Evaluation Board Configuration Options

Component	Function	Part Number	Default Value
J1, J5, J6, J8	SMA connectors for single-ended, high frequency operation. If J5 and J6 are used, R9, R10, R14, and R15 should be removed. R2 and R3 should also be populated to match the inputs. If used in broadband operation, C4, C7, C8, and C2 need to be replaced with 0 Ω resistors.	TC1-1-13M+ Mini-Circuits	WP, ZP, YP, XP
J2, J4, J7, J9	SMA connectors for broadband differential operation. If these are used, baluns should be removed and jumped over using 0 Ω resistors, and C14, C15, C18, and C20 should be removed.		WM, ZM, YM, XM
J3	SMA connector for connection to GADJ.		GADJ
T1, T2, T3, T4	Single-ended-to-differential transformation for high frequency ac operation. If dc operation is necessary, the baluns can be removed and jumped over using 0 Ω resistors.		T3 and T4 are populated, but the Y and Z inputs are set up for dc operation.
C2, C4, C7, C8, C14, C17, C18, C20	DC block capacitors.		0.1 μ F, 0402 capacitors
C1, C5, C6, C9, C13, C15, C16, C19	Not installed, dc block capacitors.		Open, 0402 capacitors
R9, R10, R14, R15, R18	Snubbing resistors.		0 Ω , 0402 resistors
R19, R20	Snubbing resistors.		0 Ω , 0603 resistors
R7, R13, R16, R17	Snubbing resistors.		Open, 0402 resistors
C10	Filter capacitor.		100 pF, 0402 capacitor
C12	Filter capacitor.		0.1 μ F, 0402 capacitor
C3	Filter capacitor.		0.1 μ F, 0603 capacitor
C11	Filter capacitor.		4.7 μ F, 3216 capacitor
R1	Matching resistor.		56.2 Ω , 0603 resistor
R2, R3, R12	Matching resistors. Input impedance to X, Y, and Z inputs are the same. For the same frequency, R1, R2, and R3 should be the same.		Open, 0603 resistors
R5, R6	Matching resistors.		24.9 Ω , 0402 resistors
R4	Matching resistor.		100 Ω , 0603 resistor
R8, R11	Can be used for voltage divider or filtering.		Open, 0603 resistors
SW1	Enable switch: enable = 5 V, disable = 0 V.		SW1 installed
TP1, TP2, TP4, TP5, TP6, TP7, TP8, TP9	Green test loop.		WP_DC, WM_DC, ZM_DC, ZP_DC, YP_DC, YM_DC, XP_DC, XM_DC
TP13	Red test loop.	V _{POS}	
TP12, TP14	Black test loops.	COMM	
TP3, TP10, TP11	Yellow test loops.	GADJ_DC, ENBL_DC, VMID	
DUT	ADL5391.	ADL5391ACPZ	

OUTLINE DIMENSIONS

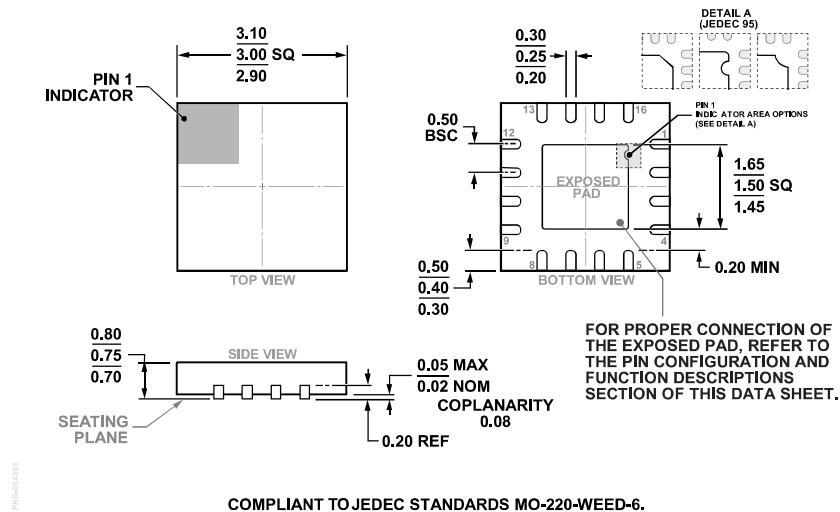

Figure 26. 16-Lead Lead Frame Chip Scale Package [LFCSP]
 3 mm x 3 mm Body and 0.75 mm Package Height
 (CP-16-27)

Dimensions shown in millimeters

ORDERING GUIDE

Model ¹	Temperature Range	Package Description	Package Option	Ordering Quantity
ADL5391ACPZ-R2	-40°C to +85°C	16-Lead LFCSP	CP-16-27	250
ADL5391ACPZ-R7	-40°C to +85°C	16-Lead LFCSP	CP-16-27	1,500
ADL5391ACPZ-WP	-40°C to +85°C	16-Lead LFCSP	CP-16-27	50
ADL5391-EVALZ		Evaluation Board		1

¹ Z = RoHS Compliant part.