

PXT3906 TRANSISTOR (PNP)

FEATURES

- Compliment to PXT3904
- Low current
- Low voltage

MARKING: 2A

MAXIMUM RATINGS (T_a=25°C unless otherwise noted)

Symbol	Parameter	Value	Units
V _{CB0}	Collector-Base Voltage	-40	V
V _{CEO}	Collector-Emitter Voltage	-40	V
V _{EBO}	Emitter-Base Voltage	-6	V
I _c	Collector Current -Continuous	-0.2	A
P _c	Collector Power Dissipation	0.5	W
R _{θJA}	Thermal resistance from junction to ambient	250	°C/W
T _J , T _{stg}	Operation Junction and Storage Temperature Range	-55-150	°C

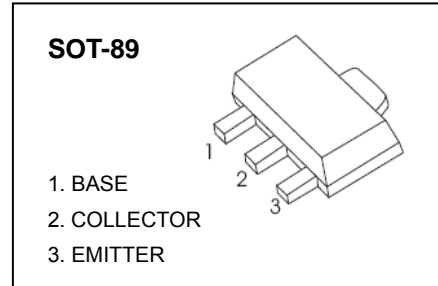

ELECTRICAL CHARACTERISTICS (T_a=25°C unless otherwise specified)

Parameter	Symbol	Test conditions	Min	Typ	Max	Unit
Collector-base breakdown voltage	V _{(BR)CBO}	I _C =-10μA, I _E =0	-40			V
Collector-emitter breakdown voltage	V _{(BR)CEO}	I _C =-1mA, I _B =0	-40			V
Emitter-base breakdown voltage	V _{(BR)EBO}	I _E =-10μA, I _C =0	-6			V
Collector cut-off current	I _{CBO}	V _{CB} =-30V, I _E =0			-0.05	μA
9a β_{DC} cut-off current	I _{EBO}	V _{EB} =-6V, I _C =0			-0.05	μA
7 c β_{DC} cut-off current	I _{CEX}	V _{CB} =-30V, V _{BE(off)} =-3V			-0.05	μA
DC current gain	h _{FE(1)}	V _{CE} =-1V, I _C =-0.1mA	60			
	h _{FE(2)}	V _{CE} =-1V, I _C =-1mA	80			
	h _{FE(3)}	V _{CE} =-1V, I _C =-10mA	100		300	
	h _{FE(4)}	V _{CE} =-1V, I _C =-50mA	60			
	h _{FE(5)}	V _{CE} =-1V, I _C =-100mA	30			
Collector-emitter saturation voltage	V _{CE(sat)1}	I _C =-10mA, I _B =-1mA			-0.25	V
	V _{CE(sat)2}	I _C =-50mA, I _B =-5mA			-0.4	V
Base-emitter saturation voltage	V _{BE(sat)1}	I _C =-10mA, I _B =-1mA	-0.65		-0.85	V
	V _{BE(sat)2}	I _C =-50mA, I _B =-5mA			-0.95	V
Transition frequency	f _T	V _{CE} =-20V, I _C =-10mA, f=100MHz	250			MHz
Collector capacitance	C _c	V _{CB} =-5V, I _E =0, f=1MHz			4.5	pF
Emitter capacitance	C _e	V _{EB} =-0.5V, I _C =0, f=1MHz			10	pF
Noise figure	NF	V _{CE} =-5V, I _C =-0.1mA, f=10Hz-15.7kHz, R _S =1KΩ			4	dB
Delay time	t _d	I _C =-10mA, I _{B1} =-I _{B2} =-1mA			35	nS
Rise time	t _r				35	nS
Storage time	t _s				225	nS
Fall time	t _f				75	nS

Physical Dimensions

SOT-89

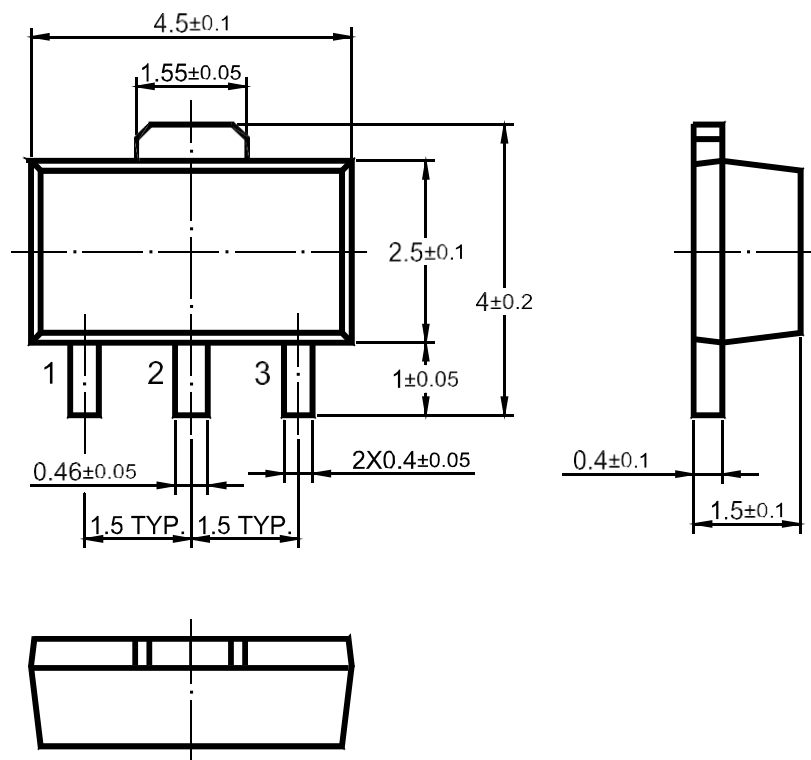

Dimensions in mm