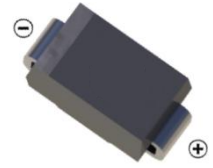
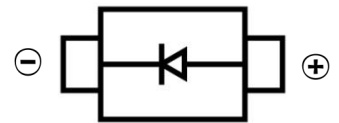

SCHOTTKY BARRIER DIODE
FEATURES

- Small Surface Mount device
- Low power loss, high efficiency
- High forward surge current capability
- For use in low voltage, high frequency inverters, free wheeling, and polarity protection applications

SMB
MECHANICAL DATA

- Case: SMB(DO-214AA)
- Case Material: Molded Plastic. UL flammability
- Classification Rating: 94V-0
- Weight: 0.088 grams (approximate)

MAXIMUM RATINGS (T_A = 25°C unless otherwise noted)

Parameter	Symbol	SS52B	SS53B	SS54B	SS55B	SS56B	SS58B	SS510B	SS515B	SS520B	Unit
Repetitive peak reverse	V _{RRM}	20	30	40	50	60	80	100	150	200	V
DC Reverse Voltage	V _R	20	30	40	50	60	80	100	150	200	V
RMS Reverse Voltage	V _{RMS}	14	21	28	35	42	56	70	105	140	V
Non-Repetitive Peak Forward Surge Current @ t = 8.3 ms	I _{FSM}	150									A
Mean rectifying current	I _F	5.0									A
Thermal Resistance	R _{θJA}	60									°C/W
Thermal Resistance	R _{θJL}	20									°C/W
Junction Temperature	T _J	-55 ~+125				-55 ~+150					°C
Storage Temperature	T _{STG}	-55 ~+150									°C

ELECTRICAL CHARACTERISTICS (T_A = 25°C unless otherwise specified)

Parameter	Symbol	SS52B	SS53B	SS54B	SS55B	SS56B	SS58B	SS510B	SS515B	SS520B	Unit	Conditions
Forward voltage	V _F	0.55			0.70		0.85		0.95		V	I _F =5A
Reverse current T _A =25°C	I _R	0.5				0.2					mA	V=V _R
Reverse current T _A =100°C	I _R	20			10					mA		
Junction capacitance	C _J	500			350					pF	V=4V, f=1MHz	

Notes: Thermal resistance from junction to ambient and from junction to lead mounted on P.C.B. with 0.27" x 0.27" (7.0 mm x 7.0 mm)copper pad areas

SCHOTTKY BARRIER DIODE

Typical Characteristics

FIG.1: FORWARD CURRENT DERATING CURVE

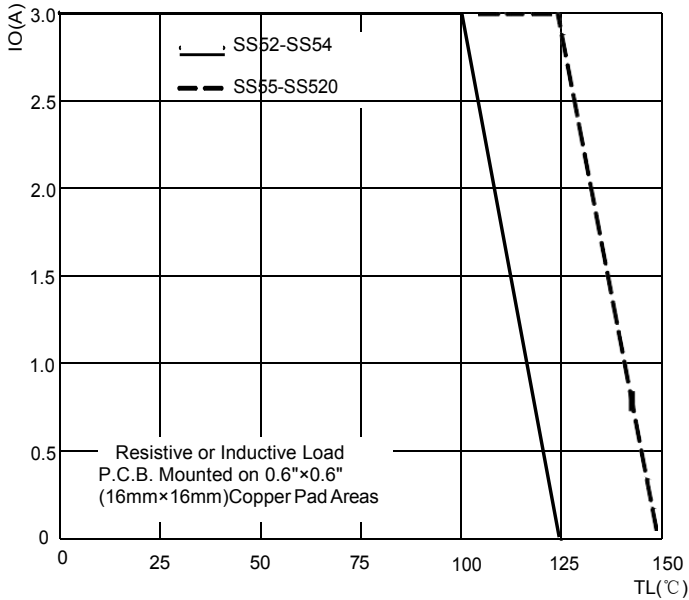

FIG.2: MAXIMUM NON-REPETITIVE FORWARD URGE CURRENT

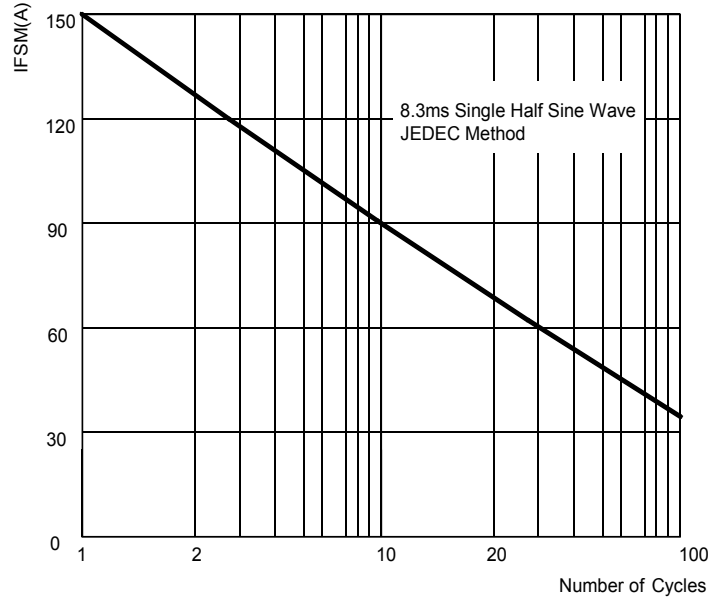

FIG.3: TYPICAL FORWARD CHARACTERISTICS

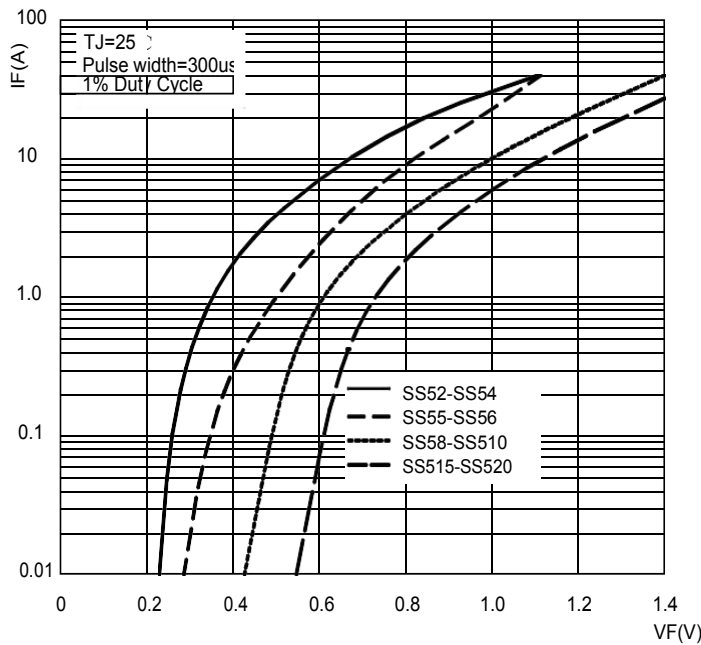
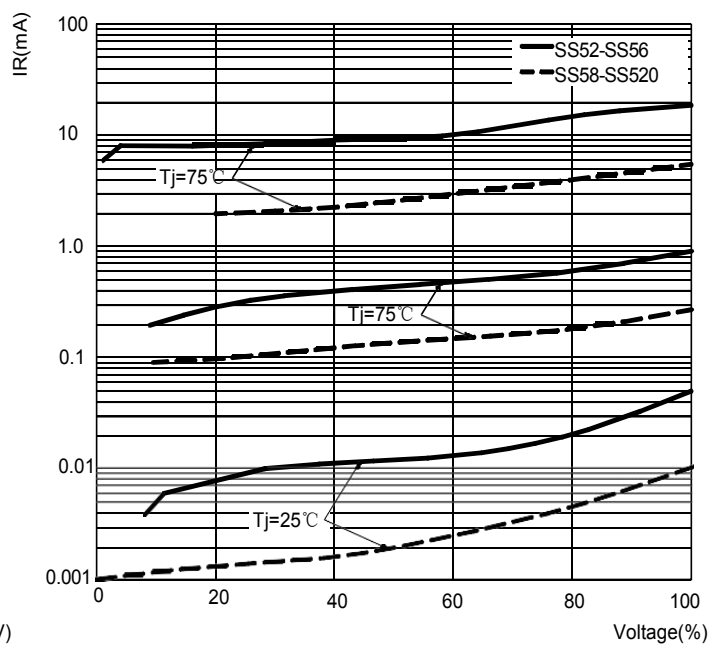
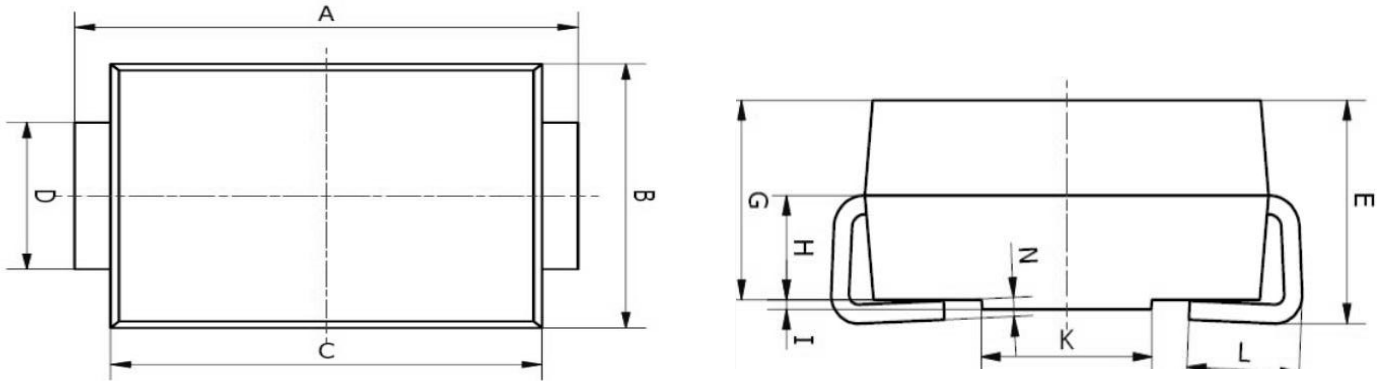

FIG.4: TYPICAL REVERSE CHARACTERISTICS



SCHOTTKY BARRIER DIODE

SMB Package Outline Dimensions



Symbol	Dimensions In Millimeters		Dimensions In Inches	
	Min.	Max.	Min.	Max.
A	5.00	5.45	0.197	0.215
B	3.20	4.00	0.126	0.157
C	4.30	4.70	0.169	0.185
D	1.80	2.20	0.071	0.087
E	2.20	2.50	0.087	0.098
G	1.90	2.30	0.075	0.090
H	0.95	1.25	0.037	0.049
I	0.05	0.15	0.002	0.006
K	1.70	2.10	0.067	0.083
L	0.90	1.60	0.035	0.063
N	0.10	0.30	0.004	0.012

SMB Suggested Pad Layout

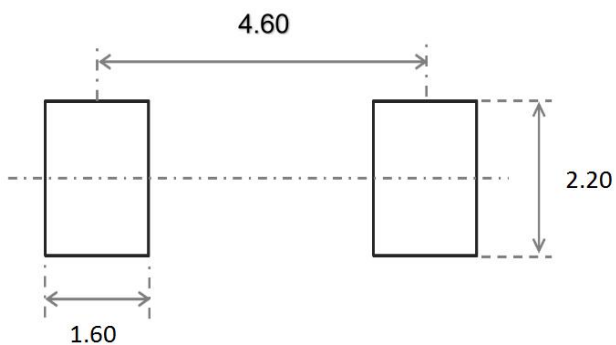

Note:

1. Controlling dimension: in millimeters
2. General tolerance: $\pm 0.05\text{mm}$
3. The pad layout is for reference purposes only

SCHOTTKY BARRIER DIODE

SMB Tape and Reel

SMB Embossed Carrier Tape

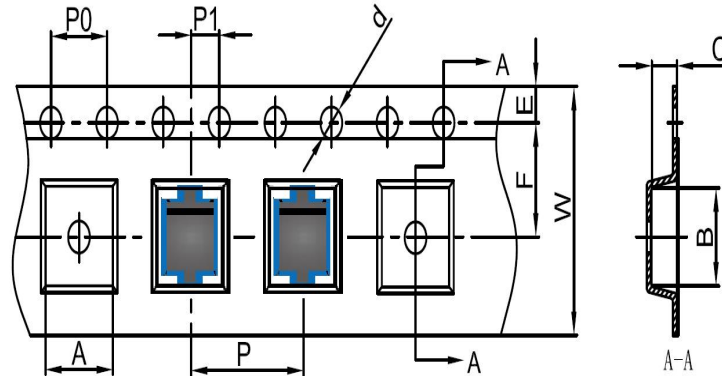

DIMENSIONS ARE IN MILLIMETER										
TYPE	A	B	C	d	E	F	P0	P	P1	W
SMB	4.10	5.50	2.58	Ø1.50	1.75	5.50	4.00	8.00	2.00	12.00
TOLERANCE	±0.1	±0.1	±0.1	±0.1	±0.1	±0.1	±0.1	±0.1	±0.1	±0.1

SMB Tape Leader and Trailer

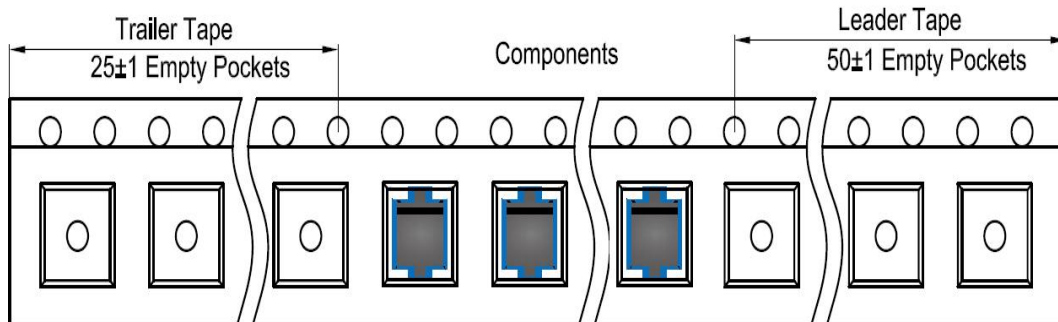

SMB Reel

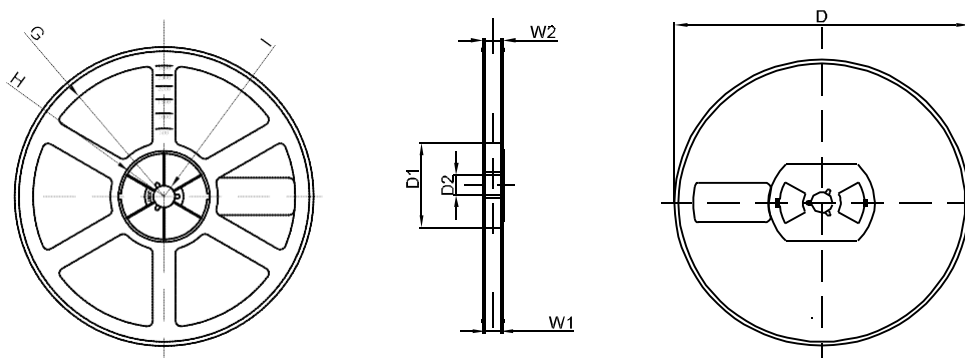

DIMENSIONS ARE IN MILLIMETER								
REEL OPTION	D	D1	D2	G	H	I	W1	W2
13" DIA	Ø330	75.0	13.00	R165	R37.50	R6.50	12.40	17.60
TOLERANCE	±2	±1	±1	±1	±1	±1	±1	±1