



AiP74LVC2G126

Dual Buffer/Line Driver; 3-state

Product Specification

Specification Revision History:

Version	Date	Description
2017-05-A1	2017-05	New
2021-05-A2	2021-05	Add VSSOP8 ordering information
2021-12-A3	2021-12	Modify ordering information
2022-02-A4	2022-02	Modify ambient temperature to $-40^{\circ}\text{C}\sim+105^{\circ}\text{C}$ and add electrical characteristics of $-40^{\circ}\text{C}\sim+105^{\circ}\text{C}$
2022-03-A5	2022-03	Modify ordering information note 1



1、 General Description

The AiP74LVC2G126 is a dual non-inverting buffer/line driver with 3-state outputs. Each 3-state output is controlled by an output enable input (pin nOE). A LOW-level at pin nOE causes the output to assume a high-impedance OFF-state.

Inputs can be driven from either 3.3V or 5V devices. This feature allows the use of the AiP74LVC2G126 as a translator in a mixed 3.3V and 5V environment.

It is fully specified for partial power-down applications using I_{OFF} . The I_{OFF} circuitry disables the output, preventing a damaging backflow current through the device when it is powered down.

Features:

- Wide supply voltage range from 1.65V to 5.5V
- 5V tolerant input/output for interfacing with 5V logic
- $\pm 24\text{mA}$ output drive ($V_{CC}=3.0\text{V}$)
- CMOS low power consumption
- Latch-up performance exceeds 250mA
- Direct interface with TTL levels
- Inputs accept voltages up to 5V
- Specified from -40°C to $+105^{\circ}\text{C}$
- Packaging information: TSSOP8/VSSOP8

Ordering Information:

Tube packing specifications:

Part number	Packaging form	Marking code	Tube quantity	Boxed tube quantity	Boxed quantity	Notes
AiP74LVC2G126TA8.TB	TSSOP8	BSXX	96 PCS/tube	200 tube/box	19200 PCS/box	Dimensions of plastic enclosure: 3.0mm×3.0mm Pin spacing: 0.65mm

Reel packing specifications:

Part number	Packaging form	Marking code	Reel quantity	Boxed reel quantity	Notes
AiP74LVC2G126TA8.TR	TSSOP8	BSXX	3000 PCS/reel	3000 PCS/box	Dimensions of plastic enclosure: 3.0mm×3.0mm Pin spacing: 0.65mm
AiP74LVC2G126YA8.TR	VSSOP8	BSXX	3000 PCS/reel	3000 PCS/box	Dimensions of plastic enclosure: 2.0mm×2.3mm Pin spacing:0.50mm

Note 1: "XX" refers to variable content, meaning year and package batch serial number.

Note 2: If the physical information is inconsistent with the ordering information, please refer to the actual product.



2、Block Diagram And Pin Description

2.1、Block Diagram

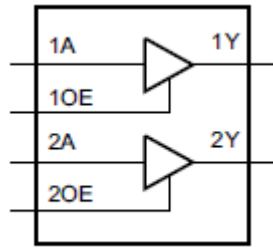

Figure 1. Logic symbol

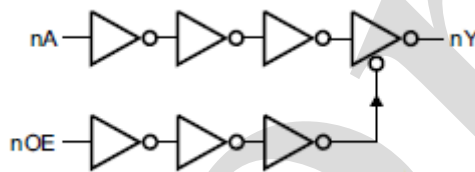
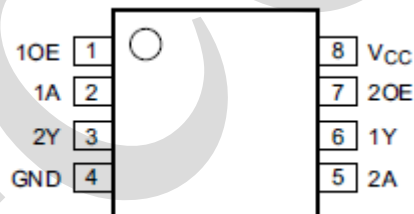

Figure 2. Logic diagram (one gate)

2.2、Pin Configurations



2.3、Pin Description

Pin No.	Pin Name	Description
1	1OE	output enable input (active HIGH)
2	1A	data input
3	2Y	data output
4	GND	ground (0V)
5	2A	data input
6	1Y	data output
7	2OE	output enable input (active HIGH)
8	V _{CC}	supply voltage



2.4、Function Table

Input		Output
nOE	nA	nY
H	L	L
H	H	H
L	X	Z

Note: H=HIGH voltage level; L=LOW voltage level; X=don't care; Z=high-impedance OFF-state.

3、Electrical Parameter

3.1、Absolute Maximum Ratings

(Voltages are referenced to GND(ground=0V), unless otherwise specified.)

Parameter	Symbol	Conditions	Min.	Max.	Unit
supply voltage	V_{CC}	-	-0.5	+6.5	V
input clamping current	I_{IK}	$V_I < 0V$	-50	-	mA
input voltage	V_I	-	-0.5	+6.5	V
Output clamping current	I_{OK}	$V_O > V_{CC}$ or $V_O < 0V$	-	± 50	mA
output voltage	V_O	Active mode	-0.5	$V_{CC}+0.5$	V
		Power-down mode	-0.5	+6.5	V
output current	I_O	$V_O=0V$ to V_{CC}	-	± 50	mA
supply current	I_{CC}	-	-	100	mA
ground current	I_{GND}	-	-100	-	mA
storage temperature	T_{stg}	-	-65	+150	°C
total power dissipation	P_{tot}	-	-	300	mW
Soldering temperature	T_L	10s	250		°C

Note:

[1] When $V_{CC}=0V$ (Power-down mode), the output voltage can be 5.5V in normal operation.

[2] For TSSOP8 package: above 55°C the value of P_{tot} derates linearly with 2.5mW/K.

[3] For VSSOP8 package: above 110°C the value of P_{tot} derates linearly at 8mW/K.

3.2、Recommended Operating Conditions

Parameter	Symbol	Conditions	Min.	Typ.	Max.	Unit
supply voltage	V_{CC}	-	1.65	-	5.5	V
input voltage	V_I	-	0	-	5.5	V
output voltage	V_O	Active mode	0	-	V_{CC}	V
		$V_{CC}=0V$; Power-down mode	0	-	5.5	V
ambient temperature	T_{amb}	-	-40	-	+105	°C
input transition rise and fall rate	$\Delta t/\Delta V$	$V_{CC}=1.65V$ to $2.7V$	-	-	20	ns/V
		$V_{CC}=2.7V$ to $5.5V$	-	-	10	ns/V



3.3. Electrical Characteristics

3.3.1. DC Characteristics 1

($T_{amb} = -40^{\circ}\text{C}$ to $+85^{\circ}\text{C}$, voltages are referenced to GND (ground=0V), unless otherwise specified.)

Parameter	Symbol	Conditions	Min.	Typ.	Max.	Unit	
HIGH-level input voltage	V_{IH}	$V_{CC}=1.65\text{V}$ to 1.95V	$0.65 \times V_{CC}$	-	-	V	
		$V_{CC}=2.3\text{V}$ to 2.7V	1.7	-	-	V	
		$V_{CC}=2.7\text{V}$ to 3.6V	2.0	-	-	V	
		$V_{CC}=4.5\text{V}$ to 5.5V	$0.7 \times V_{CC}$	-	-	V	
LOW-level input voltage	V_{IL}	$V_{CC}=1.65\text{V}$ to 1.95V	-	-	$0.35 \times V_{CC}$	V	
		$V_{CC}=2.3\text{V}$ to 2.7V	-	-	0.7	V	
		$V_{CC}=2.7\text{V}$ to 3.6V	-	-	0.8	V	
		$V_{CC}=4.5\text{V}$ to 5.5V	-	-	$0.3 \times V_{CC}$	V	
HIGH-level output voltage	V_{OH}	$V_I = V_{IH}$ or V_{IL}	$I_O = -100\mu\text{A}$; $V_{CC}=1.65\text{V}$ to 5.5V	$V_{CC} - 0.1$	-	-	V
			$I_O = -4\text{mA}$; $V_{CC}=1.65\text{V}$	1.2	-	-	V
			$I_O = -8\text{mA}$; $V_{CC}=2.3\text{V}$	1.9	-	-	V
			$I_O = -12\text{mA}$; $V_{CC}=2.7\text{V}$	2.2	-	-	V
			$I_O = -24\text{mA}$; $V_{CC}=3.0\text{V}$	2.3	-	-	V
			$I_O = -32\text{mA}$; $V_{CC}=4.5\text{V}$	3.8	-	-	V
LOW-level output voltage	V_{OL}	$V_I = V_{IH}$ or V_{IL}	$I_O = 100\mu\text{A}$; $V_{CC}=1.65\text{V}$ to 5.5V	-	-	0.10	V
			$I_O = 4\text{mA}$; $V_{CC}=1.65\text{V}$	-	-	0.45	V
			$I_O = 8\text{mA}$; $V_{CC}=2.3\text{V}$	-	-	0.30	V
			$I_O = 12\text{mA}$; $V_{CC}=2.7\text{V}$	-	-	0.40	V
			$I_O = 24\text{mA}$; $V_{CC}=3.0\text{V}$	-	-	0.55	V
			$I_O = 32\text{mA}$; $V_{CC}=4.5\text{V}$	-	-	0.55	V
input leakage current	I_I	$V_I = 5.5\text{V}$ or GND; $V_{CC} = 0\text{V}$ to 5.5V	-	± 0.1	± 1	μA	
OFF-state output current	I_{OZ}	$V_I = V_{IH}$ or V_{IL} ; $V_O = 5.5\text{V}$ or GND; $V_{CC} = 3.6\text{V}$	-	± 0.1	± 2	μA	
power-off leakage current	I_{OFF}	V_I or $V_O = 5.5\text{V}$; $V_{CC} = 0\text{V}$	-	± 0.1	± 2	μA	
supply current	I_{CC}	$V_I = 5.5\text{V}$ or GND; $V_{CC} = 1.65\text{V}$ to 5.5V ; $I_O = 0\text{A}$	-	0.1	4	μA	
additional supply current	ΔI_{CC}	per pin; $V_I = V_{CC} - 0.6\text{V}$; $I_O = 0\text{A}$; $V_{CC} = 2.3\text{V}$ to 5.5V	-	5	500	μA	
input capacitance	C_I	-	-	2	-	pF	

Note: All typical values are measured at $V_{CC} = 3.3\text{V}$ and $T_{amb} = 25^{\circ}\text{C}$.



3.3.2、DC Characteristics 2

($T_{amb}=-40^{\circ}\text{C}$ to $+105^{\circ}\text{C}$, voltages are referenced to GND (ground=0V), unless otherwise specified.)

Parameter	Symbol	Conditions	Min.	Typ.	Max.	Unit	
HIGH-level input voltage	V_{IH}	$V_{CC}=1.65\text{V}$ to 1.95V	$0.65 \times V_{CC}$	-	-	V	
		$V_{CC}=2.3\text{V}$ to 2.7V	1.7	-	-	V	
		$V_{CC}=2.7\text{V}$ to 3.6V	2.0	-	-	V	
		$V_{CC}=4.5\text{V}$ to 5.5V	$0.7 \times V_{CC}$	-	-	V	
LOW-level input voltage	V_{IL}	$V_{CC}=1.65\text{V}$ to 1.95V	-	-	$0.35 \times V_{CC}$	V	
		$V_{CC}=2.3\text{V}$ to 2.7V	-	-	0.7	V	
		$V_{CC}=2.7\text{V}$ to 3.6V	-	-	0.8	V	
		$V_{CC}=4.5\text{V}$ to 5.5V	-	-	$0.3 \times V_{CC}$	V	
HIGH-level output voltage	V_{OH}	$V_I = V_{IH}$ or V_{IL}	$I_O=-100\mu\text{A}$; $V_{CC}=1.65\text{V}$ to 5.5V	$V_{CC}-0.1$	-	-	V
			$I_O=-4\text{mA}$; $V_{CC}=1.65\text{V}$	0.95	-	-	V
			$I_O=-8\text{mA}$; $V_{CC}=2.3\text{V}$	1.7	-	-	V
			$I_O=-12\text{mA}$; $V_{CC}=2.7\text{V}$	1.9	-	-	V
			$I_O=-24\text{mA}$; $V_{CC}=3.0\text{V}$	2.0	-	-	V
			$I_O=-32\text{mA}$; $V_{CC}=4.5\text{V}$	3.4	-	-	V
LOW-level output voltage	V_{OL}	$V_I = V_{IH}$ or V_{IL}	$I_O=100\mu\text{A}$; $V_{CC}=1.65\text{V}$ to 5.5V	-	-	0.10	V
			$I_O=4\text{mA}$; $V_{CC}=1.65\text{V}$	-	-	0.70	V
			$I_O=8\text{mA}$; $V_{CC}=2.3\text{V}$	-	-	0.45	V
			$I_O=12\text{mA}$; $V_{CC}=2.7\text{V}$	-	-	0.60	V
			$I_O=24\text{mA}$; $V_{CC}=3.0\text{V}$	-	-	0.80	V
			$I_O=32\text{mA}$; $V_{CC}=4.5\text{V}$	-	-	0.80	V
input leakage current	I_I	$V_I=5.5\text{V}$ or GND; $V_{CC}=0\text{V}$ to 5.5V	-	-	± 1	μA	
OFF-state output current	I_{OZ}	$V_I=V_{IH}$ or V_{IL} ; $V_O=5.5\text{V}$ or GND; $V_{CC}=3.6\text{V}$	-	-	± 2	μA	
power-off leakage current	I_{OFF}	V_I or $V_O=5.5\text{V}$; $V_{CC}=0\text{V}$	-	-	± 2	μA	
supply current	I_{CC}	$V_I=5.5\text{V}$ or GND; $V_{CC}=1.65\text{V}$ to 5.5V ; $I_O=0\text{A}$	-	-	4	μA	
additional supply current	ΔI_{CC}	per pin; $V_I=V_{CC}-0.6\text{V}$; $I_O=0\text{A}$; $V_{CC}=2.3\text{V}$ to 5.5V	-	-	500	μA	

Note: All typical values are measured at $V_{CC}=3.3\text{V}$ and $T_{amb}=25^{\circ}\text{C}$.



3.3.3. AC Characteristics 1

($T_{amb}=-40^{\circ}\text{C}$ to $+85^{\circ}\text{C}$, voltages are referenced to GND (ground=0V), unless otherwise specified.)

Parameter	Symbol	Conditions	Min.	Typ.	Max.	Unit	
nA to nY propagation delay	t_{pd}	see Figure 4	$V_{CC}=1.65\text{V}$ to 1.95V	1.0	3.9	9.8	ns
			$V_{CC}=2.3\text{V}$ to 2.7V	0.5	2.6	4.9	ns
			$V_{CC}=2.7\text{V}$	1.0	2.8	4.7	ns
			$V_{CC}=3.0\text{V}$ to 3.6V	0.5	2.4	4.3	ns
			$V_{CC}=4.5\text{V}$ to 5.5V	0.5	1.9	3.2	ns
nOE to nY enable time	t_{en}	see Figure 5	$V_{CC}=1.65\text{V}$ to 1.95V	1.0	4.1	10.0	ns
			$V_{CC}=2.3\text{V}$ to 2.7V	1.0	2.6	5.0	ns
			$V_{CC}=2.7\text{V}$	1.0	2.8	4.7	ns
			$V_{CC}=3.0\text{V}$ to 3.6V	1.0	2.4	4.1	ns
			$V_{CC}=4.5\text{V}$ to 5.5V	0.5	1.8	3.1	ns
nOE to nY disable time	t_{dis}	see Figure 5	$V_{CC}=1.65\text{V}$ to 1.95V	1.0	3.3	12.6	ns
			$V_{CC}=2.3\text{V}$ to 2.7V	0.5	1.9	5.7	ns
			$V_{CC}=2.7\text{V}$	1.5	3.0	4.8	ns
			$V_{CC}=3.0\text{V}$ to 3.6V	1.0	2.5	4.4	ns
			$V_{CC}=4.5\text{V}$ to 5.5V	0.5	1.8	3.3	ns
Power dissipation capacitance	C_{PD}	per buffer; $V_I = \text{GND}$ to V_{CC}	output enabled	-	17	-	pF
			output disabled	-	5	-	pF

Note:

[1] Typical values are measured at $T_{amb}=25^{\circ}\text{C}$ and $V_{CC}=1.8\text{V}$, 2.5V , 2.7V , 3.3V and 5.0V respectively.

[2] t_{pd} is the same as t_{PLH} and t_{PHL} .

[3] t_{en} is the same as t_{PZH} and t_{PZL} .

[4] t_{dis} is the same as t_{PLZ} and t_{PHZ} .

[3] C_{PD} is used to determine the dynamic power dissipation (P_D in uW).

$$P_D = (C_{PD} \times V_{CC}^2 \times f_i \times N) + \sum (C_L \times V_{CC}^2 \times f_o) \text{ where:}$$

f_i =input frequency in MHz;

f_o =output frequency in MHz;

C_L =output load capacitance in pF;

V_{CC} =supply voltage in V;

N =number of inputs switching;

$\sum (C_L \times V_{CC}^2 \times f_o)$ =sum of outputs.



3.3.4、 AC Characteristics 2

($T_{amb}=-40^{\circ}\text{C}$ to $+105^{\circ}\text{C}$, voltages are referenced to GND (ground=0V), unless otherwise specified.)

Parameter	Symbol	Conditions	Min.	Typ.	Max.	Unit	
nA to nY propagation delay	t_{pd}	see Figure 4	$V_{CC}=1.65\text{V}$ to 1.95V	1.0	-	12.3	ns
			$V_{CC}=2.3\text{V}$ to 2.7V	0.5	-	6.3	ns
			$V_{CC}=2.7\text{V}$	1.0	-	5.9	ns
			$V_{CC}=3.0\text{V}$ to 3.6V	0.5	-	5.4	ns
			$V_{CC}=4.5\text{V}$ to 5.5V	0.5	-	4.0	ns
nOE to nY enable time	t_{en}	see Figure 5	$V_{CC}=1.65\text{V}$ to 1.95V	1.0	-	12.5	ns
			$V_{CC}=2.3\text{V}$ to 2.7V	1.0	-	6.3	ns
			$V_{CC}=2.7\text{V}$	1.0	-	5.9	ns
			$V_{CC}=3.0\text{V}$ to 3.6V	1.0	-	5.1	ns
			$V_{CC}=4.5\text{V}$ to 5.5V	0.5	-	3.9	ns
nOE to nY disable time	t_{dis}	see Figure 5	$V_{CC}=1.65\text{V}$ to 1.95V	1.0	-	15.4	ns
			$V_{CC}=2.3\text{V}$ to 2.7V	0.5	-	7.5	ns
			$V_{CC}=2.7\text{V}$	1.5	-	6.2	ns
			$V_{CC}=3.0\text{V}$ to 3.6V	1.0	-	5.7	ns
			$V_{CC}=4.5\text{V}$ to 5.5V	0.5	-	4.4	ns

Note:

[1] Typical values are measured at $T_{amb}=25^{\circ}\text{C}$ and $V_{CC}=1.8\text{V}$, 2.5V , 2.7V , 3.3V and 5.0V respectively.

[2] t_{pd} is the same as t_{PLH} and t_{PHL} .

[3] t_{en} is the same as t_{PZH} and t_{PZL} .

[4] t_{dis} is the same as t_{PLZ} and t_{PHZ} .

4、 Testing Circuit

4.1、 AC Testing Circuit

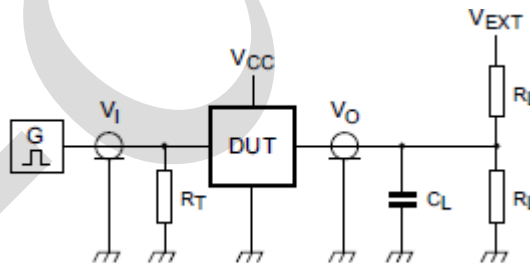

Figure 3. Test circuit for measuring switching times

Definitions for test circuit:

R_L =Load resistance.

C_L =Load capacitance including jig and probe capacitance.

R_T =Termination resistance; should be equal to the output impedance Z_o of the pulse generator.

V_{EXT} =External voltage for measuring switching times.



4.2、 AC Testing Waveforms

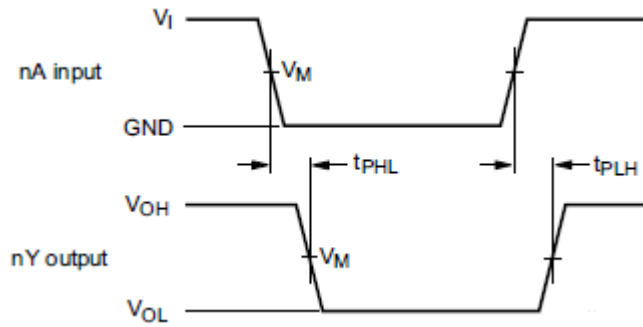

Figure 4. The input (nA) to output (nY) propagation delays

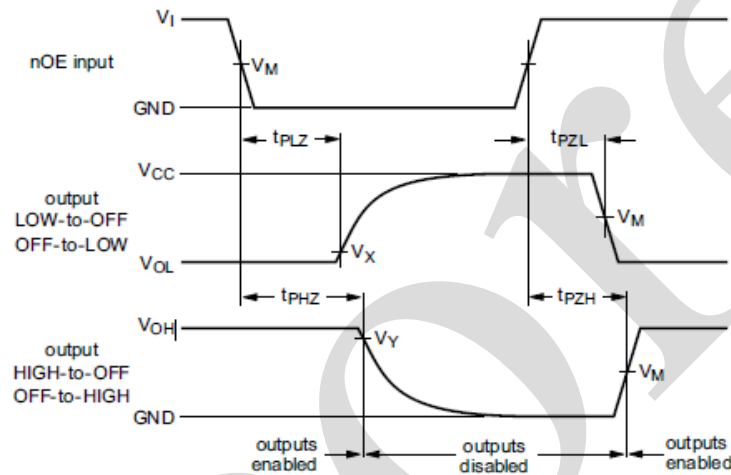

Figure 5. 3-state enable and disable times

4.3、 Measurement Points

Supply voltage	Input	Output		
V_{CC}	V_M	V_M	V_X	V_Y
1.65V to 1.95V	$0.5 \times V_{CC}$	$0.5 \times V_{CC}$	$V_{OL} + 0.15V$	$V_{OH} - 0.15V$
2.3V to 2.7V	$0.5 \times V_{CC}$	$0.5 \times V_{CC}$	$V_{OL} + 0.15V$	$V_{OH} - 0.15V$
2.7V	1.5V	1.5V	$V_{OL} + 0.3V$	$V_{OH} - 0.3V$
3.0V to 3.6V	1.5V	1.5V	$V_{OL} + 0.3V$	$V_{OH} - 0.3V$
4.5V to 5.5V	$0.5 \times V_{CC}$	$0.5 \times V_{CC}$	$V_{OL} + 0.3V$	$V_{OH} - 0.3V$

4.4、 Test Data

Supply voltage	Input		Load		V_{EXT}		
V_{CC}	V_I	$t_r = t_f$	C_L	R_L	t_{PLH}, t_{PHL}	t_{PZH}, t_{PHZ}	t_{PZL}, t_{PLZ}
1.65V to 1.95V	V_{CC}	$\leq 2.0ns$	30pF	1k Ω	open	GND	$2 \times V_{CC}$
2.3V to 2.7V	V_{CC}	$\leq 2.0ns$	30pF	500 Ω	open	GND	$2 \times V_{CC}$
2.7V	2.7V	$\leq 2.5ns$	50pF	500 Ω	open	GND	6V
3.0V to 3.6V	2.7V	$\leq 2.5ns$	50pF	500 Ω	open	GND	6V
4.5V to 5.5V	V_{CC}	$\leq 2.5ns$	50pF	500 Ω	open	GND	$2 \times V_{CC}$



5、 Package Information

5.1、 TSSOP8

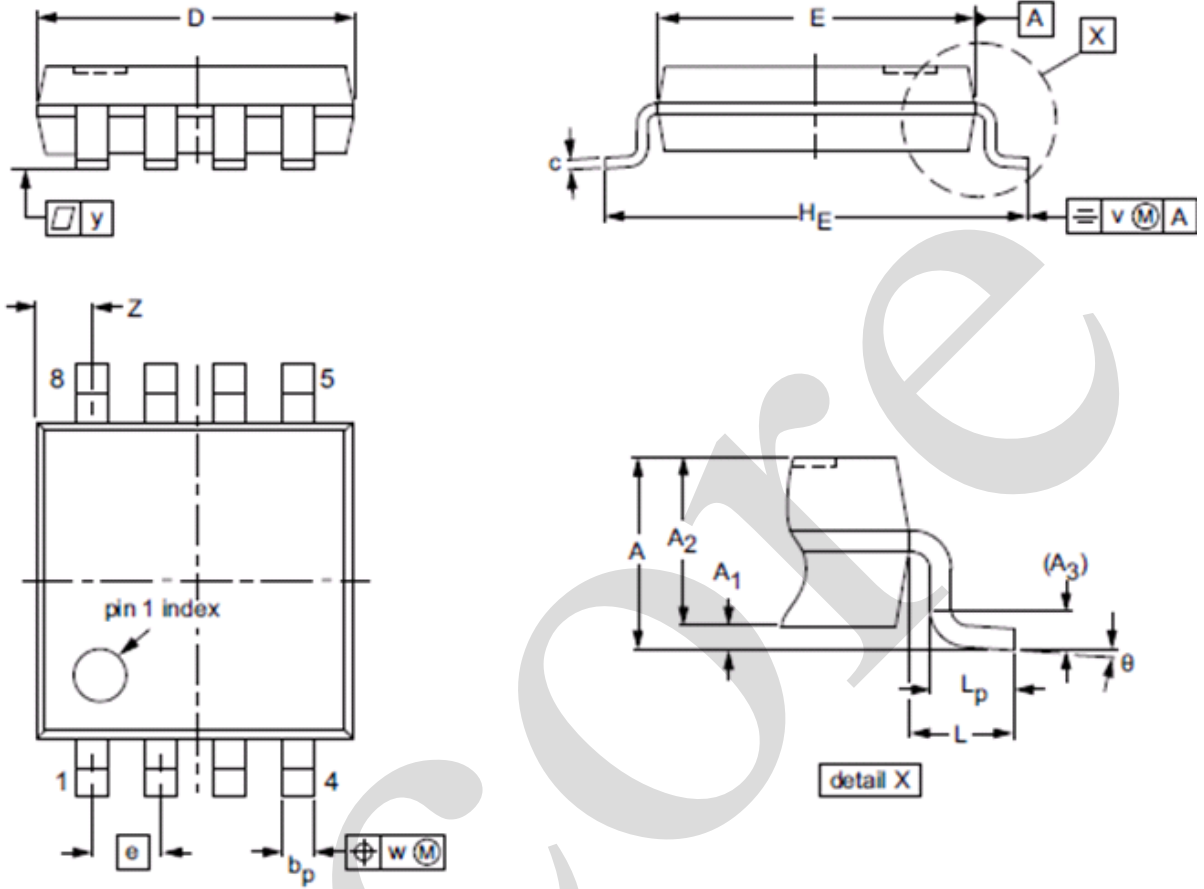

UNIT	A max.	A ₁	A ₂	A ₃	b _p	c	D ⁽¹⁾	E ⁽¹⁾	e	H _E	L	L _p	v	w	y	Z ⁽¹⁾	θ
mm	1.1	0.15 0.00	0.95 0.75	0.25	0.38 0.22	0.18 0.08	3.1 2.9	3.1 2.9	0.65	4.1 3.9	0.5	0.47 0.33	0.2	0.13	0.1	0.70 0.35	8° 0°



5.2. VSSOP8

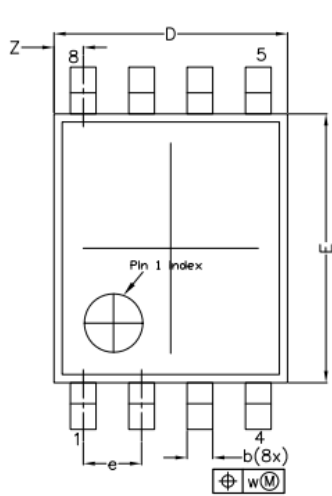

TOP VIEW

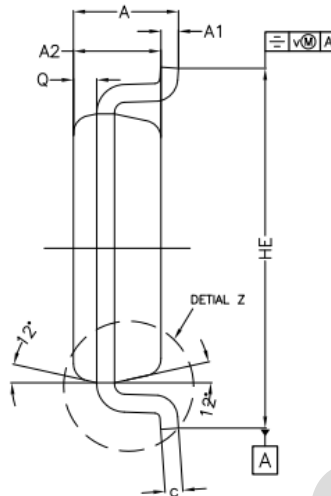

SIDE VIEW

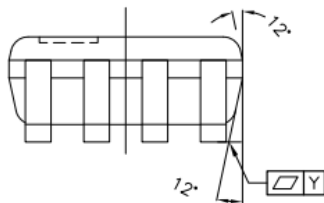

SIDE VIEW

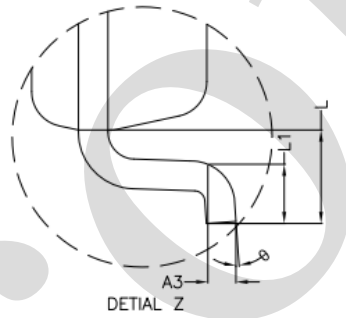

DETAIL Z

* CONTROLLING DIMENSION : MM

SYMBOL	MILLIMETER		
	MIN.	NOM.	MAX.
A	---	---	1.00
A1	0.00	---	0.15
A2	0.60	0.75	0.85
A3	---	0.12	---
Q	0.19	0.20	0.21
b	0.17	0.22	0.27
c	0.08	---	0.23
D	1.90	2.00	2.10
E	2.20	2.30	2.40
HE	3.00	3.10	3.20
e	0.50 bsc		
L	0.40 bsc		
L1	0.15	---	0.40
Y	---	0.10	---
v	---	0.20	---
w	---	0.08	---
Z	0.10	---	0.40
θ	0°	---	8°

NOTES

1.0 COPLANARITY APPLIES TO LEADS, CORNER LEADS AND DIE ATTACH PAD.



6、 Statements And Notes

6.1、 The name and content of Hazardous substances or Elements in the product

Part name	Hazardous substances or Elements									
	Lead and lead compounds	Mercury and mercury compounds	Cadmium and cadmium compounds	Hexavalent chromium compounds	Polybrominated biphenyls	Polybrominated biphenyl ethers	Dibutyl phthalate	Butylbenzyl phthalate	Di-2-ethylhexyl phthalate	Diisobutyl phthalate
Lead frame	○	○	○	○	○	○	○	○	○	○
Plastic resin	○	○	○	○	○	○	○	○	○	○
Chip	○	○	○	○	○	○	○	○	○	○
The lead	○	○	○	○	○	○	○	○	○	○
Plastic sheet installed	○	○	○	○	○	○	○	○	○	○
explanation	○: Indicates that the content of hazardous substances or elements in the detection limit of the following the SJ/T11363-2006 standard. ×: Indicates that the content of hazardous substances or elements exceeding the SJ/T11363-2006 Standard limit requirements.									

6.2、 Notion

Recommended carefully reading this information before the use of this product;

The information in this document are subject to change without notice;

This information is using to the reference only, the company is not responsible for any loss;

The company is not responsible for the any infringement of the third party patents or other rights of the responsibility.