



Infrared
Product Data Sheet
LTR-4206

Spec No. :DS-50-92-0072
Effective Date: 09/14/2019
Revision: E

LITE-ON DCC

RELEASE

BNS-OD-FC001/A4

Detector LTR-4206

1. Description

LTR-4206 series is a high radiant sensitivity silicon NPN phototransistor. It is molded in water clear T1 package. It has wide range of spectral detecting wavelength range and has peak spectral sensitivity at 900nm. It is suitable to be used in pair with IR emitter and visible light.

1.1. Features

- Lead (Pb) free product and RoHS compliant.
- Wide range of collector current
- Popular T-1 Ø3mm diameter.
- Water clear lens

1.2. Applications

- Sensor

2. Outline Dimensions

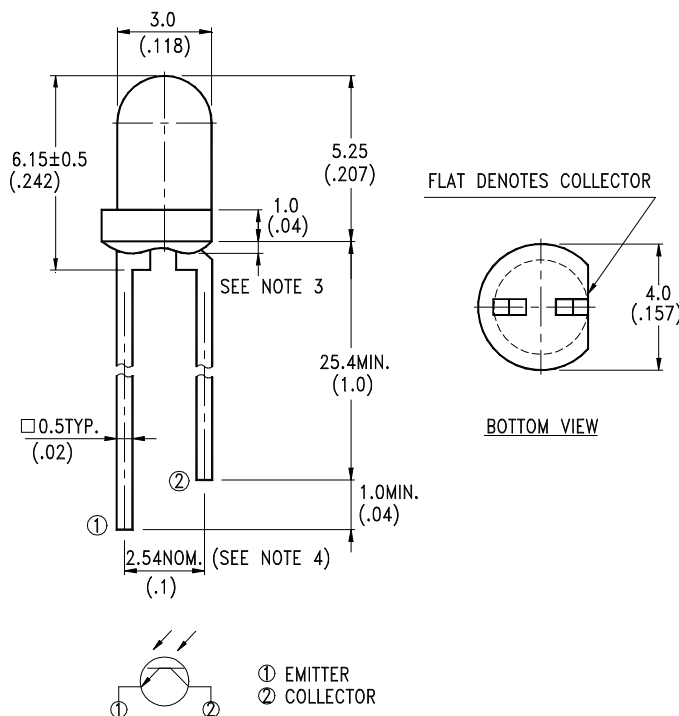

Notes :

1. All dimensions are in millimeters (inches).
2. Tolerance is $\pm 0.25\text{mm}$ (.010") unless otherwise noted.
3. Protruded resin under flange is 0.5mm (.020") max.
4. Lead spacing is measured where the leads emerge from the package.

Detector LTR-4206

3. Absolute Maximum Ratings at TA=25°C

Parameter	Maximum Rating	Unit
Power Dissipation	100	mW
Collector-Emitter Voltage	30	V
Emitter-Collector Voltage	5	V
Operating Temperature Range	-40°C to + 85°C	
Storage Temperature/Humidity Range	-55°C to + 100°C	
Lead Soldering Temperature [2.0mm (.787") From Body	260°C for 5 Seconds	

4. Electrical / Optical Characteristics at TA=25°C

Parameter	Symbol	Min.	Typ.	Max.	Unit	Test Condition	BIN No
Collector-Emitter Breakdown Voltage	$V_{(BR)CEO}$	30			V	$I_C = 1\text{mA}$ $E_e = 0\text{mW/cm}^2$	
Emitter-Collector Breakdown Voltage	$V_{(BR)ECO}$	5			V	$I_E = 100\mu\text{A}$ $E_e = 0\text{mW/cm}^2$	
Collector Emitter Saturation Voltage	$V_{CE(SAT)}$			0.4	V	$I_C = 0.5\text{mA}$ $E_e = 1\text{mW/cm}^2$	
Rise Time	T_r		10		μs	$V_{CC} = 5\text{V}$ $I_C = 1\text{mA}$	
Fall Time	T_f		10		μs	$R_L = 1\text{K}\Omega$	
Collector Dark Current	I_{CEO}			100	nA	$V_{CE} = 10\text{V}$ $E_e = 0\text{mW/cm}^2$	
On State Collector Current *See Note(1)	$I_{C(ON)}$	0.8		2.4	mA	$V_{CE} = 5\text{V}$ $E_e = 1\text{mW/cm}^2$ $\lambda = 940\text{nm}$	BIN C
		1.6		4.8			BIN D
		3.2		9.6			BIN E
		6.4					BIN F

Note: 1. The tolerance of On State Collector Current (I_{con}) is $\pm 10\%$.

5. Typical Electrical / Optical Characteristics Curves

(25°C Ambient Temperature Unless Otherwise Noted)

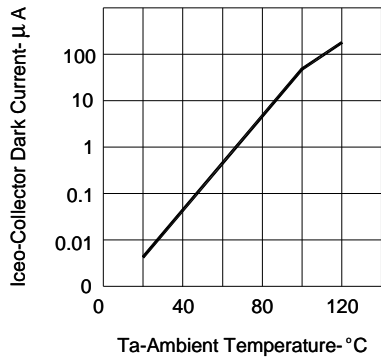

FIG.1 COLLECTOR DARK CURRENT VS AMBIENT TEMPERATURE

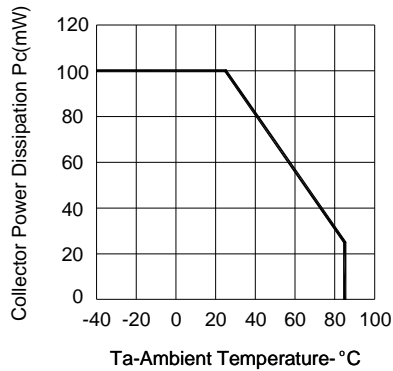

FIG.2 COLLECTOR POWER DISSIPATION VS AMBIENT TEMPERATURE

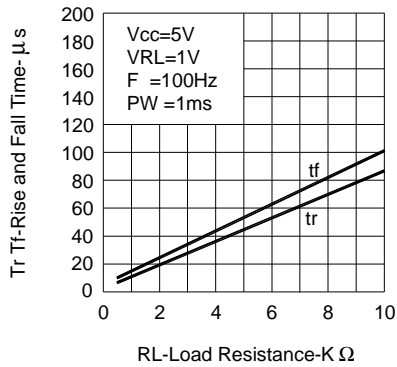

FIG.3 RISE AND FALL TIME VS LOAD RESISTANCE

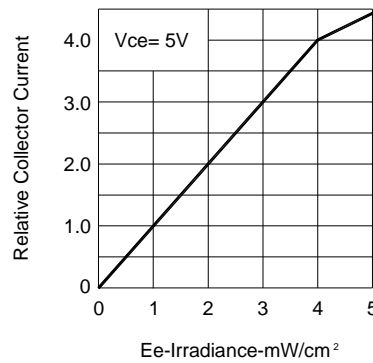

FIG.4 RELATIVE COLLECTOR CURRENT VS IRRADIANCE

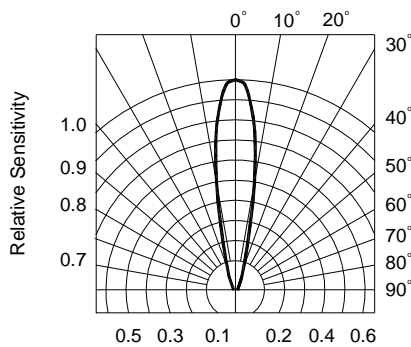

FIG.5 SENSITIVITY DIAGRAM

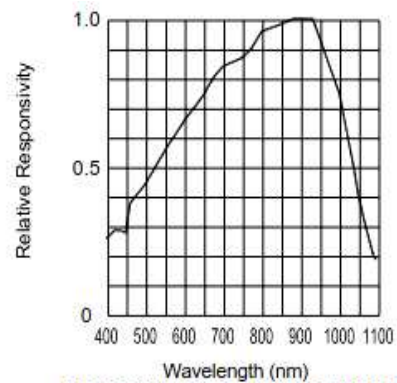

FIG.6 SPECTRAL DISTRIBUTION

6. Recommended Solder Pad and Soldering Profile

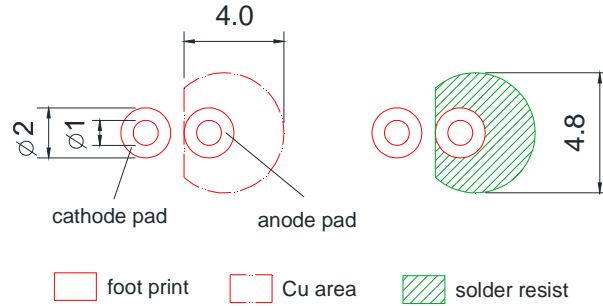

FIG.8 RECOMMENDED SOLDER PAD

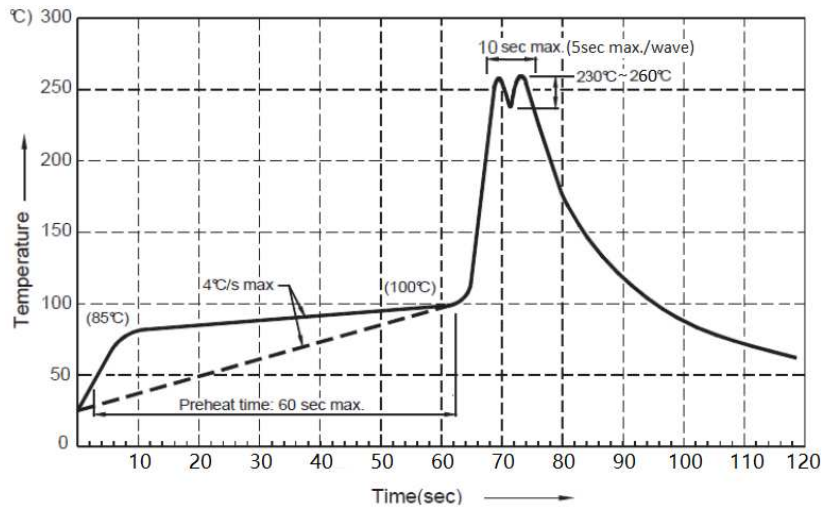

FIG.9 RECOMMENDED LEAD FRAME WAVE SOLDERING PROFILE