



200V 1A Half Bridge Driver

General description:

The XJNG2102 is a high voltage, high speed power MOSFET drivers with dependent high- and low-side referenced output channels. Proprietary HVIC and latch immune CMOS technologies enable ruggedized monolithic construction. The logic input is compatible with standard CMOS or LSTTL output, down to 3.3 V logic. The output drivers feature a high pulse current buffer stage designed for minimum driver cross-conduction. The floating channel can be used to drive an N-channel power MOSFET in the high-side configuration which operates up to 200 V.

Features:

- Floating channel designed for bootstrap operation
- Fully operational to +200 V
- Tolerant to negative transient voltage, dV/dt immune
- Gate drive supply range from 6 V to 18 V
- 3.3 V input logic compatible
- Typically output Source/Sink current capability 1A/1A

Package top view



SOIC-8

Application

- Switch Mode Power Supplies (SMPS)
- Small and medium- power motor driver
- Power MOSFET driver
- Half / Full-Bridge Power Converters
- Any Complementary Drive Converters

Package Marking and Ordering Information

Device	Order code	Device Package	Device Marking
XJNG2102	XJNG2102	SOIC8	XJNG2102

Typical Application Circuit

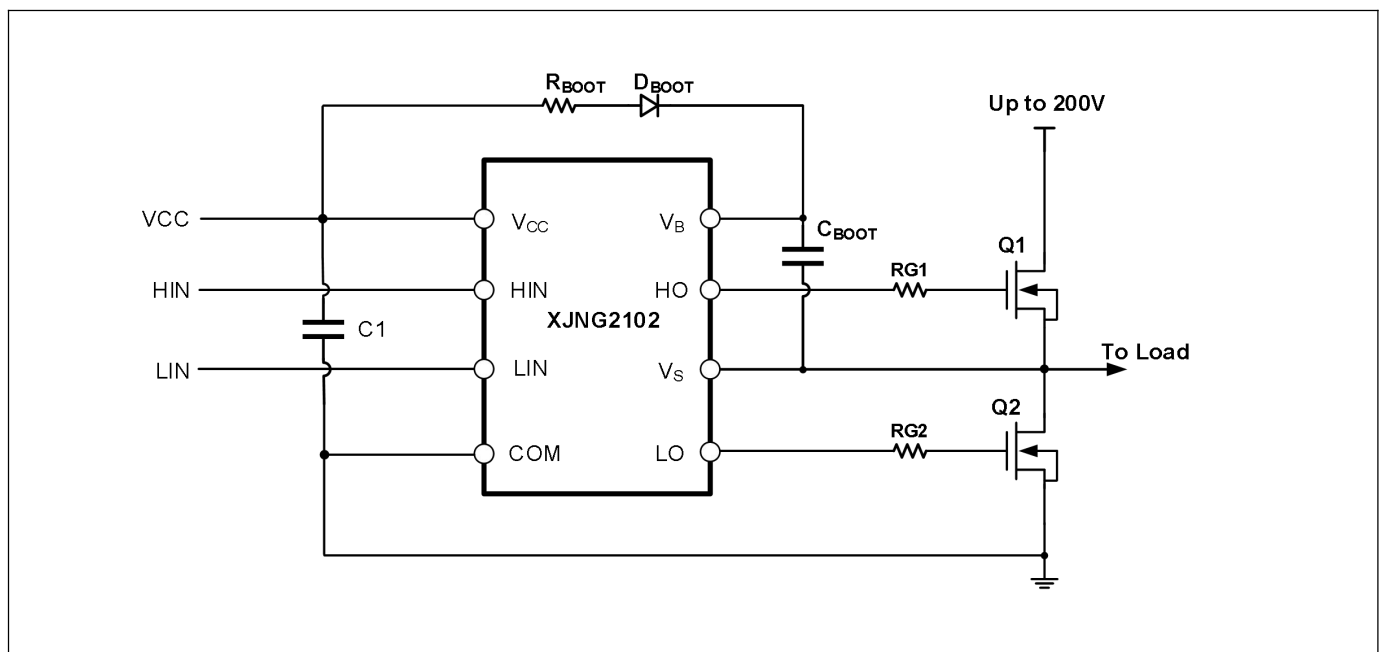



Maximum Ratings

Absolute maximum ratings indicate sustained limits beyond which damage to the device may occur. All voltage parameters are absolute voltages referenced to COM. The thermal resistance and power dissipation ratings are measured under board mounted and still air conditions.

Symbol	Definition	Min.	Max.	Units
V _B	High side floating supply	-0.3	225	V
V _S	High side floating supply return	V _B - 25	V _B + 0.3	V
V _{HO}	High side gate drive output	V _S - 0.3	V _B + 0.3	V
V _{CC}	Low side and main power supply	-0.3	25	V
V _{LO}	Low side gate drive output	-0.3	V _{CC} + 0.3	V
V _{IN}	Logic input of HIN & LIN	-0.3	V _{CC} + 0.3	V
dV _S /dt	Allowable offset supply voltage transient	—	50	V/ns
P _D	Package Power Dissipation @ TA ≤ 25°C (SOIC-8)	—	0.625	W
R _{thJA}	Thermal Resistance Junction to Ambient (SOIC-8)	—	200	°C/W
T _J	Junction Temperature	—	150	°C
T _S	Storage Temperature	-55	150	°C
T _L	Lead Temperature (Soldering, 10 seconds)	—	300	°C
ESD	HBM Model	1500	—	V
	CDM Model	500	—	V

Recommended Operating Conditions

For proper operation the device should be used within the recommended conditions. The V_S offset rating is tested with all supplies biased at a 15 V differential

Symbol	Definition	Min.	Max.	Units
V _B	High side floating supply	V _S + 6	V _S + 20	V
V _S	High side floating supply return	-6	200	V
V _{HO}	High side gate drive output	V _S	V _B	V
V _{CC}	Low side and main power supply	6	20	V
V _{LO}	Low side gate drive output	0	V _{CC}	V
V _{IN}	Logic input of HIN & LIN	0	V _{CC}	V
T _A	Ambient temperature	-40	125	°C

Dynamic Electrical Characteristics

VBIAS (V_{CC}, V_B) = 15V, C_L = 1000 pF and T_A = 25°C unless otherwise specified

Symbol	Definition	Min.	Typ.	Max.	Units
t _{ON}	Turn on propagation delay	—	150	250	ns
t _{OFF}	Turn off propagation delay	—	140	250	ns
MT	Delay matching time (t _{ON} , t _{OFF})	—	--	50	ns
DT	Dead time	—	200	--	ns
t _R	Turn on rising time	—	50	100	ns
t _F	Turn off falling time	—	40	100	ns



Static Electrical Characteristics

VBIAS (VCC, VBS) = 15V, CL = 1000 pF and TA = 25°C unless otherwise specified.

Symbol	Definition	Min.	Typ.	Max.	Units
V _{IH}	High level input threshold voltage	2.5	—	—	V
V _{IL}	Low level input threshold voltage	—	—	0.8	V
V _{OH}	High level output voltage drop, V _{BIAS} - V _O	—	—	0.2	V
V _{OL}	Low level output voltage drop, V _O	—	—	0.1	V
I _{LK}	High-side floating supply leakage current	—	—	1	μA
I _{QBS}	Quiescent V _{BS} supply current	—	40	120	μA
I _{QCC}	Quiescent V _{CC} supply current	—	160	280	μA
I _{IN+}	Logic “1” input bias current (HIN “1” & LIN “1”)	—	10	20	μA
I _{IN-}	Logic “0” input bias current (HIN “0” & LIN “0”)	—	—	1	μA
V _{CCUV+}	VCC supply undervoltage positive going threshold	—	5.5	—	V
V _{CCUV-}	VCC supply undervoltage negative going threshold	—	5.0	—	V
I _{O+}	Output High short circuit pulsed current	—	1	—	A
I _{O-}	Output low short circuit pulsed current	—	1	—	A

Function Block Diagram

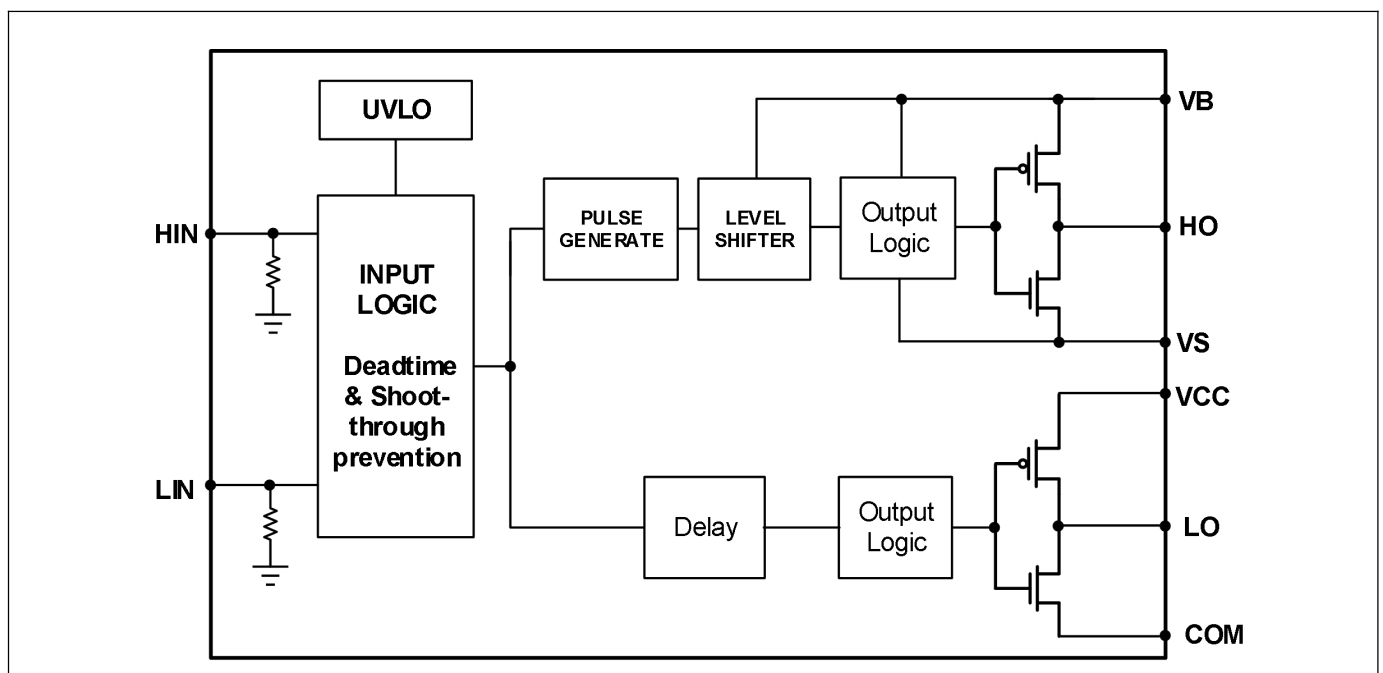



Pin Configuration

Pin No.	Pin Name	Pin Function
1	V _{CC}	Low side and main power supply
2	HIN	Logic input for high side gate driver output (HO)
3	LIN	Logic input for low side gate driver output (LO)
4	COM	Ground
5	LO	Low side gate drive output, out of phase with LIN
6	V _s	High side floating supply return or bootstrap return
7	HO	High side gate drive output, in phase with HIN
8	V _B	High side floating supply

Function Timing Diagram

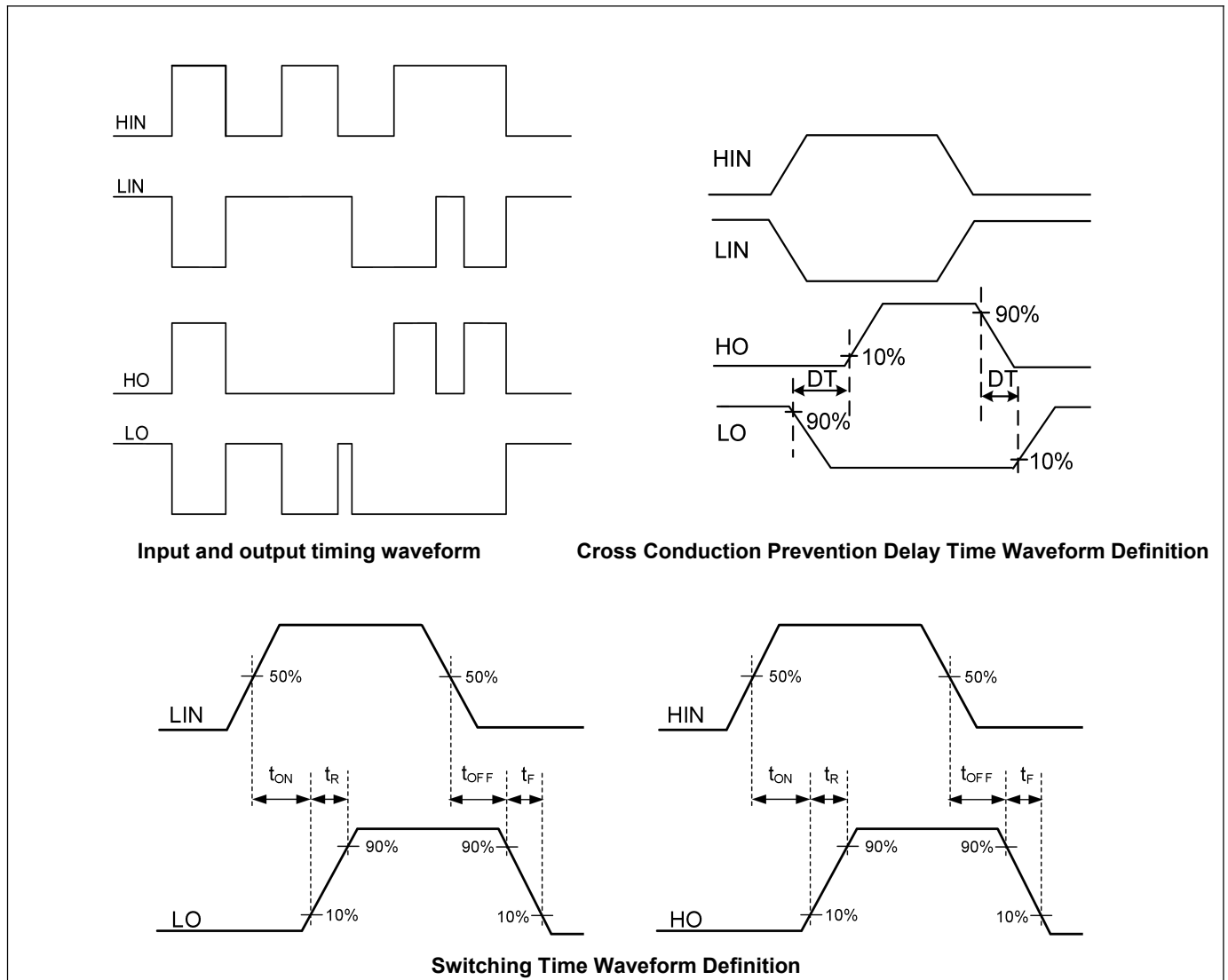



Package Information

SOIC-8 Package Dimensions

Size Symbol	MIN(mm)	TYP(mm)	MAX(mm)	Size Symbol	MIN(mm)	TYP(mm)	MAX(mm)
A	-	-	1.75	D	4.70	4.90	5.10
A1	0.10	-	0.225	E	5.80	6.00	6.20
A2	1.30	1.40	1.50	E1	3.70	3.90	4.10
A3	0.60	0.65	0.70	e	1.27BSC		
b	0.39	-	0.48	h	0.25	-	0.50
b1	0.38	0.41	0.43	L	0.50	-	0.80
c	0.21	-	0.26	L1	1.05BSC		
c1	0.19	0.20	0.21	θ	0	-	8°

SOIC-8 Package Outlines

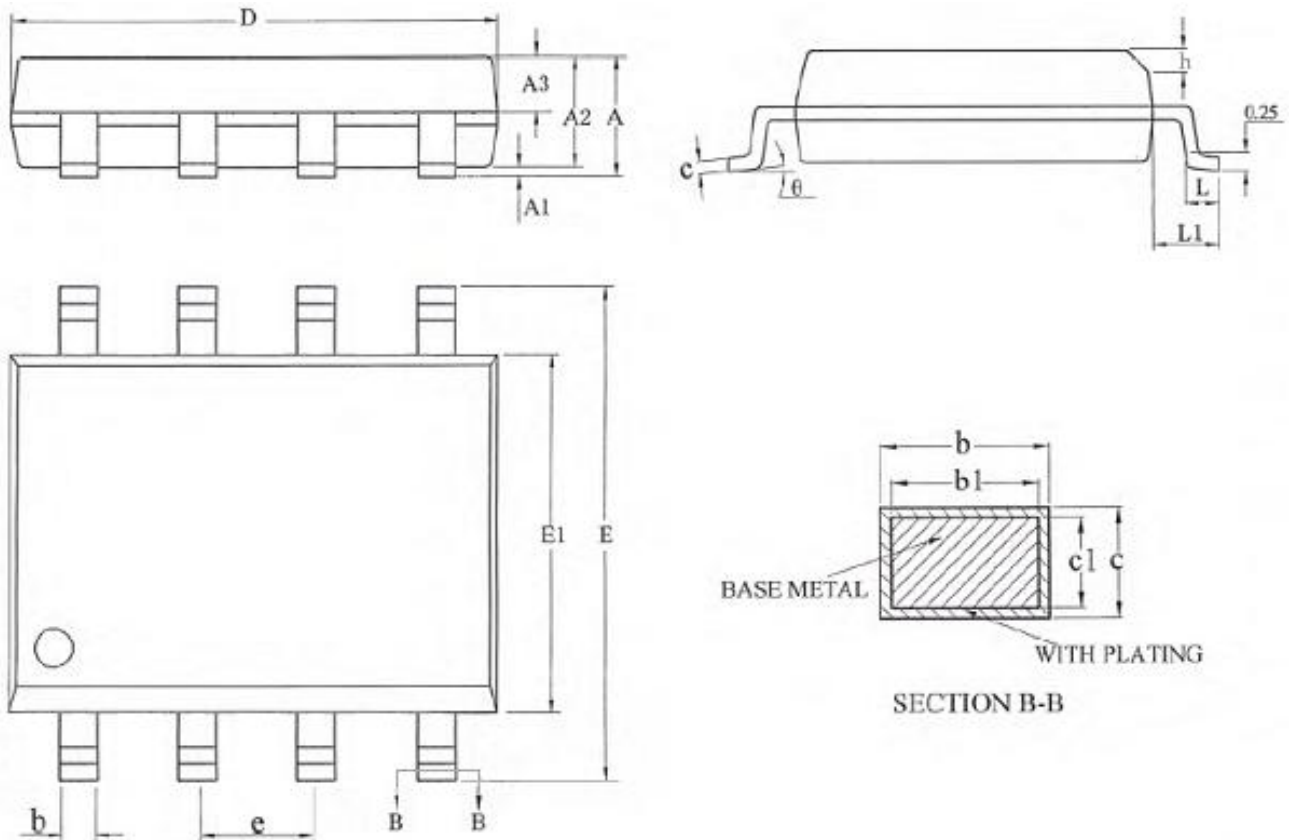



Attention:

- Any and all NCE power products described or contained herein do not have specifications that can handle applications that require extremely high levels of reliability, such as life-support systems, aircraft's control systems, or other applications whose failure can be reasonably expected to result in serious physical and/or material damage. Consult with your NCE power representative nearest you before using any NCE power products described or contained herein in such applications.
- NCE power assumes no responsibility for equipment failures that result from using products at values that exceed, even momentarily, rated values (such as maximum ratings, operating condition ranges, or other parameters) listed in products specifications of any and all NCE power products described or contained herein.
- Specifications of any and all NCE power products described or contained herein stipulate the performance, characteristics, and functions of the described products in the independent state, and are not guarantees of the performance, characteristics, and functions of the described products as mounted in the customer's products or equipment. To verify symptoms and states that cannot be evaluated in an independent device, the customer should always evaluate and test devices mounted in the customer's products or equipment.
- NCE power Semiconductor CO.,LTD. strives to supply high-quality high-reliability products. However, any and all semiconductor products fail with some probability. It is possible that these probabilistic failures could give rise to accidents or events that could endanger human lives, that could give rise to smoke or fire, or that could cause damage to other property. When designing equipment, adopt safety measures so that these kinds of accidents or events cannot occur. Such measures include but are not limited to protective circuits and error prevention circuits for safe design, redundant design, and structural design.
- In the event that any or all NCE power products(including technical data, services) described or contained herein are controlled under any of applicable local export control laws and regulations, such products must not be exported without obtaining the export license from the authorities concerned in accordance with the above law.
- No part of this publication may be reproduced or transmitted in any form or by any means, electronic or mechanical, including photocopying and recording, or any information storage or retrieval system, or otherwise, without the prior written permission of NCE power Semiconductor CO.,LTD.
- Information (including circuit diagrams and circuit parameters) herein is for example only ; it is not guaranteed for volume production. NCE power believes information herein is accurate and reliable, but no guarantees are made or implied regarding its use or any infringements of intellectual property rights or other rights of third parties.
- Any and all information described or contained herein are subject to change without notice due to product/technology improvement, etc. When designing equipment, refer to the "Delivery Specification" for the NCE power product that you intend to use.
- This catalog provides information as of Sep.2010. Specifications and information herein are subject to change without notice.