

THIS DRAWING IS UNPUBLISHED. RELEASED FOR PUBLICATION  
 © COPYRIGHT BY TYCO ELECTRONICS CORPORATION. ALL RIGHTS RESERVED.

LOC	DIST	REVISIONS			
P	LTR	DESCRIPTION	DATE	DWN	APVD
AF	50				
	E	REVISED PER OG3A-0770-02	17JAN03	MF	GP
	F	ECR-13-004361	05AUG13	XJ	DZ

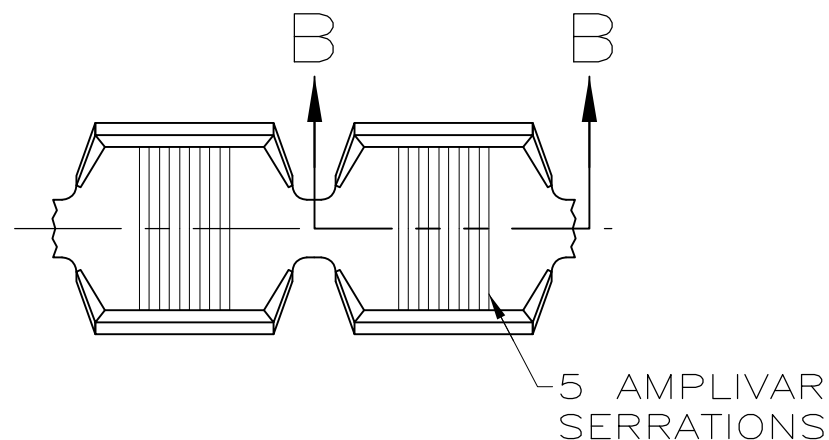

- 1 CONTINUOUS STRIP ON REELS
- 2 CRIMP WIDTH: .180 F TYPE (AMPLIVAR THRU)  
 CRIMP HEIGHT ( $\pm 0.002$ ) = (TOTAL CMA + 23,000) / 312,500  
 GENERAL APPLICATION GUIDELINES MUST BE FOLLOWED AS SPECIFIED IN CATALOG #82221  
 FOR APPLICATOR INFORMATION CALL: 1-800-722-1111  
 FOR PRODUCT INFORMATION CALL: 1-800-522-6752

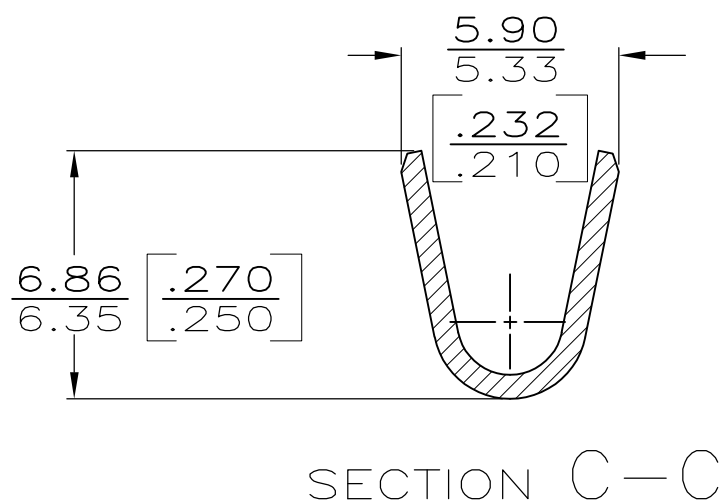
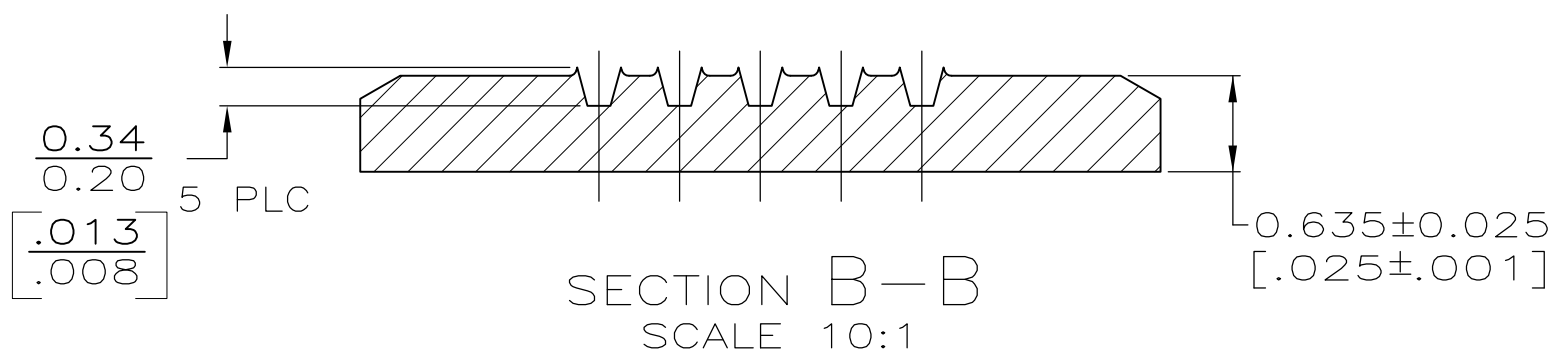
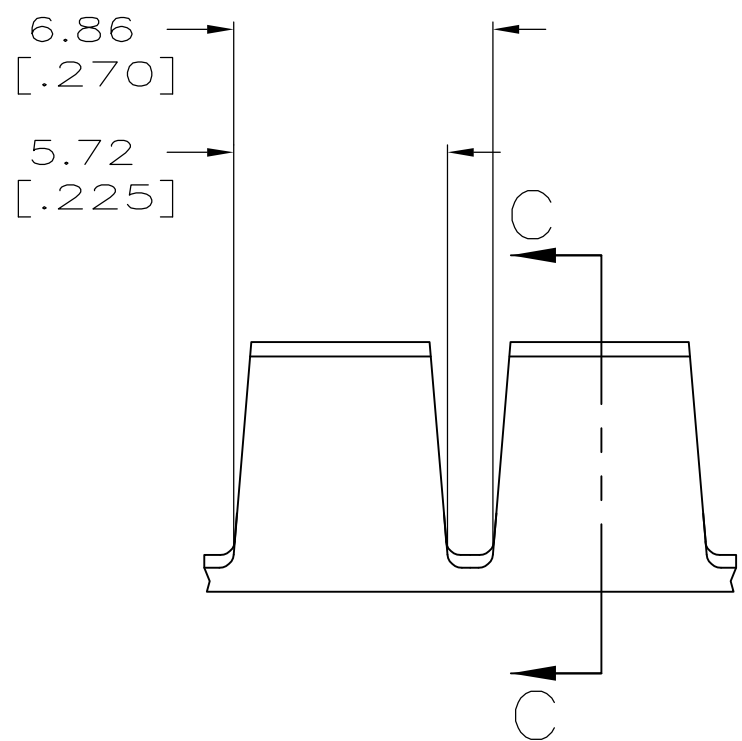

THIS DRAWING IS A CONTROLLED DOCUMENT.

DIMENSIONS:	TOLERANCES UNLESS OTHERWISE SPECIFIED:
mm [INCHES]	"
	0 PLC ± -
	1 PLC ± -
	2 PLC ± -
	3 PLC ± 0.38 [.015]
	4 PLC ANGLES ± -
MATERIAL	FINISH
BRASS	-

DWN	P FORTNEY	11/27/89
CHK	MS FEHER	11/29/89
APVD	D.SCHWENK	11/29/89
PRODUCT SPEC	-	-
APPLICATION SPEC	114-2009	-
WEIGHT	-	-

7000-13000 CMA		41770	
WIRE SIZE		PART NUMBER	
Tyco Electronics Corporation Harrisburg, PA 17105-3608			
NAME SPLICE, AMPLIVAR			
SIZE	CAGE CODE	DRAWING NO	RESTRICTED TO
A3	00779	C-41770	-
CUSTOMER DRAWING		SCALE 5:1	SHEET 1 OF 1 REV F