

REVISIONS					
P	LTR	DESCRIPTION	DATE	DWN	APVD
	A1	REDRAWN TO CREO	13APR2017	JJH	JP

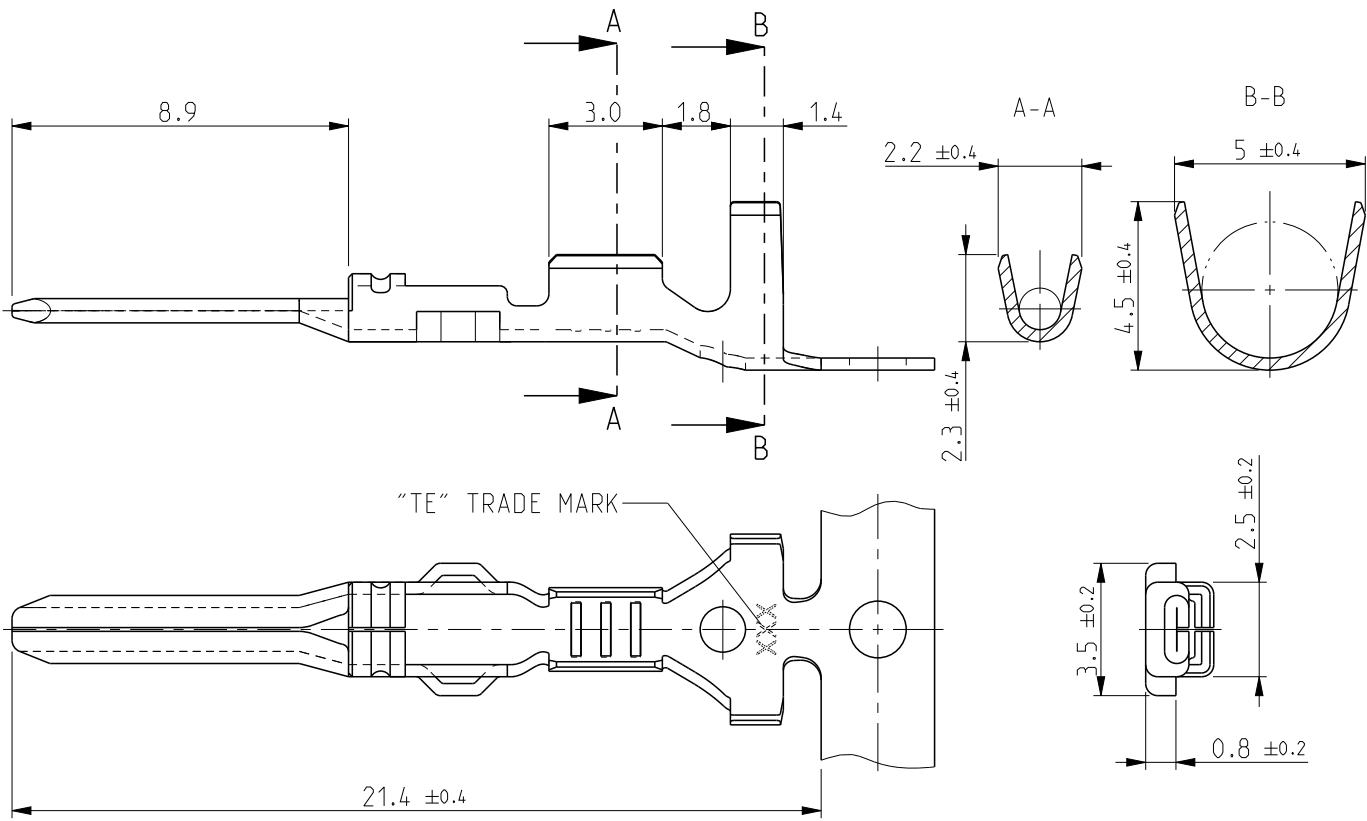

1. DELIVERY STATE: WRAPPED UP ROLL WITH STEP BETWEEN TERMINALS = 11.9±0.2mm
 STATO DI FORNITURA: AVVOLTI SU BOBINA CON PASSO TRA TERMINALI DI = 11.9±0.2mm

2. SUITABLE FOR SINGLE WIRE SEAL TE PN 828904-1
 ADDETTO PER GOMMINO TE 828904-1

CUSTOMER DRAWING FOR INFORMATION ONLY
 DISEGNO PER CLIENTE SOLO PER RIFERIMENTO

INS. DIA. RANGE (DIAM. ISOLANTE)	WIRE RANGE (RANGO FILO)
2	0.3 - 0.5mm ²

PRE-TIN (PRE-STAGNATO)	BRASS (OTTONE)	282226-1
FINISH/COLOUR (FINITURE/COLORE)	MATERIAL (MATERIALE)	PART NUMBER

DIMENSIONS: mm	DWN D. CHIACCHIO	12MAY1993	MATERIAL	-	FINISH	-												
	CHK G. VIGNOLI	13MAY1993	TE TE Connectivity															
TOLERANCES UNLESS OTHERWISE SPECIFIED: <table border="1" style="font-size: small;"> <tr><td>6 PLC</td><td>±</td></tr> <tr><td>1 PLC</td><td>±</td></tr> <tr><td>2 PLC</td><td>±</td></tr> <tr><td>3 PLC</td><td>±</td></tr> <tr><td>4 PLC</td><td>±</td></tr> </table> <table border="1" style="font-size: small;"> <tr><td>ANGLES</td><td>±2°</td></tr> </table>	6 PLC	±	1 PLC	±	2 PLC	±	3 PLC	±	4 PLC	±	ANGLES	±2°	PRODUCT SPEC 108-20125	NAME TAB CONTACT .070 TYPE	SIZE A 4	CAGE CODE -	DRAWING NO C=282226	RESTRICTED TO -
	6 PLC	±																
1 PLC	±																	
2 PLC	±																	
3 PLC	±																	
4 PLC	±																	
ANGLES	±2°																	
APVD -	APPLICATION SPEC 114-20067	WEIGHT -	CUSTOMER DRAWING				SCALE 5:1	SHEET 1 OF 1	REV A1									

THIS DRAWING IS UNPUBLISHED. ALL RIGHTS RESERVED. © COPYRIGHT copyright_date BY -