

1
Kodierung A
CODING A

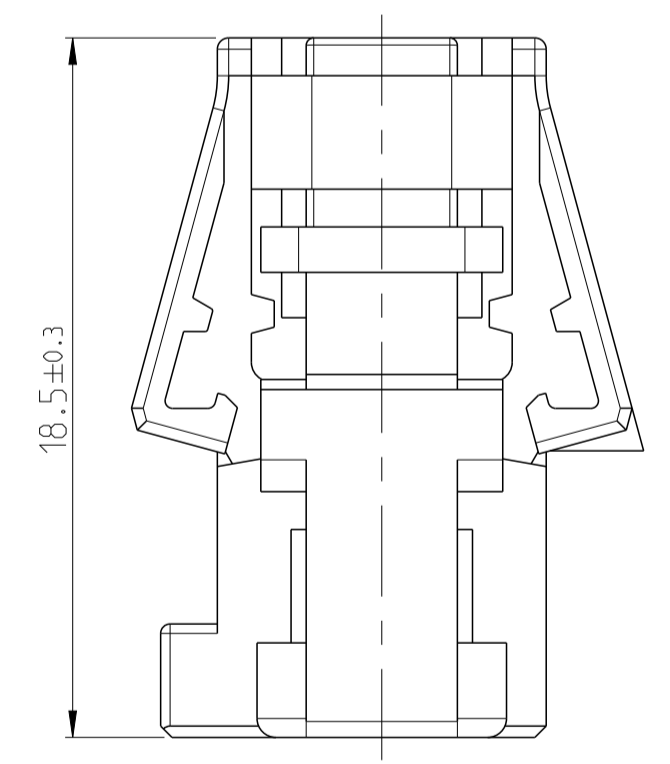

2
Kodierung B
CODING B

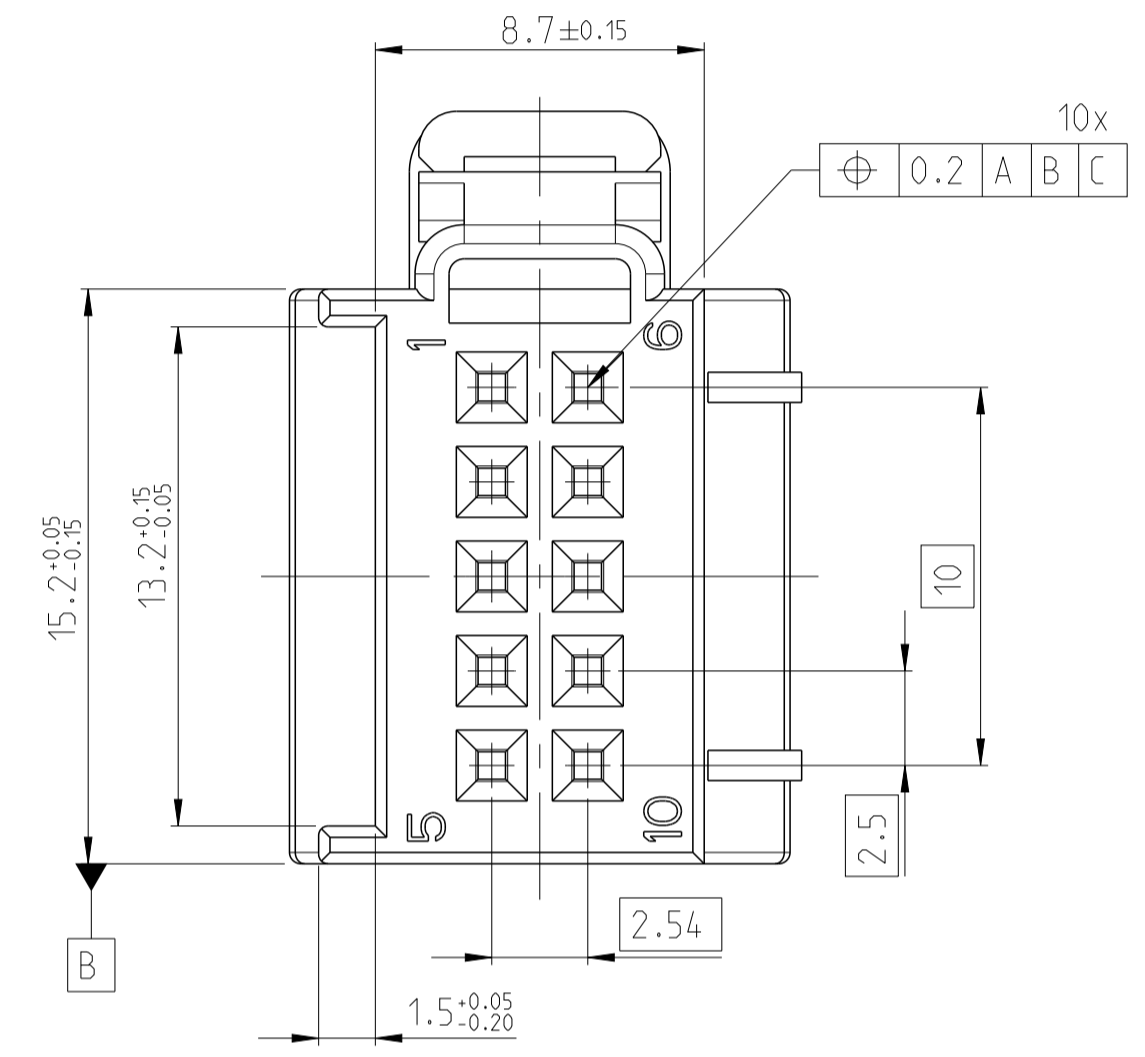
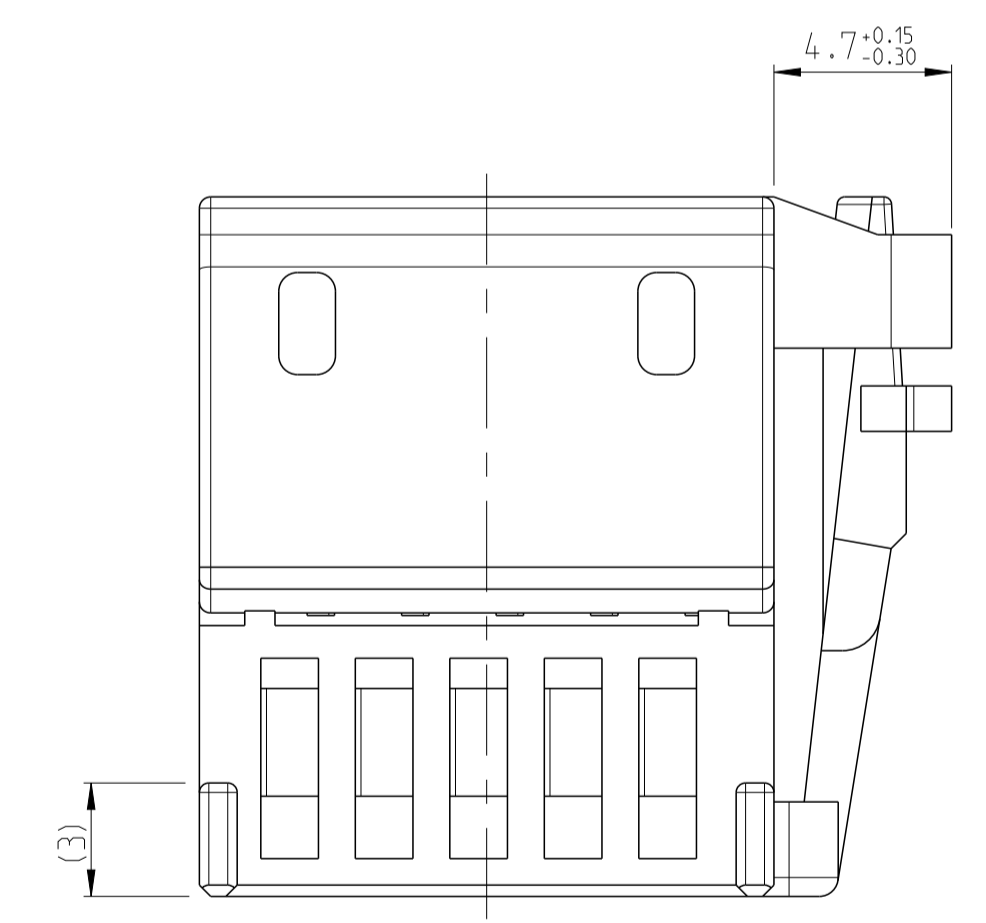
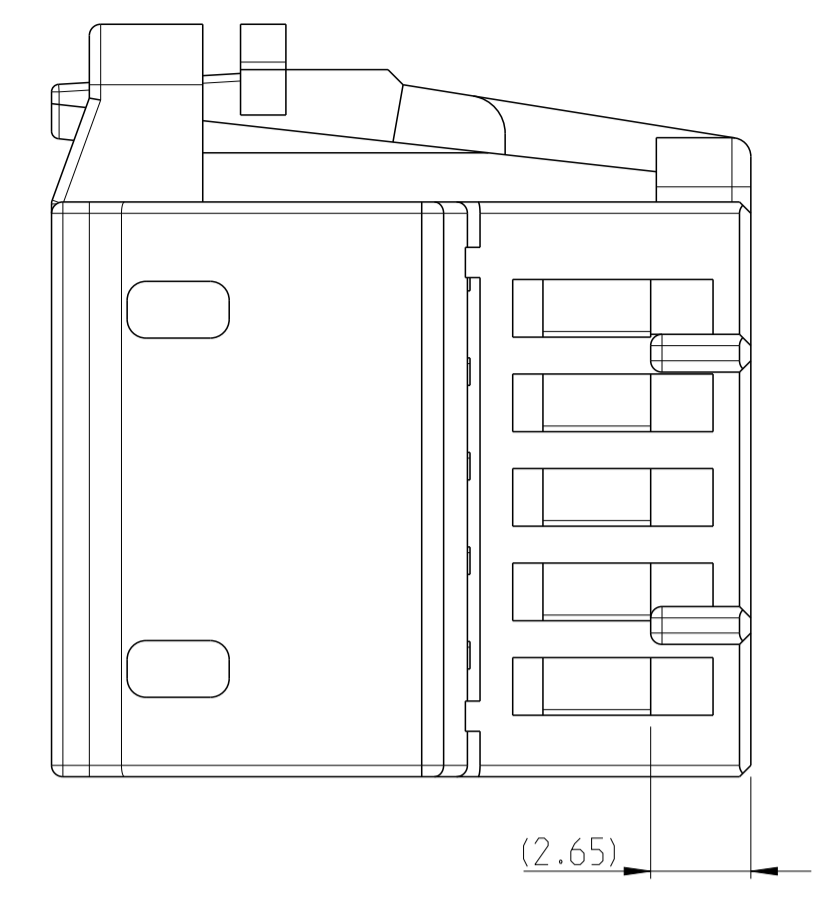
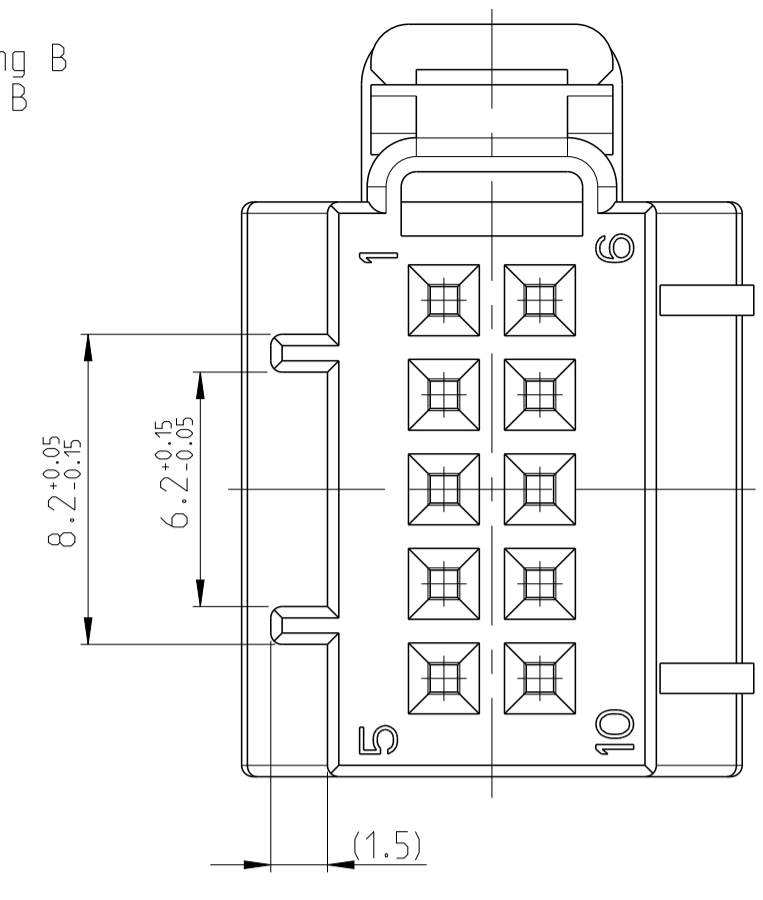

LOC	DIST	REVISIONS				
A1		REV.	DESCRIPTION	DATE	DWN	APVD
-		A	New Drawing	17AUG2012	MR	RBT
-		A1	SLOTS IN THE FLIP SEC. LOCK ADDED	27MAR2013	MR	RBT
-		A2	1-1670990-4 added	13JUN2017	KS	MZ

Deckel geschlossen dargestellt
COVER CLOSED PICTURED

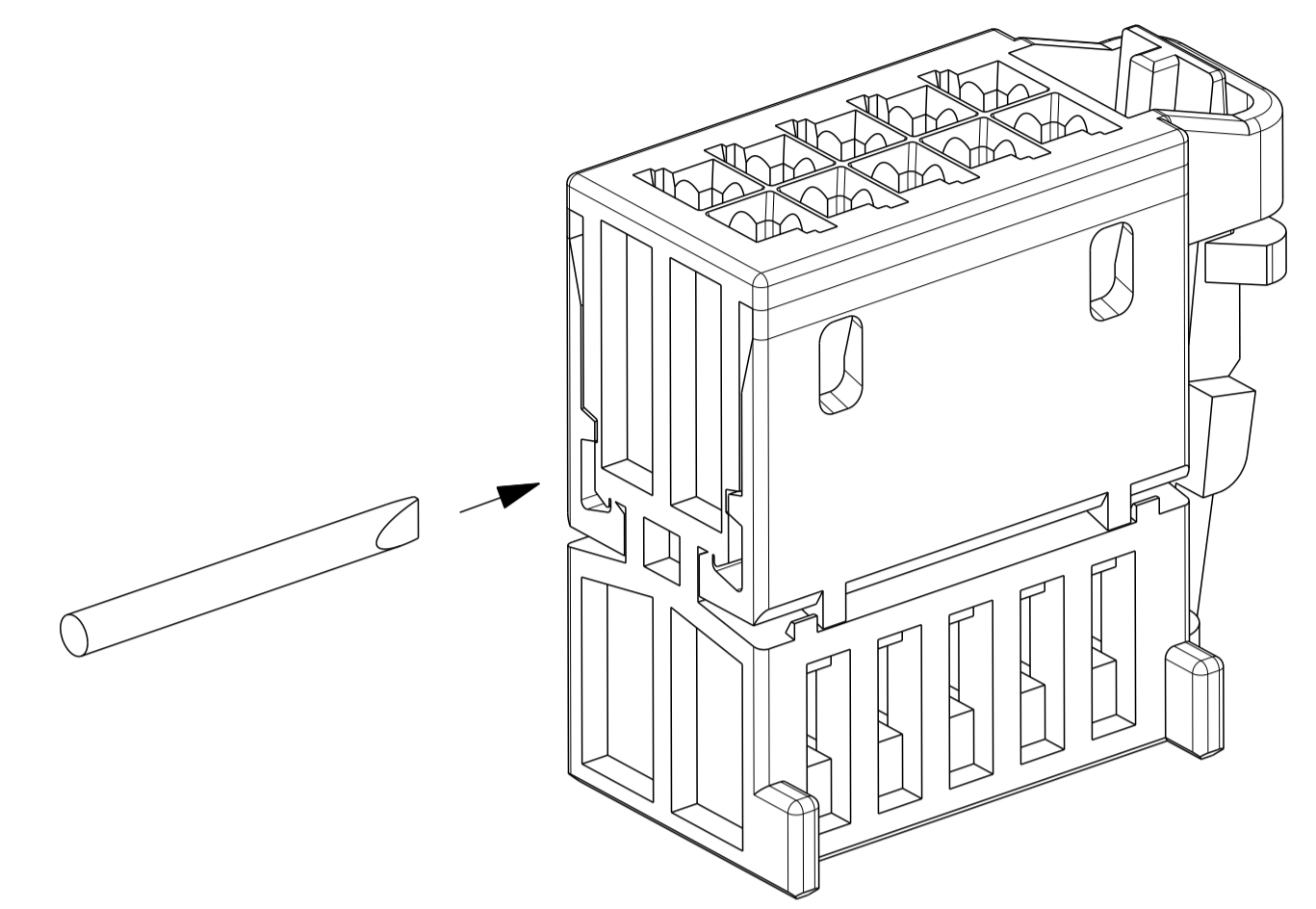

OPENING GUIDE: TO OPEN THE LOCKED RETAINER, USE A \varnothing 1x0.18MM SCREWDRIVER AND PUSH IT IN THE SHOWN OPENING.
Oeffnungsanleitung: Zum Oeffnen des verrasteten Deckels wird ein \varnothing 1x0.18mm Schraubendreher in die gezeigte Oeffnung gedrecks.

Bemerkungen

- 1 Passende Kontakte 1355717, 928999, 963715
- 2 Passende Stiftwanne siehe Zeichnung-Nr. 969587
- 3 Materialentnahme optional in Ausfuehrung und Lage nach Wahl des Herstellers moeglich
- 4 Verpackung: Schuettgut in Karton

NOTES

- 1 SUITABLE CONTACTS 1355717, 928999, 963715
- 2 SUITABLE PIN HEADER SEE DRAWING NO. 969587
- 3 MATERIAL REMOVAL OPTIONAL IN EXECUTION AND POSITION ACC. TO MANUFACTURER POSSIBLE
- 4 PACKAGING: LOOSE PIECE IN CARDBOX

PART NO	REV.	COD.	MATERIAL	COLOUR	WEIGHT [g]	POS.
1-1670990-4	A	A	PBT-GF10	DARK BROWN/dunkelbraun	2.04	1
1-1670990-2	A	B	PBT-GF10	GREY/grau	2.04	2
1-1670990-1	A	A	PBT-GF10	BLACK/schwarz	2.04	1

TOLERANCES UNLESS OTHERWISE SPECIFIED ACC. TO DIN 16901-140 CENTRIC TO NOMINAL DIMENSION. EDITION 1982-11 SHALL APPLY. Freimessstoleranzen nach DIN 16901-140. Es gilt die Ausgabe 1982-11.

THIS DRAWING IS A CONTROLLED DOCUMENT. DWN Madesh R 17AUG2012
 CHG Rudresh B T 31AUG2012

DIMENSIONS: MASSENHEITEN: mm. TOLERANCES UNLESS OTHERWISE SPECIFIED: ALLE WERTE TOLERANZEN.

0	PLC	±
1	PLC	±
2	PLC	±
3	PLC	±
4	PLC	±

MATERIAL: SEE TABLE. FINISH: SEE TABLE.

Customer Drawing

NAME: 10POS. MQS REC. HOUSING
10pol. MQS Buchsengehaeuse

SIZE: A1. CAGE CODE: 00779. DRAWING NO: 1670990. RESTRICTED TO: NUR FÜR: -

SCALE: 5:1. SHEET: 1 OF 1. REV: A2.