

REVISION RECORD				
REV	ECN	DESCRIPTION	DRFT	DATE
A		NEW		22.5.30

NOTES1:
 UL Standard
 1. Rated voltage/current : 300V / 12A
 2. Withstanding voltage : AC1600V/1Min.
 3. Wire range : 28~14AWG

IEC Standard

1. Pollution degree	2	2	3
Overvoltage category	II	III	III
Rate impulse voltage(KV)	2.5KV	2.5KV	2.5KV
Rate voltage(V)	320V	200V	200V
Rate current(A)	17.5A		

2. Wire range : 0.2~1.5mm²

NOTES2:
 1. Dimension shall be interpreted per ASME Y14.5-2009
 2. Pitch : 3.5mm, Poles : N=02~24P
 3. Stripping length : 8~9mm
 4. Operating temperature: -40°C~+130°C
 5. Undimensioned tolerances:

Pitch range in mm		Nominal dimension range in mm						-	∩	∇
TO	Over	TO	Over	TO	Over	TO	Over	0.1/10		
6	6 TO 10	10 TO 24	30 TO 60	60 TO 100	100 TO 150	150		<		
±0.15	±0.20	±0.30	±0.30	±0.50	±0.70	±1.00	±1.30	±2'		

6. RoHS Compliance

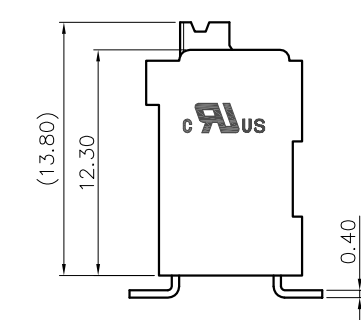
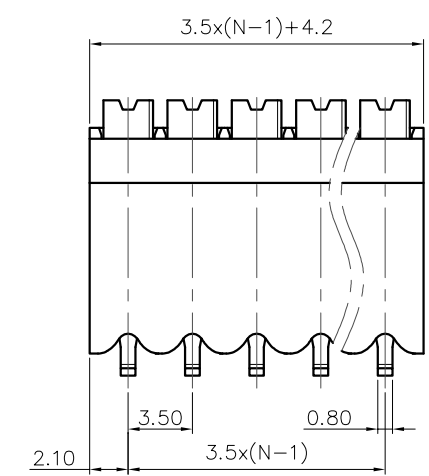
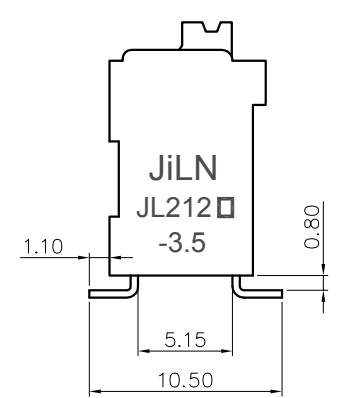
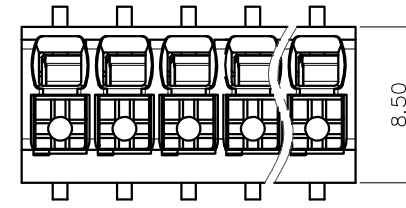

Ordering Information

JL212V-SMT- 350 XX B P 1

- Pitch 350=3.50PH
- No. of pins 2P~24P
- Housing Color: B=Black, G=Green, U=Blue, R=Red, W=White, Y=Yellow, □=Orange, E=Grey
- Packing: 0=Pe bag, T=Tube, A=Tray, P=Tube+Cap, R=Reel+Cap, M=Reel+Mylar

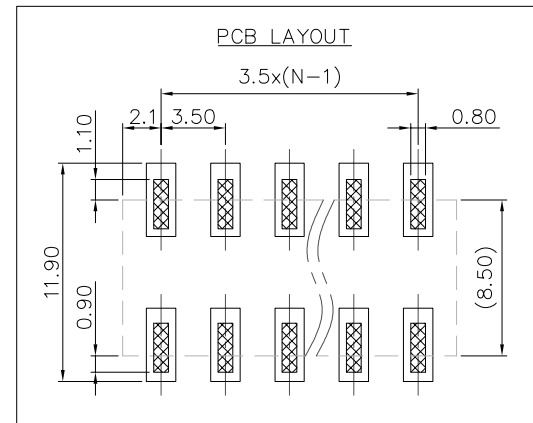

DRAW	SHUANGPING ZHENG	SCALE	FIT	JiLN ® 东莞市锦凌电子有限公司 DONGGUAN JINLING ELECTRONIC CO.,LTD	
CHECK	LICHAD LIU	UNIT	mm		
APPROVE	YONGLIANG GAO	SIZE	A4	PART NO.	JL212V-SMT-350XXBP1
		SHEET	1/1	TITLE:	JL212V-SMT-THR-3.5-XXP 弹簧式/立贴/黑色/管装
		PROJ.			