

THIS DRAWING IS UNPUBLISHED. RELEASED FOR PUBLICATION 20
 © COPYRIGHT 20 BY - ALL RIGHTS RESERVED.

LOC		DIST		REVISIONS			
P	LTR	DESCRIPTION	DATE	DWN	APVD		
A		REVISED PER ECR-15-007373	31JUL2015	RS	DD		
A1		REVISED PER ECR-19-000093	08JAN2019	SR	DD		

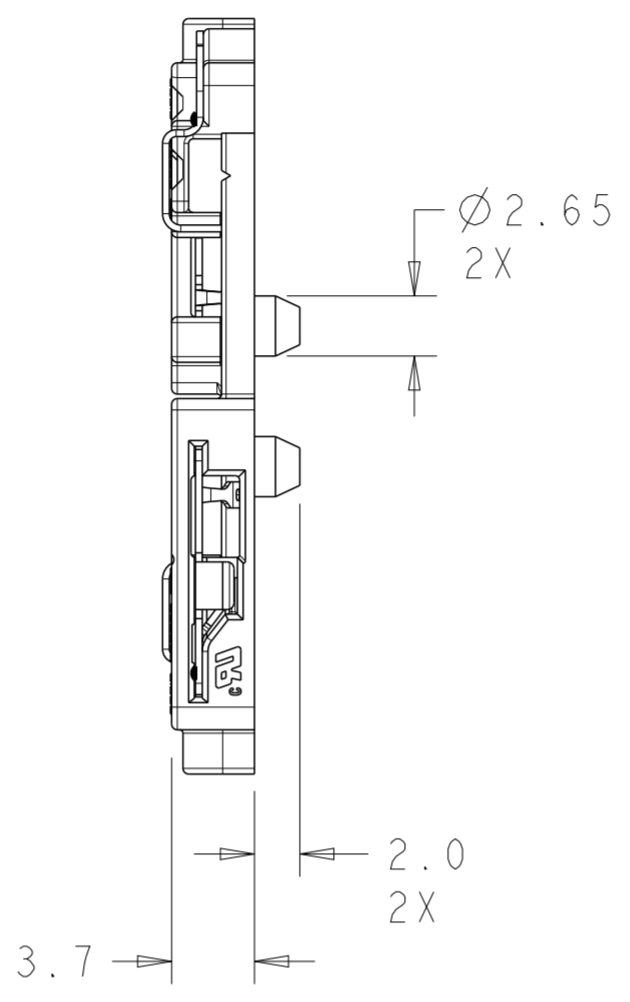
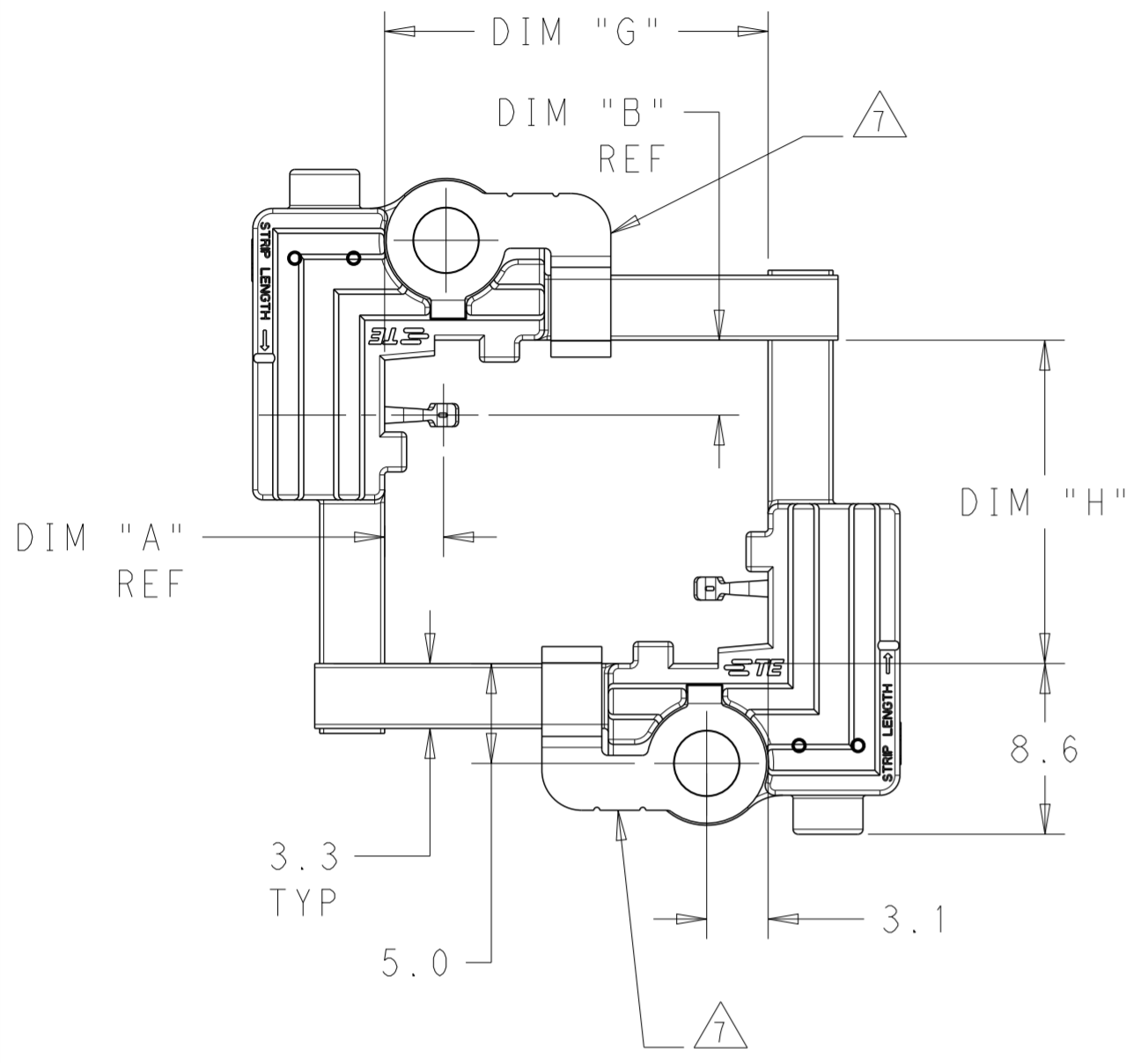

- 1. MATERIALS AND FINISH:
 - HOUSING: PBT-GF, COLOR: NATURAL
 - CONTACTS: COPPER ALLOY
 - FINISH: SEE TABLE
 - THERMAL SPRING: STAINLESS STEEL

2. MUST COMPLY WITH DIRECTIVE 2002/95/EC (ROHS)

3. REFER TO LED MANUFACTURER'S DATASHEET FOR LED DIMENSIONS

4. REFER TO LED DATASHEET FOR RECOMMENDED THERMAL INTERFACE MATERIALS

5. RECOMMENDED SCREW SIZE: M3 OR #4.
TORQUE SCREWS TO 2.5 in-lbf TO 4.0 in-lbf

6. WIRE TYPES AND SIZES ACCEPTED
 18, 20 AND 22 AWG SOLID WIRE
 18 AND 20 AWG PREBOND STRANDED WIRE
 18 AWG STRANDED WIRE (16 STRAND COUNT)
 MAX INSULATION OD: 2.10 MM
 STRIP LENGTH: 8.0±1.0

7. IN APPLICATIONS WHERE THE LED SUBSTRATE IS LESS THAN 1.50MM THICK A THERMAL SPRING IS REQUIRED. AS NOTED IN THE TABLE THE THERMAL SPRINGS WILL BE INSTALLED PRIOR TO SHIPMENT FROM THE TE FACTORY.

YES	38.30	38.30	2.26	2.00	GOLD OVER NICKEL	6-2154874-4
YES	28.30	28.30	2.26	2.00	GOLD OVER NICKEL	6-2154874-3
YES	19.30	19.30	1.85	1.55	GOLD OVER NICKEL	6-2154874-2
YES	13.80	13.80	1.85	1.55	GOLD OVER NICKEL	6-2154874-1
YES	24.15	24.15	2.26	2.00	GOLD OVER NICKEL	5-2154874-3
YES	16.15	16.15	2.26	2.00	GOLD OVER NICKEL	5-2154874-2
NO	22.30	22.30	3.75	2.95	TIN OVER NICKEL	5-2154874-1
NO	25.45	22.45	2.26	2.00	TIN OVER NICKEL	3-2154874-2
7. THERMAL SPRING	DIM H	DIM G	DIM B	DIM A	CONTACT PLATING	PART NUMBER

8. FOR COB-TO-HOLDER CROSS REFERENCE, REFER TO APPLICATION SPECIFICATION 114-32208.

THIS DRAWING IS A CONTROLLED DOCUMENT.

DWN: M. MOSTOLLER 22MAR2012
 CHK: M. MOSTOLLER 22MAR2012
 APVD: M. MOSTOLLER 22MAR2012

STE TE Connectivity

NAME: ONE PIECE ASSEMBLY LUMAWISE LED HOLDER, SCALABLE

PRODUCT SPEC: 108-133005
 APPLICATION SPEC: 114-32043

SIZE: A2 CAGE CODE: 00779 DRAWING NO: C-2154874 RESTRICTED TO: -

WEIGHT: -

Customer Drawing SCALE: 3:1 SHEET 1 OF 2 REV: A1

THIS DRAWING IS UNPUBLISHED. RELEASED FOR PUBLICATION 20
 © COPYRIGHT 20 BY - ALL RIGHTS RESERVED.

LOC		DIST		REVISIONS			
P	LTR	DESCRIPTION	DATE	DWN	APVD		
-	-	SEE SHEET 1	-	-	-		

DRILL AND TAP FOR M3
OR #4 MOUNTING
HARDWARE 2 PLACES

DRILL $\varnothing 2.75 \pm 0.05$
FOR ALIGNMENT POST
2 PLACES

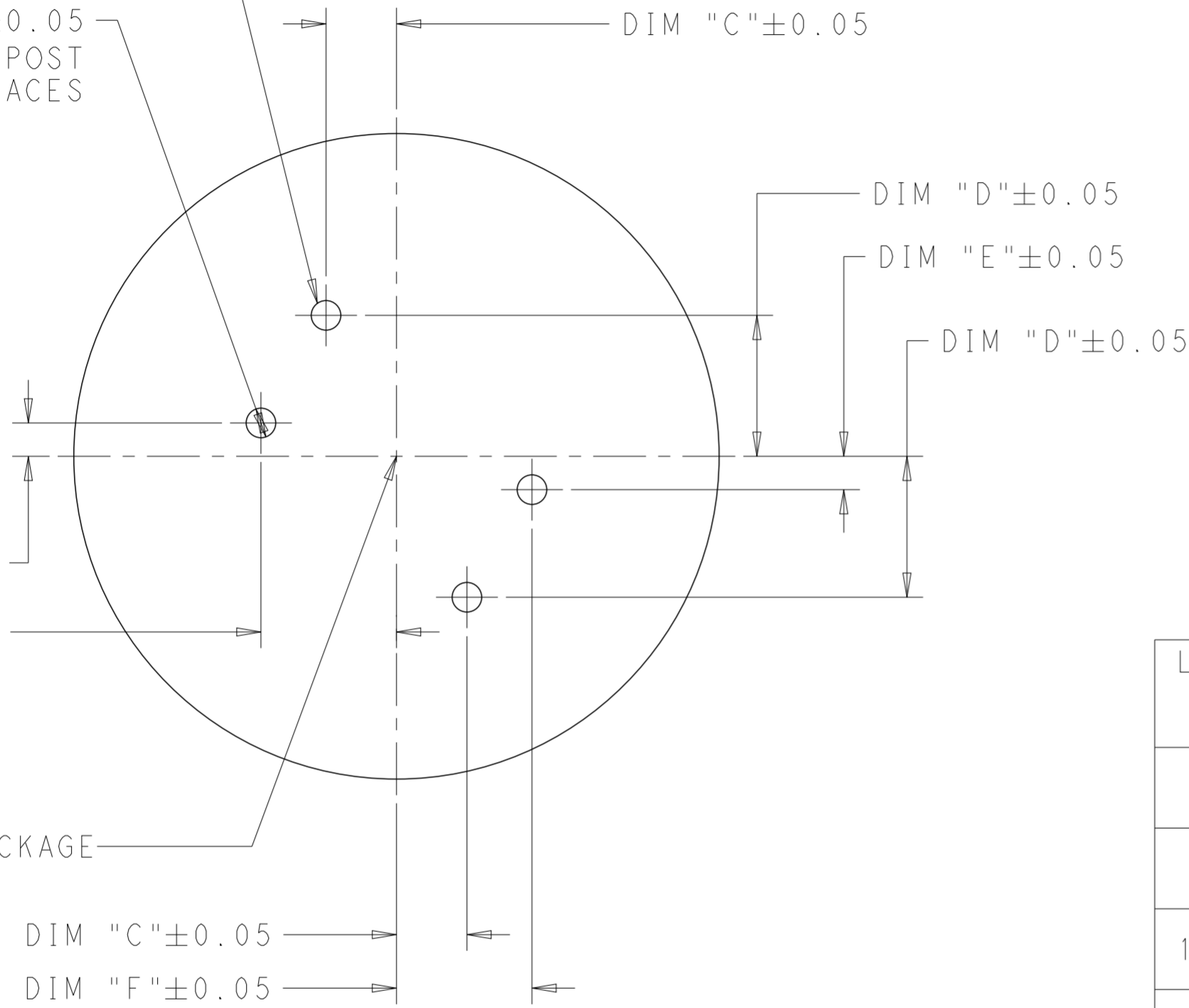

CENTER OF LED PACKAGE

DIM "C" ± 0.05

DIM "F" ± 0.05

RECOMMENDED MOUNTING HOLE PATTERN

LED DIMENSION $\triangle 3$	DIM "C"	DIM "D"	DIM "E"	DIM "F"	RECOMMENED SOCKET PART NUMBER
25.5 X 22.3	9.70	16.30	6.30	15.80	3-2154874-2
22.0 X 22.0	8.05	16.15	6.15	14.15	5-2154874-1
15.85 X 15.85	4.98	13.08	3.08	11.08	5-2154874-2
23.85 X 23.85	8.98	17.08	7.08	15.08	5-2154874-3
13.5 X 13.5	3.80	11.90	1.90	9.90	6-2154874-1
19.0 X 19.0	6.55	14.65	4.65	12.65	6-2154874-2
28.0 X 28.0	11.05	19.15	9.15	17.15	6-2154874-3
38.0 X 38.0	16.05	24.15	14.15	22.15	6-2154874-4

THIS DRAWING IS A CONTROLLED DOCUMENT.

DWN: M. MOSTOLLER 22MAR2012
 CHK: M. MOSTOLLER 22MAR2012
 APVD: M. MOSTOLLER 22MAR2012

STE TE Connectivity

NAME: ONE PIECE ASSEMBLY
LUMAWISE LED HOLDER, SCALABLE

PRODUCT SPEC: 108-133005
 APPLICATION SPEC: 114-32043

SIZE: A2 CAGE CODE: 00779 DRAWING NO: C-2154874 RESTRICTED TO: -
 WEIGHT: - SCALE: 3:1 SHEET 2 OF 2 REV: A1

MATERIAL: - Customer Drawing

DIMENSIONS: mm
 TOLERANCES UNLESS OTHERWISE SPECIFIED:
 0 PLC \pm
 1 PLC ± 0.2
 2 PLC ± 0.13
 3 PLC \pm
 4 PLC \pm
 ANGLES \pm
 FINISH