

Description

CD4518B Dual BCD Up Counter and CD4520B Dual Binary Up Counter each consist of two identical, internally synchronous 4-stage counters. The counter stages are D-type flip-flops having interchangeable CL^{CK} and ENABLE lines for incrementing on either the positive-going or negative-going transition. For single unit operation the ENABLE input is maintained high and the counter advances on each positive-going transition of the CL^{CK}. The counters are cleared by high levels on their RESET lines.

The counter can be cascaded in the ripple mode by connecting Q4 to the enable input of the subsequent counter while the CL^{CK} input of the latter is held low.

Features

- High Voltage Types (20V Rating)
- CD4518B Dual BCD Up Counter
- CD4520B Dual Binary Up Counter
- Medium Speed Operation
- 6MHz Typical Cl^{CK} Frequency at 10V
- Positive or Negative Edge Triggering
- Synchronous Internal Carry Propagation
- 100% Tested for Quiescent Current at 20V
- Standardized Symmetrical Output Characteristics Meets All Requirements of JEDEC Tentative Standard No. 13B, "Standard Specifications for Description of 'B' Series CMOS Devices"
- 5V, 10V and 15V Parametric Ratings
- Maximum Input Current of 1 μ A at 18V Over Full Pack
- Wide Temperature Range; 100nA at 18V and +25 $^{\circ}$ C
- Noise Margin (Over Full Package/Temperature Range)
 - 1V at VDD = 5V
 - 2V at VDD = 10V
 - 2.5V at VDD = 15V

Applications

- Multistage Synchronous Counting
- Multistage Ripple Counting
- Frequency Dividers

ORDERING INFORMATION

DEVICE	Package Type	MARKING	Packing	Packing Qty
CD4518BEG	DIP16	CD4518BE	TUBE	1000pcs/box
CD4520BEG	DIP16	CD4520BE	TUBE	1000pcs/box
CD4518BDRG	SOP16	CD4518B	REEL	2500pcs/reel
CD4520BDRG	SOP16	CD4520B	REEL	2500pcs/reel

Pin Connection

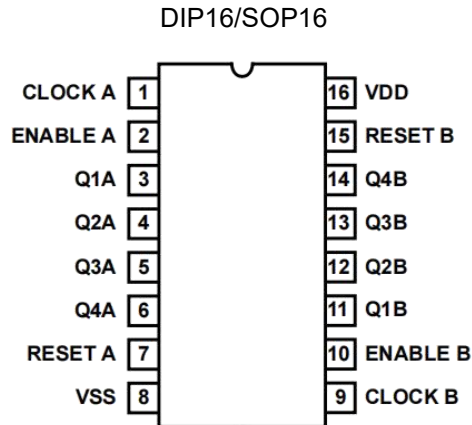

Functional Diagram

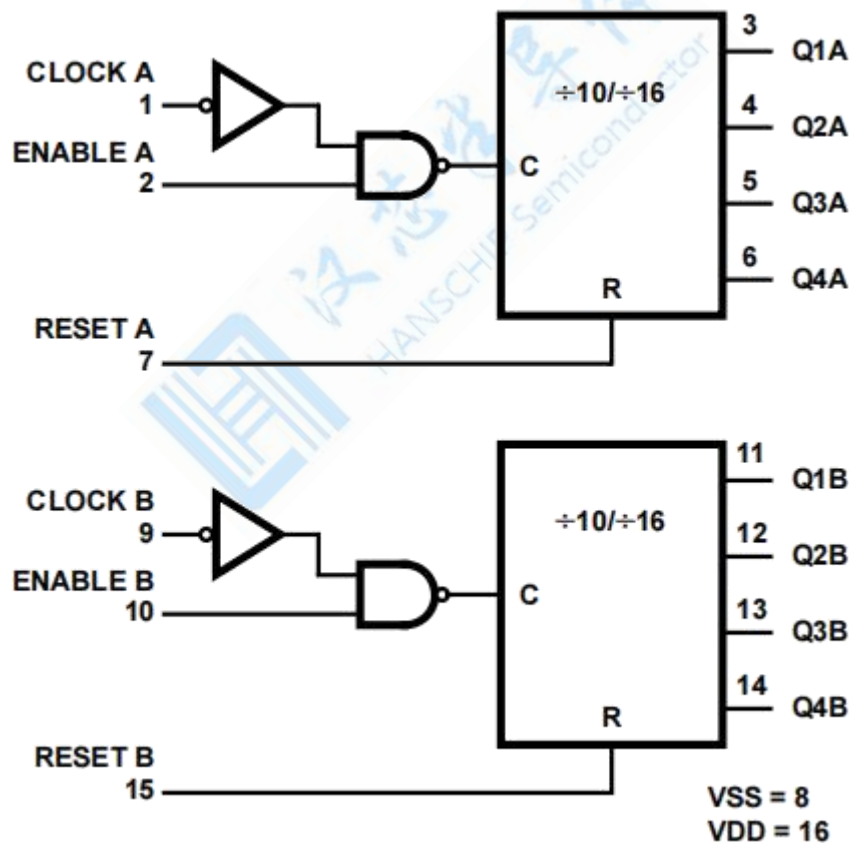

Absolutute Maximum Ratings

Parameter	Min	Max	Unit
DC Supply Voltage Range, (VDD) (Voltage Referenced to VSS Terminals)	-	+20	V
Input Voltage Range, All Inputs	-	+0.5	V
DC Input Current, Any One Input	-	10	mA
Operating Temperature Range Package Types D, F, K, H	-55	+125	°C
Storage Temperature Range (TSTG)	-65	+150	°C
Lead Temperature (During Soldering) At Distance 1/16 ± 1/32 Inch (1.59mm ± 0.79mm) from case for 10s Maximum	-	+265	°C
	-		-

Reliability Information

Parameter	Min	Max	Unit
Thermal Resistance	-	-	θ_{ja}/θ_{jc}
Ceramic DIP and FRIT Package	80	20	°C/W
Flatpack Package	70	20	°C/W
Maximum Package Power Dissipation (PD)	-	+125	°C
For $T_A = -55^{\circ}\text{C}$ to $+100^{\circ}\text{C}$ (Package Type E, N, M)	-	500	mW
For $T_A = +100^{\circ}\text{C}$ to $+125^{\circ}\text{C}$ (Package Type E, N, M)	12	200	mW
Device Dissipation per Output Transistor	-	100	mW
For $T_A =$ Full Package Temperature Range (All Package Types)	-	-	-
Junction Temperature	-	+175	°C

DC ELECTRICAL PERFORMANCE CHARACTERISTICS

PARAMETER	SYMBOL	CONDITIONS (NOTE 1)		GROUP A SUBGROUPS	TEMPERATURE	LIMITS		UNITS
						MIN	MAX	
Supply Current	IDD	VDD = 20V, VIN = VDD or GND		1	+25°C	-	10	A
				2	+125°C	-	1000	A
		VDD = 18V, VIN = VDD or GND		3	-55°C	-	10	A
Input Leakage Current	IIL	VIN = VDD or GND	VDD = 20	1	+25°C	-100	-	nA
			VDD = 18V	2	+125°C	-1000	-	nA
				3	-55°C	-100	-	nA
Input Leakage Current	IIH	VIN = VDD or GND	VDD = 20	1	+25°C	-	100	nA
			VDD = 18V	2	+125°C	-	1000	nA
				3	-55°C	-	100	nA
Output Voltage	VOL15	VDD = 15V, No Load		1, 2, 3	+25°C, +125°C, -55°C	-	50	mV
Output Voltage	VOH15	VDD = 15V, No Load (Note 3)		1, 2, 3	+25°C, +125°C, -55°C	14.95	-	V
Output Current (Sink)	IOL5	VDD = 5V, VOUT = 0.4V		1	+25°C	0.53	-	mA
Output Current (Sink)	IOL10	VDD = 10V, VOUT = 0.5V		1	+25°C	1.4	-	mA
Output Current (Sink)	IOL15	VDD = 15V, VOUT = 1.5V		1	+25°C	3.5	-	mA
Output Current (Source)	IOH5A	VDD = 5V, VOUT = 4.6V		1	+25°C	-	-0.53	mA
Output Current (Source)	IOH5B	VDD = 5V, VOUT = 2.5V		1	+25°C	-	-1.8	mA
Output Current (Source)	IOH10	VDD = 10V, VOUT = 9.5V		1	+25°C	-	-1.4	mA
Output Current (Source)	IOH15	VDD = 15V, VOUT = 13.5V		1	+25°C	-	-3.5	mA
N Threshold Voltage	VNTH	VDD = 10V, ISS = -10 A		1	+25°C	-2.8	-0.7	V
P Threshold Voltage	VPTH	VSS = 0V, IDD = 10 A		1	+25°C	0.7	2.8	V
Functional	F	VDD = 2.8V, VIN = VDD or GND		7	+25°C	VOH > VDD/2	VOL < VDD/2	V
		VDD = 20V, VIN = VDD or GND		7	+25°C			
		VDD = 18V, VIN = VDD or GND		8A	+125°C			
		VDD = 3V, VIN = VDD or GND		8B	-55°C			
Input Voltage Low(Note 2)	VIL	VDD = 5V, VOH > 4.5V, VOL < 0.5V		1, 2, 3	+25°C, +125°C, -55°C	-	1.5	V
Input Voltage High(Note 2)	VIH	VDD = 5V, VOH > 4.5V, VOL < 0.5V		1, 2, 3	+25°C, +125°C, -55°C	3.5	-	V
Input Voltage Low(Note 2)	VIL	VDD = 15V, VOH > 13.5V, VOL < 1.5V		1, 2, 3	+25°C, +125°C, -55°C	-	4	V
Input Voltage High(Note 2)	VIH	VDD = 15V, VOH > 13.5V, VOL < 1.5V		1, 2, 3	+25°C, +125°C, -55°C	11	-	V

NOTES:

1. All voltages referenced to device GND, 100% testing being implemented.
2. Go/No Go test with limits applied to inputs.
3. For accuracy, voltage is measured differentially to VDD. Limit is 0.050V max.

AC ELECTRICAL PERFORMANCE CHARACTERISTICS

PARAMETER	SYMBOL	CONDITIONS (NOTE 1, 2)	GROUP A SUBGROUPS	TEMPERATURE	LIMITS		UNITS
					MIN	MAX	
Propagation DelayClock to Output	TPHL1 TPLH1	VDD = 5V, VIN = VDD or GND	9	+25°C	-	560	ns
			10, 11	+125°C, -55°C	-	756	ns
Propagation DelayReset to Output	TPHL2	VDD = 5V, VIN = VDD or GND	9	+25°C	-	650	ns
			10, 11	+125°C, -55°C	-	878	ns
Transition Time(Note 2)	TTHL TTLH	VDD = 5V, VIN = VDD or GND	9	+25°C	-	200	ns
			10, 11	+125°C, -55°C	-	270	ns
Maximum Clock Input Frequency	FCL	VDD = 5V, VIN = VDD or GND	9	+25°C	1.5	-	MHz
			10, 11	+125°C, -55°C	1.11	-	MHz

NOTES:

- CL = 50pF, RL = 200K, Input TR, TF < 20ns.
- 55°C and +125°C limits guaranteed, 100% testing being implemented.

ELECTRICAL PERFORMANCE CHARACTERISTICS

PARAMETER	SYMBOL	CONDITIONS	NOTES	TEMPERATURE	LIMITS		UNITS
					MIN	MAX	
Supply Current	IDD	VDD = 5V, VIN = VDD or GND	1, 2	-55°C, +25°C	-	5	μA
				+125°C	-	150	μA
		VDD = 10V, VIN = VDD or GND	1, 2	-55°C, +25°C	-	10	μA
				+125°C	-	300	μA
		VDD = 15V, VIN = VDD or GND	1, 2	-55°C, +25°C	-	10	μA
				+125°C	-	600	μA
Output Voltage	VOL	VDD = 5V, No Load	1, 2	+25°C, +125°C, -55°C	-	50	mV
Output Voltage	VOL	VDD = 10V, No Load	1, 2	+25°C, +125°C, -55°C	-	50	mV
Output Voltage	VOH	VDD = 5V, No Load	1, 2	+25°C, +125°C, -55°C	4.95	-	V
Output Voltage	VOH	VDD = 10V, No Load	1, 2	+25°C, +125°C, -55°C	9.95	-	V
Output Current (Sink)	IOL5	VDD = 5V, VOUT = 0.4V	1, 2	+125°C	0.36	-	mA
				-55°C	0.64	-	mA
Output Current (Sink)	IOL10	VDD = 10V, VOUT = 0.5V	1, 2	+125°C	0.9	-	mA
				-55°C	1.6	-	mA
Output Current (Sink)	IOL15	VDD = 15V, VOUT = 1.5V	1, 2	+125°C	2.4	-	mA
				-55°C	4.2	-	mA
Output Current (Source)	IOH5A	VDD = 5V, VOUT = 4.6V	1, 2	+125°C	-	-0.36	mA
				-55°C	-	-0.64	mA
Output Current (Source)	IOH5B	VDD = 5V, VOUT = 2.5V	1, 2	+125°C	-	-1.15	mA
				-55°C	-	-2.0	mA
Output Current (Source)	IOH10	VDD = 10V, VOUT = 9.5V	1, 2	+125°C	-	-0.9	mA
				-55°C	-	-1.6	mA
Output Current (Source)	IOH15	VDD = 15V, VOUT = 13.5V	1, 2	+125°C	-	-2.4	mA
				-55°C	-	-4.2	mA
Input Voltage Low	VIL	VDD = 10V, VOH > 9V, VOL < 1V	1, 2	+25°C, +125°C, -55°C	-	3	V
Input Voltage High	VIH	VDD = 10V, VOH > 9V, VOL < 1V	1, 2	+25°C, +125°C, -55°C	+7	-	V

ELECTRICAL PERFORMANCE CHARACTERISTICS (Continued)

PARAMETER	SYMBOL	CONDITIONS	NOTES	TEMPERATURE	LIMITS		UNITS
					MIN	MAX	
Propagation Delay Cl ^o ck to Output	TPHL1	VDD = 10V	1, 2, 3	+25°C	-	230	ns
	TPLH1	VDD = 15V	1, 2, 3	+25°C	-	160	ns
Propagation Delay Reset to Output	TPHL2	VDD = 10V	1, 2, 3	+25°C	-	225	ns
		VDD = 15V	1, 2, 3	+25°C	-	170	ns
Transition Time	TTHLTTLH	VDD = 10V	1, 2, 3	+25°C	-	100	ns
		VDD = 15V	1, 2, 3	+25°C	-	80	ns
Maximum Cl ^o ck Input Frequency	FCL	VDD = 10V	1, 2, 3	+25°C	3	-	MHz
		VDD = 15V	1, 2, 3	+25°C	4	-	MHz
Maximum Cl ^o ck Rise and Fall Time	TRCLTFCL	VDD = 5V	1, 2, 3, 4	+25°C	-	15	s
		VDD = 10V	1, 2, 3, 4	+25°C	-	5	s
		VDD = 15V	1, 2, 3, 4	+25°C	-	5	s
Minimum Enable Pulse Width	TW	VDD = 5V	1, 2, 3	+25°C	-	400	ns
		VDD = 10V	1, 2, 3	+25°C	-	200	ns
		VDD = 15V	1, 2, 3	+25°C	-	140	ns
Minimum Reset Pulse Width	TW	VDD = 5V	1, 2, 3	+25°C	-	250	ns
		VDD = 10V	1, 2, 3	+25°C	-	110	ns
		VDD = 15V	1, 2, 3	+25°C	-	80	ns
Minimum Cl ^o ck Pulse Width	TW	VDD = 5V	1, 2, 3	+25°C	-	200	ns
		VDD = 10V	1, 2, 3	+25°C	-	100	ns
		VDD = 15V	1, 2, 3	+25°C	-	70	ns
Input Capacitance	CIN	Any Input	1, 2	+25°C	-	7.5	pF

NOTES:

- All voltages referenced to device GND.
- The parameters listed on Table 3 are controlled via design or process and are not directly tested. These parameters are characterized on initial design release and upon design changes which would affect these characteristics.
- CL = 50pF, RL = 200K, Input TR, TF < 20ns.
- If more than one unit is cascaded, TRCL should be made less than or equal to the sum of the transition time and the fixed propagation delay of the output of the driving stage for the estimated capacitive load.

POST IRRADIATION ELECTRICAL PERFORMANCE CHARACTERISTICS

PARAMETER	SYMBOL	CONDITIONS	NOTES	TEMPERATURE	LIMITS		UNITS
					MIN	MAX	
Supply Current	IDD	VDD = 20V, VIN = VDD or GND	1, 4	+25°C	-	25	μA
N Threshold Voltage	VNTH	VDD = 10V, ISS = -10μA	1, 4	+25°C	-2.8	-0.2	V
N Threshold Voltage Delta	ΔVTN	VDD = 10V, ISS = -10μA	1, 4	+25°C	-	1	V
P Threshold Voltage	VTP	VSS = 0V, IDD = 10μA	1, 4	+25°C	0.2	2.8	V
P Threshold Voltage Delta	ΔVTP	VSS = 0V, IDD = 10μA	1, 4	+25°C	-	1	V
Functional	F	VDD = 18V, VIN = VDD or GND	1	+25°C	VOH > VDD/2	VOL < VDD/2	V
		VDD = 3V, VIN = VDD or GND					
Propagation Delay Time	TPHL TPLH	VDD = 5V	1, 2, 3, 4	+25°C	-	1.35 x +25°C Limit	ns

NOTES:

- All voltages referenced to device GND.
- CL = 50pF, RL = 200K, Input TR, TF < 20ns.
- See Table 2 for +25°C limit.
- Read and Record

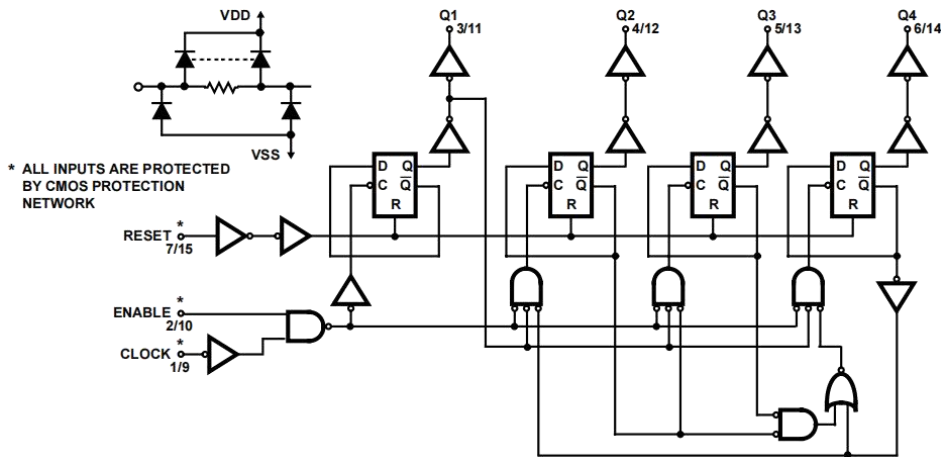
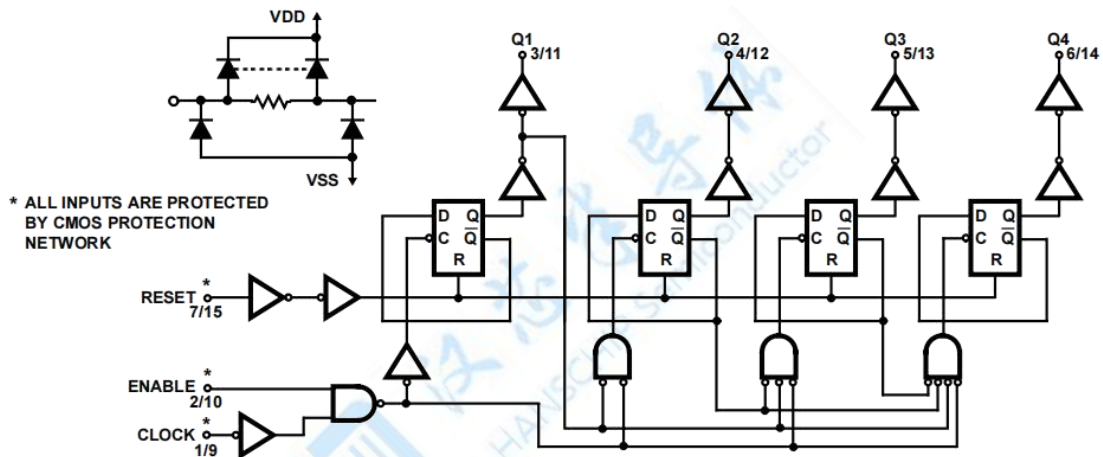
Logic Diagrams

FIGURE 1. DECADE COUNTER (CD4518B) LOGIC DIAGRAM FOR ONE OF TWO IDENTICAL COUNTERS

FIGURE 2. BINARY COUNTER (CD4520B) LOGIC DIAGRAM FOR ONE OF TWO IDENTICAL COUNTERS
TRUTH TABLE

CLOCK	ENABLE	RESET	ACTION
↑	1	0	Increment Counter
0	↓	0	Increment Counter
↓	X	0	No Change
X	↑	0	No Change
↑	0	0	No Change
1	↓	0	No Change
X	X	1	Q1 thru Q4 = 0

X = Don't Care 1 = High State 0 = Low State

Typical Performance Curves

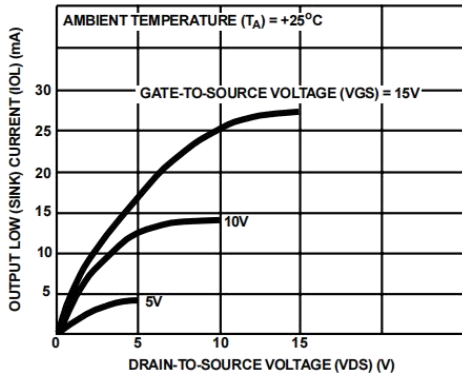

FIGURE 3. TYPICAL OUTPUT LOW (SINK) CURRENT CHARACTERISTICS

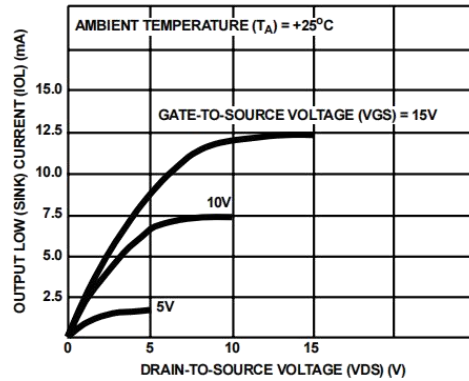

FIGURE 4. MINIMUM OUTPUT LOW (SINK) CURRENT CHARACTERISTICS

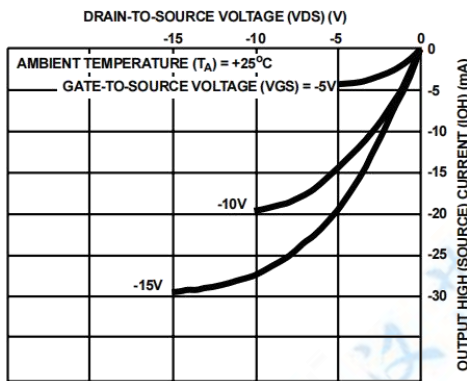

FIGURE 5. TYPICAL OUTPUT HIGH (SOURCE) CURRENT CHARACTERISTICS

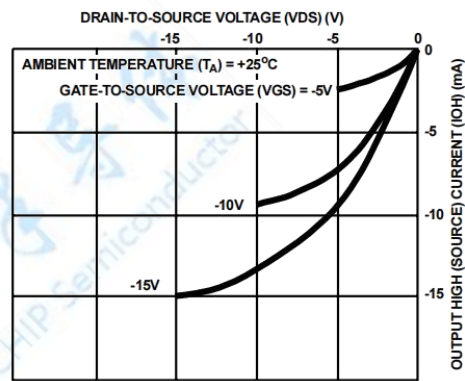

FIGURE 6. MINIMUM OUTPUT HIGH (SOURCE) CURRENT CHARACTERISTICS

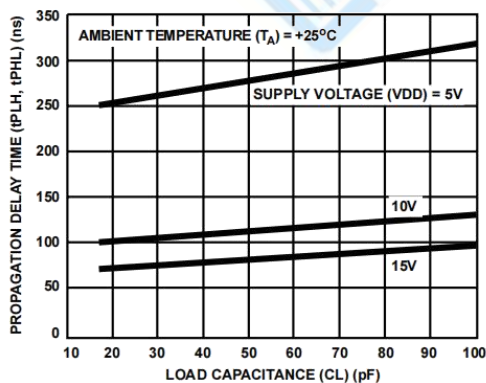

FIGURE 7. TYPICAL PROPAGATION DELAY vs LOAD CAPACITANCE, CL, CLOCK OR ENABLE TO OUTPUT

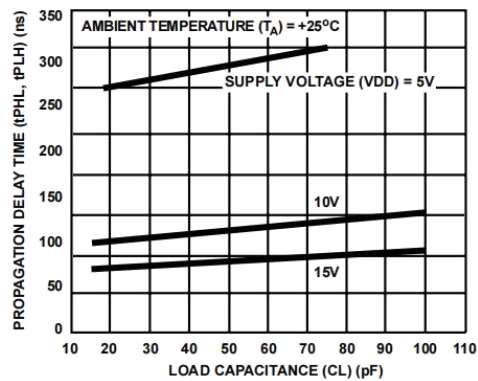

FIGURE 8. TYPICAL PROPAGATION DELAY TIME vs LOAD CAPACITANCE, RESET TO OUTPUT

Typical Performance Curves

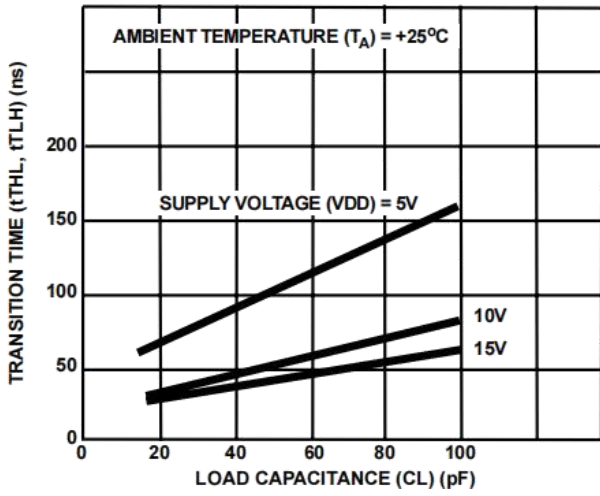

FIGURE 9. TYPICAL TRANSITION TIME vs LOAD CAPACITANCE

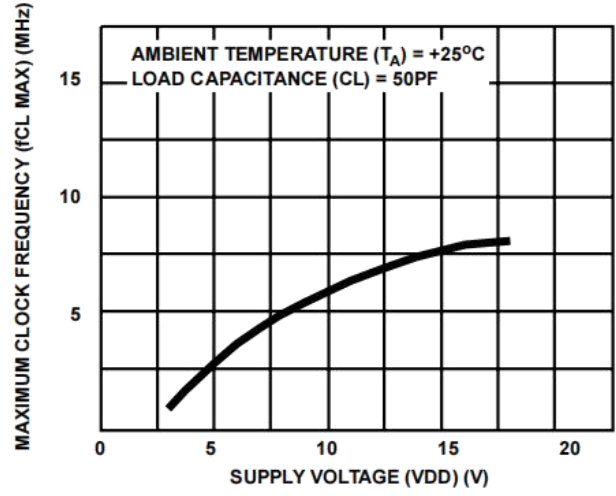

FIGURE 10. TYPICAL MAXIMUM CLOCK FREQUENCY vs SUPPLY VOLTAGE

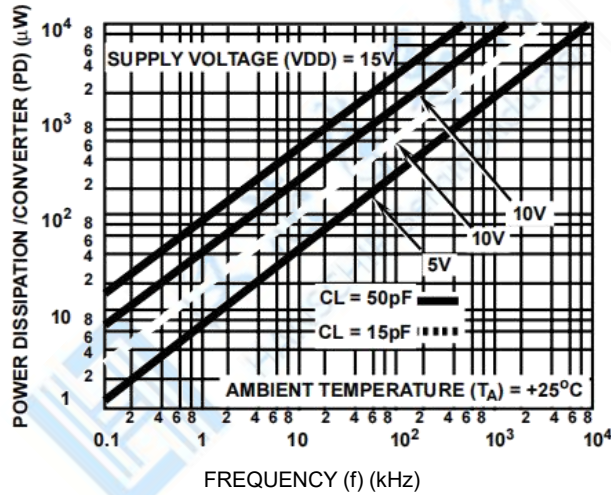

FIGURE 11. TYPICAL POWER DISSIPATION CHARACTERISTICS

Timing Diagrams

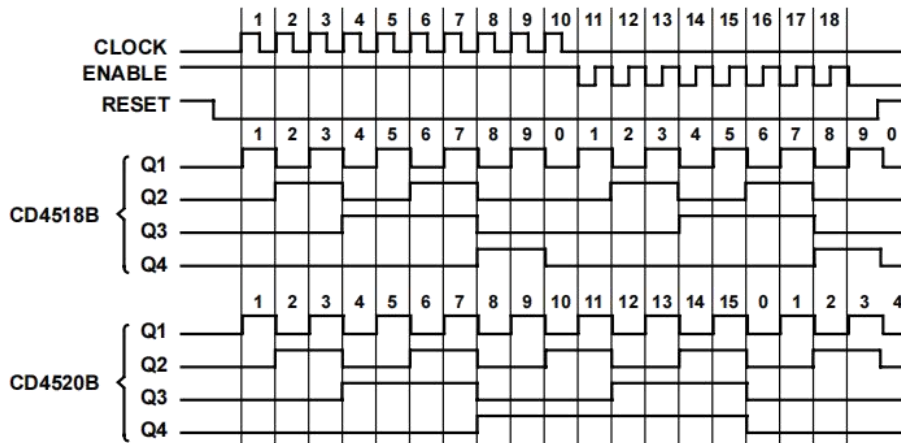

FIGURE 12. TIMING DIAGRAMS FOR CD4518B AND CD4520B

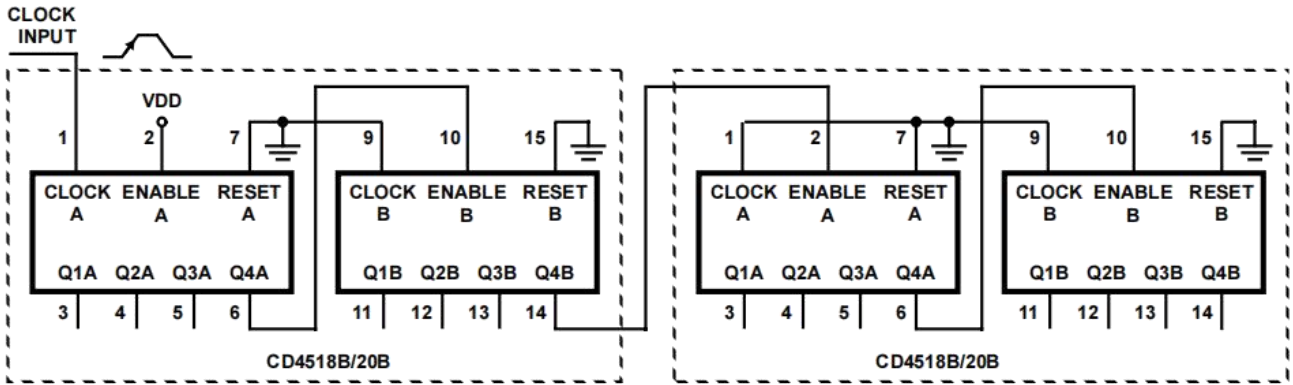
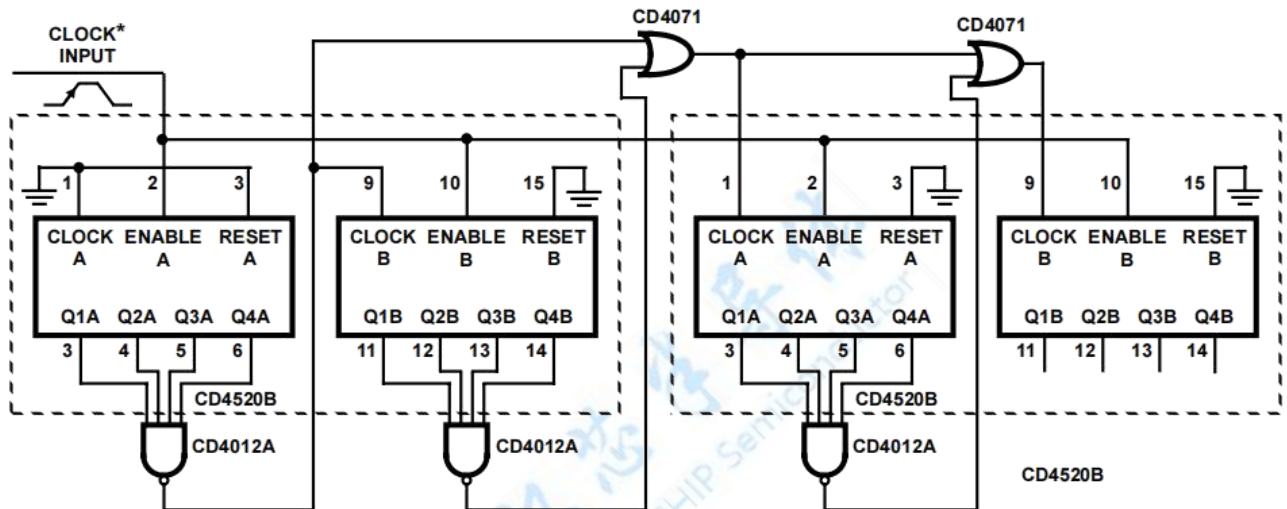

FIGURE 13. RIPPLE CASCADING OF FOUR COUNTERS WITH POSITIVE EDGE TRIGGERING



For synchronous cascading, the clock transition time should be made less than or equal to the sum of the fixed propagation delay at 15pF and the transition time of the output driver stage for the estimated capacitive load.

FIGURE 14. SYNCHRONOUS CASCADING OF FOUR BINARY COUNTERS WITH NEGATIVE EDGE TRIGGERING

Physical Dimensions

SOP16

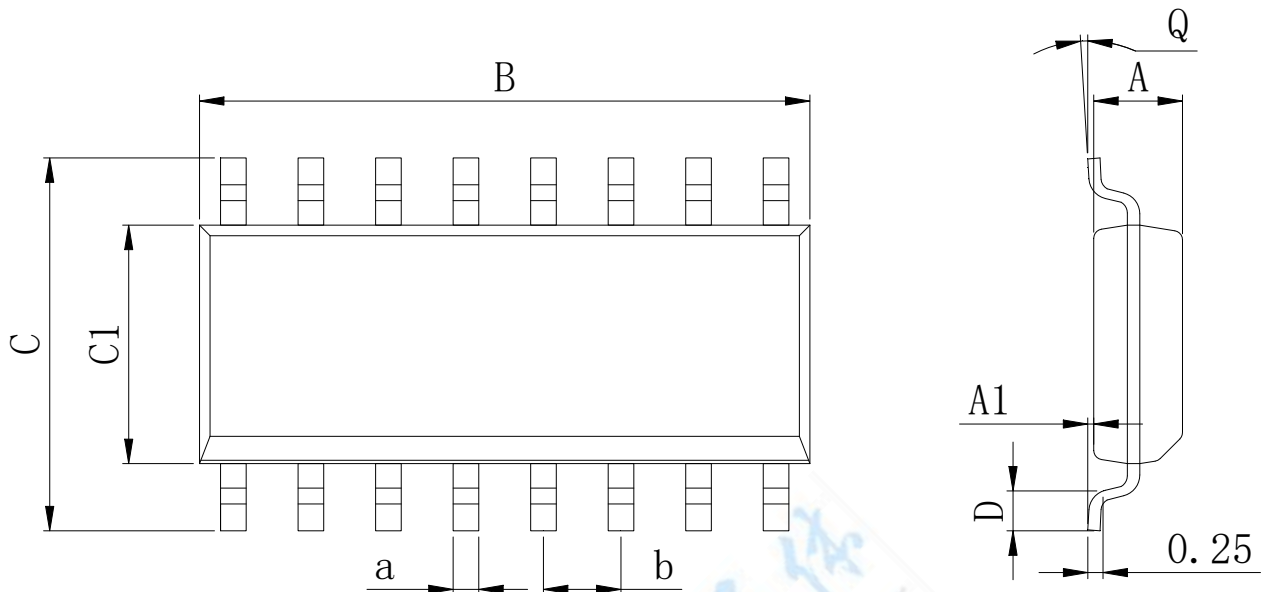
Dimensions In Millimeters(SOP16)

Symbol:	A	A1	B	C	C1	D	Q	a	b
Min:	1.35	0.05	9.80	5.80	3.80	0.40	0°	0.35	1.27 BSC
Max:	1.55	0.20	10.0	6.20	4.00	0.80	8°	0.45	

DIP16

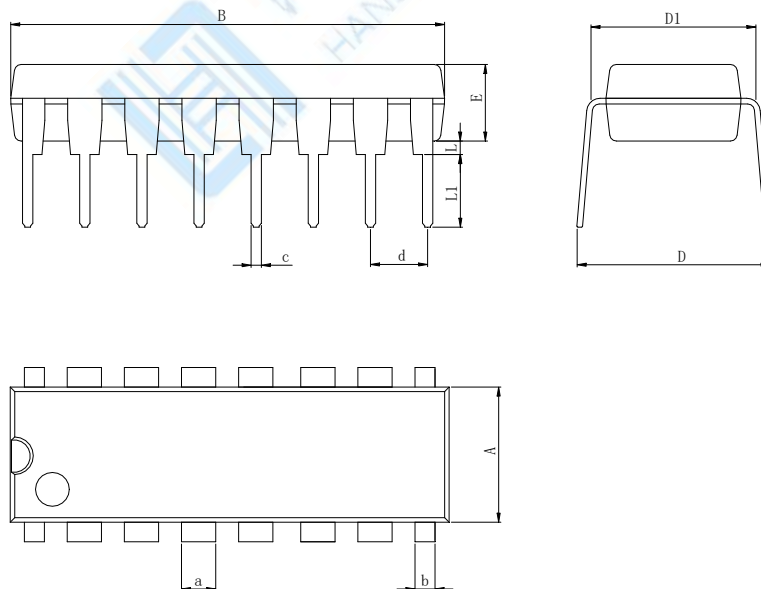
Dimensions In Millimeters(DIP16)

Symbol:	A	B	D	D1	E	L	L1	a	b	c	d
Min:	6.10	18.94	8.40	7.42	3.10	0.50	300	1.50	0.85	0.40	2.54 BSC
Max:	6.68	19.56	9.00	7.82	3.55	0.70	3.60	1.55	0.90	0.50	

IMPORTANT STATEMENT:

Shenzhen Hanschip semiconductor co.,ltd. reserves the right to change the products and services provided without notice. Customers should obtain the latest relevant information before ordering, and verify the timeliness and accuracy of this information.

Customers are responsible for complying with safety standards and taking safety measures when using our products for system design and machine manufacturing to avoid potential risks that may result in personal injury or property damage.

Our products are not licensed for applications in life support, military, aerospace, etc., so we do not bear the consequences of the application of these products in these fields.

Our documentation is only permitted to be copied without any tampering with the content, so we do not accept any responsibility or liability for the altered documents.

