

Specifications:
规格:
Voltage rating:600V AC/DC
额定电压: 600V AC/DC
Current rating:9A AC/DC
额定电流: 9A AC/DC
Withstanding voltage:1500V AC/minute
耐受电压: 1500V AC/分钟
Temperature range:-25°C~+85°C
温度范围: -25°C~+85°C
Insulation resistance: $\geq 100\text{M}\Omega$
绝缘电阻: $\geq 100\text{M}\Omega$
Contact resistance: $\leq 10\text{m}\Omega$
接触电阻: $\leq 10\text{m}\Omega$
After environmental testing: $\leq 20\text{m}\Omega$
环境测试后: ≤ 20 兆欧

X9357 W V- 2xXX - N2 SN
① ② ③ ④ ⑤ ⑥

- 1.Series No.
- 2.Category:W-Wafer
- 3.Welding Board Angle: V- Stright 180°
- 4.Row No.Pin No:2xXX-2x01P~2x12P
- 5.Material: N0-PA66 94V-0:N2-PA66 94V-2
- 6.Plating Category: SN-Bright Tin Plating
V01-Plating Gold Flash

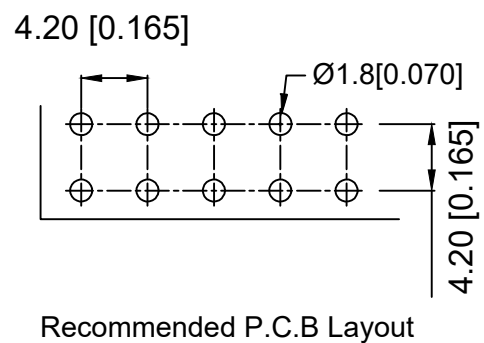
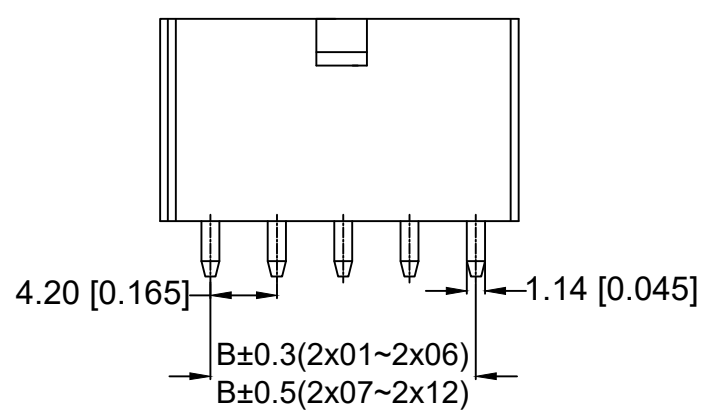

Poles	Dimensions(mm)		Poles	Dimensions(mm)	
	A	B		A	B
2*01	5.40	-	2*07	30.60	25.20
2*02	9.60	4.20	2*08	34.80	29.40
2*03	13.80	8.40	2*09	39.00	33.60
2*04	18.00	12.60	2*10	43.20	37.80
2*05	22.20	16.80	2*11	47.40	42.00
2*06	26.40	21.00	2*12	51.60	46.20

X9357WV-2xXX-N2SN	PA66 UL94V-2	Brass	X9357HM
PART NO	Material	Material(Pin)	Suitable XKB Housing

REVISIONS							UNSPECIFIED TOLERANCES			XKB			
MARK	DESCRIPTION	DATE	REVISED	APPROVED			DSND	DATE	SCALE: N/A	MODEL TYPE:	WEIGHT	SHEET	REVISION
							DWN	DATE	VIEW:	4.2 mm Crimp Style Connectors	1.0g	1/1	A0
							CHKD	DATE	UNIT: mm/in	PART NO.:			
							APPD	DATE	SIZE: A4	X9357WV-2xXX-N2SN			
										X-X9357WV-2xXX-N2SN			
KXB INDUSTRIAL PRECISION CO.,LIMITED													