

### GENERAL DESCRIPTION

BL8071G series are a group of positive voltage output, high precise, and low power consumption voltage regulator. Voltages are selectable in 100mV steps within a range of 1.2V to 5.0V. It also can be customized on command.

BL8071G series have excellent load and line transient response and good temperature characteristics, which can assure the stability of chip and power system. And it uses trimming technique to guarantee output voltage accuracy within  $\pm 2\%$ .

BL8071G series are available in SOT-223, TO-252 packages, which are lead (Pb)- free.

### FEATURES

- Low quiescent current: 100uA (Typ.)
- Low dropout voltage:  
50mV@ $I_{OUT}=0.1A$ ,  $V_{OUT}=3.3V$  (Typ.)  
600mV@ $I_{OUT}=1.5A$ ,  $V_{OUT}=3.3V$ (Typ.)
- High PSRR: 65dB@1KHz (Typ.)
- Low temperature coefficient:  $\pm 100\text{ppm}/^\circ\text{C}$
- Output voltage range: 1.2V~5.0V
- Highly accurate:  $\pm 2\%$
- Thermal shutdown
- Overcurrent protection

### APPLICATIONS

- Reference voltage source
- Battery powered equipment
- PC peripherals
- Wireless devices
- Instrumentation

### TYPICAL APPLICATION

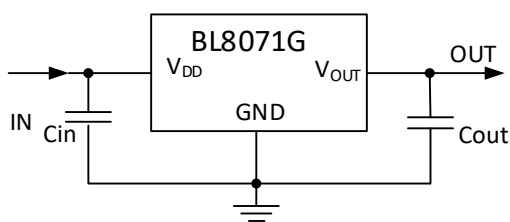

**Note:** Input capacitor ( $C_{IN}=4.7\mu\text{F}$ ) and output capacitor ( $C_{OUT}=4.7\mu\text{F}$ ) are recommended in all application circuit.

### BLOCK DIAGRAM

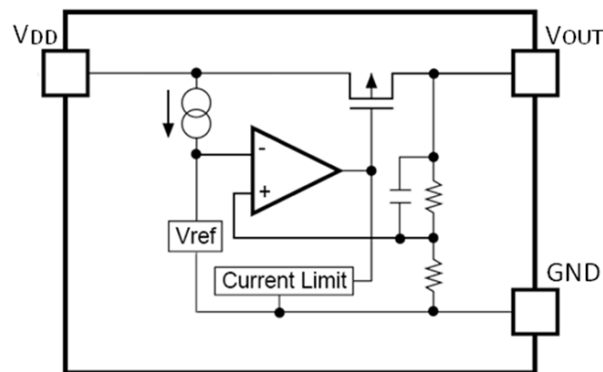

## ORDERING INFORMATION

BL8071G [1](#) [2](#) [3](#) [4](#) [5](#)

Code	Description
<a href="#">1</a>	Temperature&RoHS: C:-40~85°C ,Pb Free RoHS Std.
<a href="#">2</a>	Package type: LA: SOT-223 (A) LB: SOT-223 (B) O:TO-252
<a href="#">3</a>	Packing type: TR:Tape&Reel (Standard)
<a href="#">4</a>	Output voltage: e.g. 12=1.2V 18=1.8V 25=2.5V 33=3.3V 50=5.0V
<a href="#">5</a>	Voltage accuracy: 1=±1%(Customized) Blank(default)=±2%

## MARKING DESCRIPTON

Output Voltage Code X

VOUT	Code	VOUT	Code	VOUT	Code
1.2V	2	2.7V	7	3.9V	9
1.3V	3	2.8V	8	4.0V	0
1.4V	4	2.9V	9	4.1V	1
1.5V	5	3.0V	0	4.2V	2
1.8V	8	3.1V	1	4.3V	3
2.0V	0	3.2V	2	4.4V	4
2.1V	1	3.3V	3	4.5V	5
2.2V	2	3.4V	4	4.6V	6
2.3V	3	3.5V	5	4.7V	7
2.4V	4	3.6V	6	4.8V	8
2.5V	5	3.7V	7	4.9V	9
2.6V	6	3.8V	8	5.0V	0

## PIN CONFIGURATION

<b>Product classification</b>		<b>BL8071GCLATR□□</b>
<b>JBXX</b> LLLLYW	<b>JB</b> :Product code	
	<b>XX</b> :Output voltage	
	<b>A</b> : A type	
	<b>LLLL</b> :LOT NO.	
<b>YW</b> :Date code		
<b>Product classification</b>		<b>BL8071GCLBTR□□</b>
<b>JBXX</b> LLLLYW	<b>JB</b> :Product code	
	<b>XX</b> :Output voltage	
	<b>B</b> : B type	
	<b>LLLL</b> :LOT NO.	
<b>YW</b> :Date code		
<b>Product classification</b>		<b>BL8071GCOTR□□</b>
<b>JBXX</b> LLLLYW	<b>JB</b> :Product code	
	<b>XX</b> :Output voltage	
	<b>B</b> : B type	
	<b>LLLL</b> :LOT NO.	
<b>YW</b> :Date code		
<b>VDD</b>	Supply voltage input	
<b>GND</b>	Ground pin	
<b>VOUT</b>	Output voltage	

**XX**: Output Voltage, e.g. 18=1.8V 33=3.3V

**Y**: The Year of manufacturing, "1" stands for year 20X1, "2" stands for year 20X2, and "8" stands for year 20X8. (X=0,1,2,...9)

**W**: The week of manufacturing. "A" stands for week 1, "Z" stands for week 26, "A" stands for week 27, "Z" stands for week 52.

The date code of the 53rd week is the same as that of the first week of the next year. For example, the date code of the 53rd week of 2017 is the same as that of the first week of 2018, which are 1801 and 8A.

## ABSOLUTE MAXIMUM RATING

Parameter		Value
Max input voltage		6V
Operating junction temperature (T <sub>j</sub> )		125°C
Max Output current		1.5A
Package thermal resistance (θ <sub>JC</sub> )	SOT-223	20°C/W
	TO-252	10°C / W
Storage temperature (T <sub>s</sub> )		-65°C~150°C
Lead temperature & time		260°C, 10 Sec
ESD (HBM)		>2000V

## RECOMMENDED WORK CONDITIONS

Parameter		Value
Input voltage range		Max. 6V
Ambient temperature		-40°C~85°C

## ELECTRICAL CHARACTERISTICS

Test Conditions: C<sub>IN</sub>=4.7uF, C<sub>OUT</sub>=4.7uF, T<sub>A</sub>=25°C, unless otherwise specified.

Symbol	Parameter		Conditions	Min	Typ	Max	Units
V <sub>DD</sub>	Input voltage			1.5*		6	V
V <sub>OUT</sub>	Output voltage	V <sub>OUT</sub> >1.5	V <sub>DD</sub> =Set V <sub>OUT</sub> +1V 1mA≤I <sub>OUT</sub> ≤10mA	V <sub>OUT</sub> X0.98	V <sub>OUT</sub>	V <sub>OUT</sub> X1.02	V
		V <sub>OUT</sub> ≤1.5		V <sub>OUT</sub> -0.03		V <sub>OUT</sub> +0.03	
I <sub>OUT</sub> (Max.) **	Maximum output current				1.5		A
V <sub>DROP</sub>	Dropout voltage		V <sub>OUT</sub> =3.3V, I <sub>OUT</sub> =1.5A		550	650	mV
$\frac{\Delta V_{out}}{\Delta V_{in} \cdot V_{out}}$	Line regulation		I <sub>OUT</sub> =10mA, 4V≤V <sub>DD</sub> ≤6V		0.05	0.2	%/V
ΔV <sub>out</sub>	Load regulation		V <sub>DD</sub> =Set V <sub>OUT</sub> +1V 1mA≤I <sub>OUT</sub> ≤2.5A		30	60	mV
I <sub>Q</sub>	Supply current		V <sub>DD</sub> =Set V <sub>OUT</sub> +1V, V <sub>OUT</sub> floating		100	150	uA
$\frac{\Delta V_{out}}{\Delta T \cdot V_{out}}$	Output voltage temperature coefficient		I <sub>OUT</sub> =10mA		±100		ppm/°C
PSRR	Ripple rejection		f=1KHz, ripple=0.5Vp-p, V <sub>DD</sub> =Set V <sub>OUT</sub> +1V		65		dB
T <sub>SD</sub>	Thermal shutdown temp		V <sub>IN</sub> =Set V <sub>OUT</sub> +1V, I <sub>OUT</sub> =10mA		170		°C
T <sub>SH</sub>	Thermal shutdown hysteresis		V <sub>IN</sub> =Set V <sub>OUT</sub> +1V, I <sub>OUT</sub> =10mA		35		°C

**Note:** \*I<sub>OUT</sub>=500mA@V<sub>OUT</sub>=1.2V

\*\*The maximum power rating of each package is a constant, so along with the change of I<sub>LOAD</sub>, the V<sub>DD</sub>-V<sub>OUT</sub> should be controlled to a certain range to ensure the normal operation.

## THERMAL CONSIDERATIONS

We have to take heat dissipation into great consideration when output current or differential voltage of input and output voltage is large. Because in such cases, the power dissipation consumed by BL8071G is very large. BL8071G series uses SOT-223 package type and its thermal resistance is about 20°C/W. And the copper area of application board can affect the total thermal resistance. If copper area is 5cm\*5cm (two sides), the resistance is about 30°C/W. So the total thermal resistance is about 20°C/W + 30°C/W. In this case, the power dissipation should be limited less than 1.2W. We can decrease total thermal resistance by increasing copper area in application board. When there is no good heat dissipation copper are in PCB, the total thermal resistance will be as high as 120°C/W, then the power dissipation of BL8071G could allow on itself is less than 1W. And furthermore, BL8071G will work at junction temperature higher than 125°C under such condition and no lifetime is guaranteed.

## CURRENT LIMIT MODE

Current Limit module can keep chip and power system away from danger when the load current is higher than the current limit threshold. When  $V_{OUT}$  decrease the Short Circuit Current will fold back to a small value.

## SHORT CIRCUIT PROTECTION

When  $V_{OUT}$  short to GND, the short circuit protection will be triggered and clamp the output current to approximately 300mA. This feature protects the regulator from over current and damage due to overheating.

## TYPICAL PERFORMANCE CHARACTERISTICS

Load Regulation  
(Vout=3.3V)

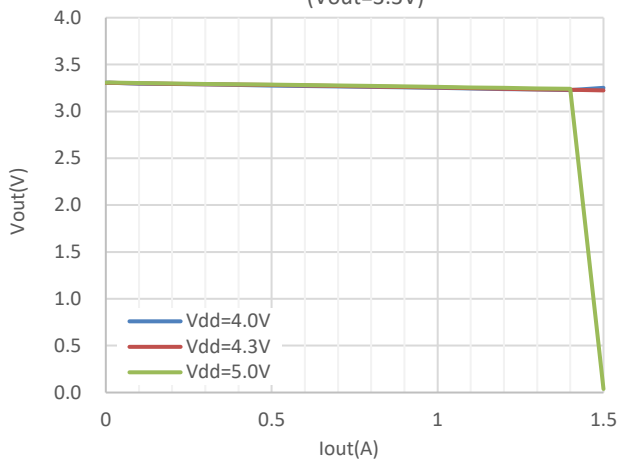

Line Regulation  
(Vout=3.3V)

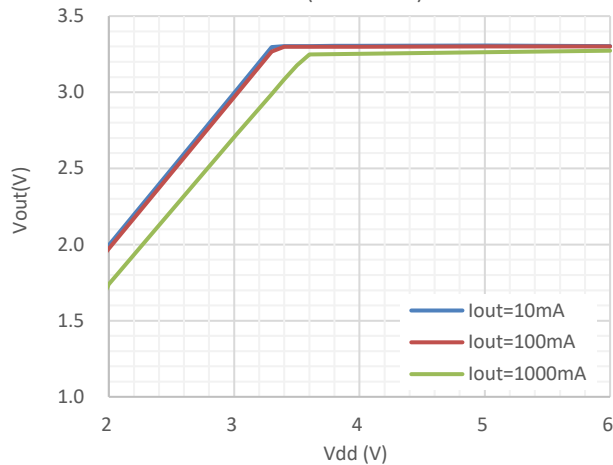

Dropout Voltage  
(Vout=3.3V)

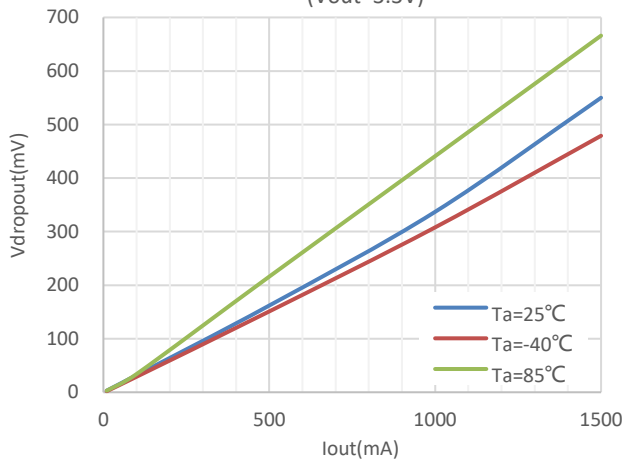

Iq

(Vout=3.3V)

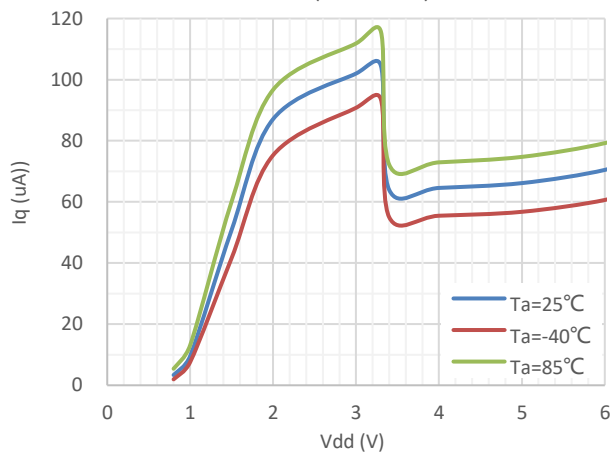

Vout vs. Temp  
(Vdd=5V, Iout=10mA)

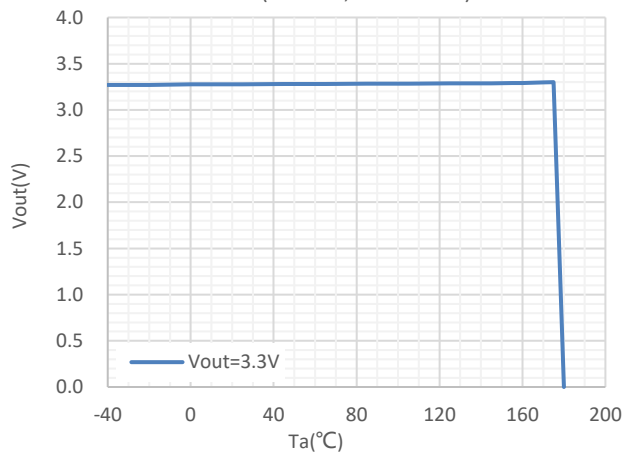

Load Transient Response

(Vdd=5V, Vout=3.3V, Iout=10mA-1A, Trise=10uS)

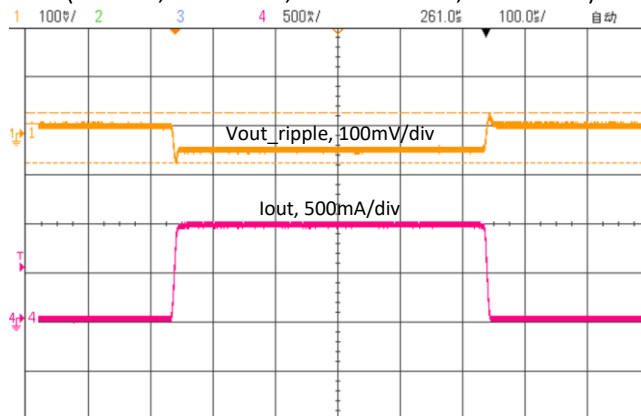

CH1: Vout\_ripple, CH4: Iout

## PACKAGE OUTLINE

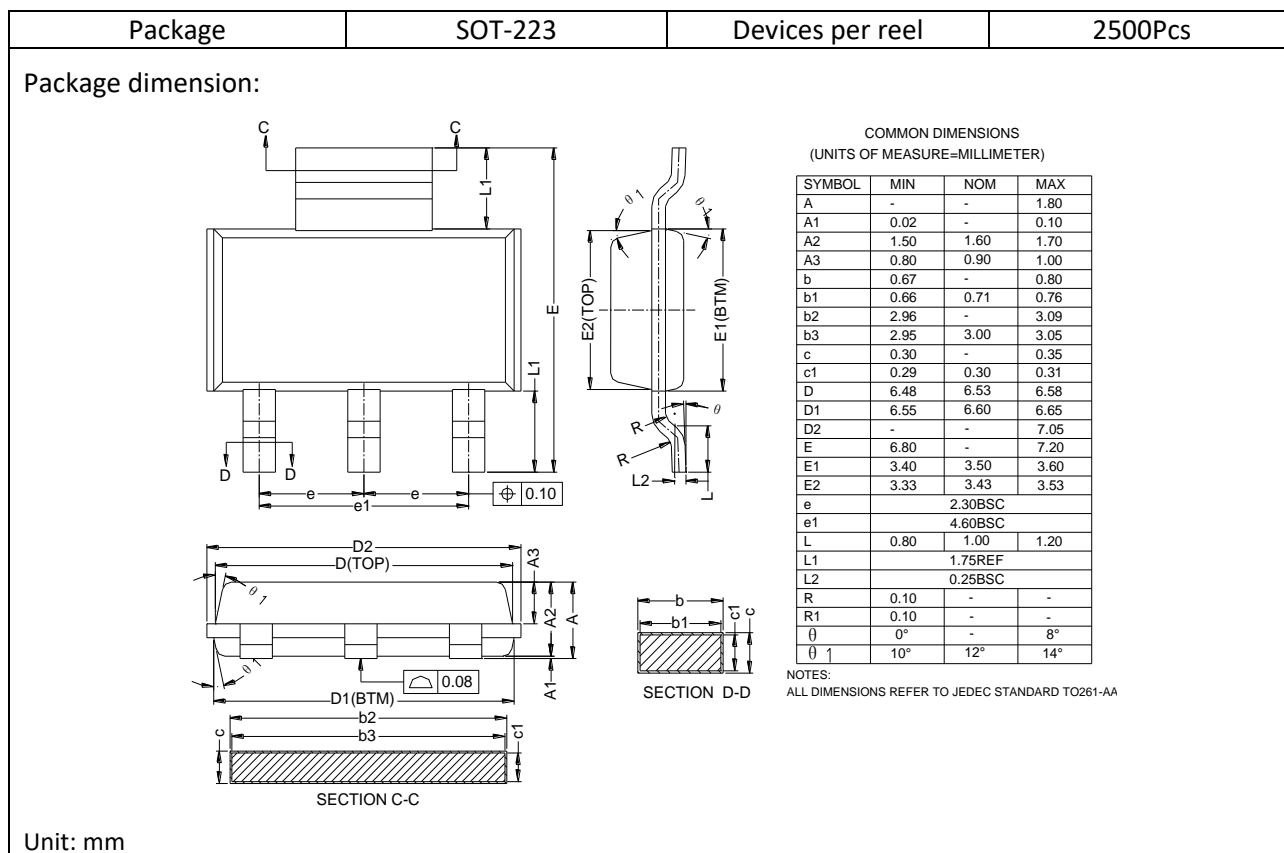

# BL8071G

