

MSKSEMI

SEMICONDUCTOR



ESD



TVS



TSS



MOV



GDT



PLED

Product data sheet

概述:

AMS1117 C D 是一款低压差的线性稳压器。

特点:

- 包括三端可调输出和固定电压输出版本（固定电压包括 1.2V, 1.8V, 2.5V, 3.3V, 5V等, 其他电压规格可根据用户定制）
- 最大输出电流为 1A
- 输出电压精度高达±2%
- 稳定工作电压范围为高达 12V
- 电压线性度为 0.2%
- 负载线性度为 0.4%
- 环境温度: T_A 的范围是 $-20^{\circ}\text{C} \sim 125^{\circ}\text{C}$

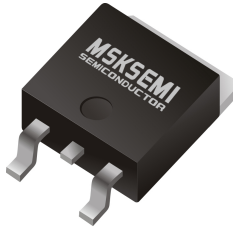

TO-252

用途:

- 计算机主板、显卡
- LCD 监视器及 LCD TV
- DVD 解码板
- ADSL 等设备
- 开关电源的后级稳压

功能图:

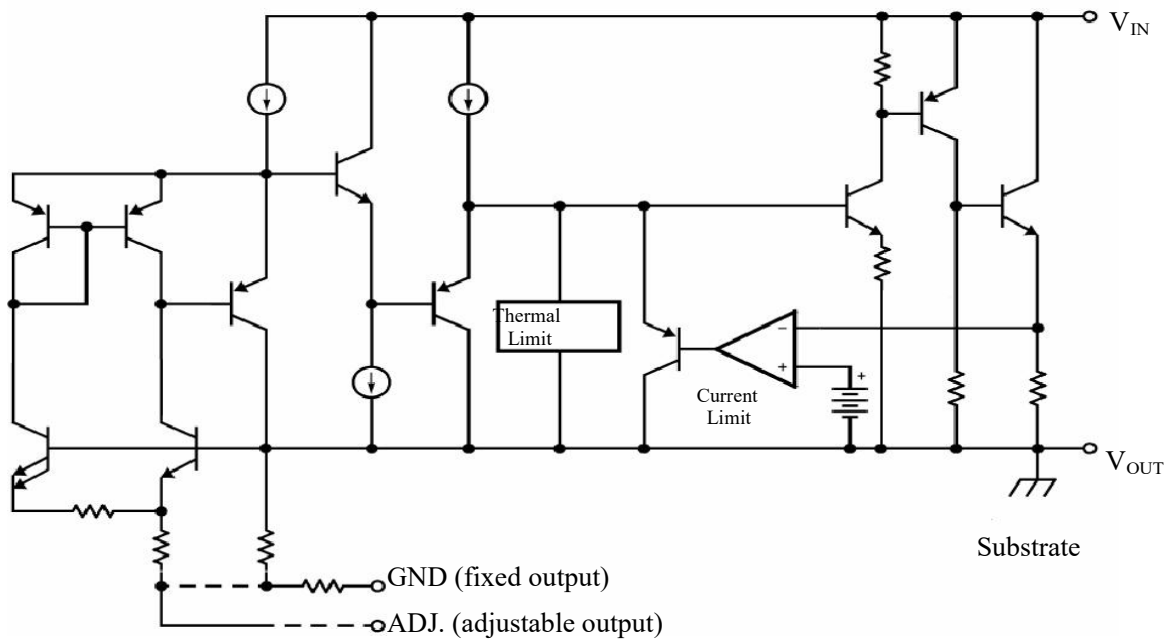

引脚排列图:

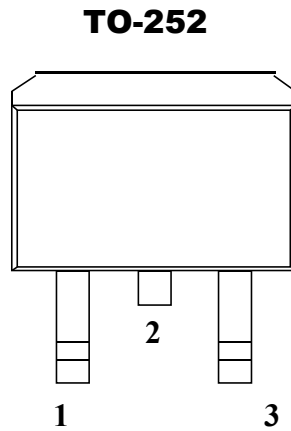

引脚定义:

引脚号	符号	定义
1	GND	接地脚
2	Vout	输出端
3	Vin	输入端

固定电
压型

引脚号	符号	定义
1	Adj.	可调端
2	Vout	输出端
3	Vin	输入端

可调电
压型

极限值:

参数名称	符号	数值	单位
最大输入电压	Vin	18	V
最大节温	TJ	125	°C
最大环境温度	TA	125	°C
贮存温度	Ts	-65~+150	°C
焊接温度和时间			

推荐工作条件:

名称	最小	推荐	最大	单位
输入电压范围			15	V
工作环境温度	0		125	°C

主要参数和工作特性:

T_j=25°C

参数	参数说明	条件	最小值	典型值	最大值	单位
V _{ref}	参考电压	I _{out} =10mA, V _{in} -V _{out} =2V 10mA ≤ I _{out} ≤ 1A, 1.5V ≤ V _{in} -V _{out} ≤ 10V	1.225	1.25	1.275	V
V _{out}	输出电压	AMS1117CD-1.2 10mA ≤ I _{out} ≤ 1A, 2.7V ≤ V _{in} ≤ 10V	1.176	1.2	1.224	V
		AMS1117CD-1.5 10mA ≤ I _{out} ≤ 1A, 3.0V ≤ V _{in} ≤ 10V	1.47	1.5	1.53	V
		AMS1117CD-1.8 10mA ≤ I _{out} ≤ 1A, 3.25 V ≤ V _{in} ≤ 10V	1.764	1.80	1.836	V
		AMS1117CD-2.5 10mA ≤ I _{out} ≤ 1A, 3.9 V ≤ V _{in} ≤ 10V	2.45	2.50	2.55	V
		AMS1117CD-3.3 10mA ≤ I _{out} ≤ 1A, 5.3 V ≤ V _{in} ≤ 12V	3.235	3.3	3.365	V
		AMS1117CD-5.0 10mA ≤ I _{out} ≤ 1A, 6.5V ≤ V _{in} ≤ 12V	4.9	5	5.1	V
ΔV _{out}	电压线性度	AMS1117CD-ADJ I _{out} =10mA, V ≤ V _{in} -V _{out} ≤ 10V		5	18	mV
		AMS1117CD-1.2 I _{out} =10mA, 2.7V ≤ V _{in} ≤ 10V		5	18	mV
		AMS1117CD-1.5 I _{out} =10mA, 2.75V ≤ V _{in} ≤ 10V		5	18	mV
		AMS1117CD-1.8 I _{out} =10mA, 3.25 V ≤ V _{in} ≤ 10V		5	18	mV
		AMS1117CD-2.5 I _{out} =10mA, 3.9 V ≤ V _{in} ≤ 10V		5	18	mV
		AMS1117CD-3.3 I _{out} =10mA, 5.3 V ≤ V _{in} ≤ 12V		9	18	mV
ΔV _{out}	负载线性度	AMS1117CD-ADJ V _{in} = 3.25V, 10mA ≤ I _{out} ≤ 1A		9	18	mV
		AMS1117CD-1.2 V _{in} = 2.7 V, 10mA ≤ I _{out} ≤ 1A		9	18	mV
		AMS1117CD-1.5V V _{in} = 3.25V, 10mA ≤ I _{out} ≤ 1A		9	18	mV

主要参数和工作特性:

		AMS1117CD-1.8 $V_{in} = 3.25V, 10mA \leq I_{out} \leq 1A$		10	18	mV
		AMS1117CD-2.5 $V_{in} = 4.5V, 10mA \leq I_{out} \leq 1A$		10	18	mV
		AMS1117CD-3.3 $V_{in} = 5.3V, 0 \leq I_{out} \leq 1A$		12	20	mV
		AMS1117CD-5.0 $V_{in} = 6.5V, 0 \leq I_{out} \leq 1A$		12	20	mV
Vin-Vout	最小输入输出电压差	$\Delta V_{out}, \Delta V_{ref} = 1\%, I_{out} = 1A$			1.4	V
Ilimit	最小负载电流	AMS1117CD-ADJ			10	mA
Iq	静态电流	AMS1117CD-ADJ $V_{in} = 4.0V$			12	mA
		AMS1117CD-1.2, $V_{in} = 4.8V$			12	mA
		AMS1117CD-1.5, $V_{in} = 4.8V$			12	mA
		AMS1117CD-1.8, $V_{in} = 4.8V$			12	mA
		AMS1117CD-2.5, $V_{in} = 4.8V$			12	mA
		AMS1117CD-3.3, $V_{in} = 4.8V$			12	mA
		AMS1117CD-5.0, $V_{in} = 4.8V$			12	mA

PACKAGE MECHANICAL DATA

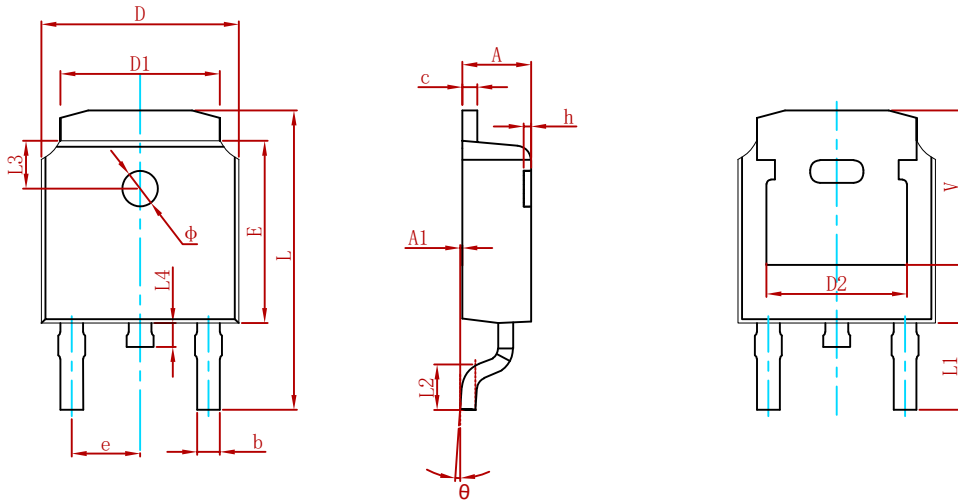

Symbol	Dimensions In Millimeters		Dimensions In Inches	
	Min.	Max.	Min.	Max.
A	2.200	2.400	0.087	0.094
A1	0.000	0.127	0.000	0.005
b	0.635	0.770	0.025	0.030
c	0.460	0.580	0.018	0.023
D	6.500	6.700	0.256	0.264
D1	5.100	5.460	0.201	0.215
D2	4.830 REF.		0.190 REF.	
E	6.000	6.200	0.236	0.244
e	2.186	2.386	0.086	0.094
L	9.712	10.312	0.382	0.406
L1	2.900 REF.		0.114 REF.	
L2	1.400	1.700	0.055	0.067
L3	1.600 REF.		0.063 REF.	
L4	0.600	1.000	0.024	0.039
φ	1.100	1.300	0.043	0.051
θ	0°	8°	0°	8°
h	0.000	0.300	0.000	0.012
V	5.250 REF.		0.207 REF.	

Suggested Pad Layout

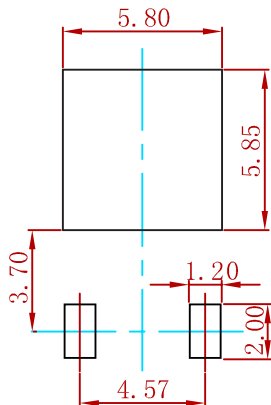

- Note:
1. Controlling dimension: in millimeters.
 2. General tolerance: ± 0.05mm.
 3. The pad layout is for reference purposes only.

REEL SPECIFICATION

P/N	PKG	QTY
AMS1117CD	TO-252	2500

Attention

- Any and all MSKSEMI Semiconductor products described or contained herein do not have specifications that can handle applications that require extremely high levels of reliability, such as life-support systems, aircraft's control systems, or other applications whose failure can be reasonably expected to result in serious physical and/or material damage. Consult with your MSKSEMI Semiconductor representative nearest you before using any MSKSEMI Semiconductor products described or contained herein in such applications.
- MSKSEMI Semiconductor assumes no responsibility for equipment failures that result from using products at values that exceed, even momentarily, rated values (such as maximum ratings, operating condition ranges, or other parameters) listed in products specifications of any and all MSKSEMI Semiconductor products described or contained herein.
- Specifications of any and all MSKSEMI Semiconductor products described or contained herein stipulate the performance, characteristics, and functions of the described products in the independent state, and are not guarantees of the performance, characteristics, and functions of the described products as mounted in the customer's products or equipment. To verify symptoms and states that cannot be evaluated in an independent device, the customer should always evaluate and test devices mounted in the customer's products or equipment.
- MSKSEMI Semiconductor strives to supply high-quality high-reliability products. However, any and all semiconductor products fail with some probability. It is possible that these probabilistic failures could give rise to accidents or events that could endanger human lives, that could give rise to smoke or fire, or that could cause damage to other property. When designing equipment, adopt safety measures so that these kinds of accidents or events cannot occur. Such measures include but are not limited to protective circuits and error prevention circuits for safe design, redundant design, and structural design.
- In the event that any or all MSKSEMI Semiconductor products (including technical data, services) described or contained herein are controlled under any of applicable local export control laws and regulations, such products must not be exported without obtaining the export license from the authorities concerned in accordance with the above law.
- No part of this publication may be reproduced or transmitted in any form or by any means, electronic or mechanical, including photocopying and recording, or any information storage or retrieval system, or otherwise, without the prior written permission of MSKSEMI Semiconductor.
- Information (including circuit diagrams and circuit parameters) herein is for example only ; it is not guaranteed for volume production. MSKSEMI Semiconductor believes information herein is accurate and reliable, but no guarantees are made or implied regarding its use or any infringement of intellectual property rights or other rights of third parties.
- Any and all information described or contained herein are subject to change without notice due to product/technology improvement, etc. When designing equipment, refer to the "Delivery Specification" for the MSKSEMI Semiconductor product that you intend to use.