

SURGING

紹 鑫 實 業



SurgeArresters

陶瓷气体放电管

X5 Series

Gas Discharge Tubes - X5 Series

Description

X5 Gas Discharge Tubes (GDT) series provides high levels of protection against fast rising transients caused by lightning disturbances. Offered in a miniature surface mount package, it has a surge rating of 3KA/2kA 8/20 μ s.

X5 GDTs are high voltage (1000-3600V) components designed for surge protection and high isolation applications. It is also suitable for applications for which bias voltage or signal levels of several hundred volts are normally present.

X5 GDTs can be used in conjunction with MOVs (Metal Oxide Varistors) to provide superior protection performance for AC applications.



Electrical symbol

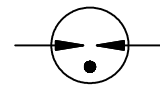

Features

- | Voltage Ranges 1000V to 3600V
- | Excellent response to fast rising transients
- | 8/20 μ s Impulse current capability: 3KA/2kA
- | Non-Radioactive
- | Ultra Low capacitance (<0.8pF)
- | Lead-free compliant
- | RoHS and REACH compliant
- | Size: 4.2mm*5mm*5mm
- | Storage and operational temperature: -40~+90°C

Applications

- | | |
|---------------------------|------------------|
| Automotive: | Others: |
| On-board chargers | LED lighting |
| Vehicle charging stations | Power supply |
| | Photovoltaic |
| | Air conditioning |

Part Numbering

X5 - 90X SMDT

Series:

X5系列: ϕ 5* 5 * 4.2
S5系列: ϕ 5*5

DCLineVoltage:

90X=90V
102X=1000V

Paclage:

SMD= Cylinder No Lead
SMDT=2-SMD Cylinder Square End

Gas Discharge Tubes - X5 Series

Electrical Characteristics

Part Number	DC Spark-over Voltage ^{1) 2)} @100V/S	Impulse Spark-over Voltage		Insulation Resistance ³⁾	Capacitance @1MHz	Glow Voltage @10mA	Arc Voltage @1A	AC withstand voltage @5mA 1Min	Life Ratings		
		100V/μS	1KV/μS						Impulse Discharge Current @8/20μS		AC Discharge Current @50Hz 1S
		Max	Max						Min	Max	Nominal 5 times
		V	V						GΩ	pF	V
X5-102XSMDT	1000±20%	1600	1800	1	0.8	160	15	500	3	4	3
X5-122XSMDT	1200±20%	1800	2000	1	0.8	160	15	600	3	4	3
X5-152XSMDT	1500±20%	2300	2500	1	0.8	235	15	750	2	3	2
X5-202XSMDT	2000±20%	2800	3000	1	0.8	260	20	1000	2	3	2
X5-252XSMDT	2500±20%	3300	3600	1	0.8	260	20	1300	2	3	2
X5-272XSMDT	2700±20%	3500	3800	1	0.8	260	20	1400	2	3	2
X5-302XSMDT	3000±20%	3800	4000	1	0.8	260	20	1600	2	3	2
X5-362XSMDT	3600±20%	4700	5000	1	0.8	260	20	1900	2	3	2
Glow to Arc transition Current.....					~0.3A						
Weight.....					~0.42g						
Operation and storage temperature.....					-40~+90°C						
Climatic category (IEC 60068-1).....					40/90/21						
Marking.....					Without						
Surface treatment.....					Matte-tin plated						

¹⁾ At delivery AQL 0.65 level II, DIN ISO 2859.

²⁾ In ionized mode.

³⁾ Insulation Resistance Measuring Voltage at DC 100V.

Terms in accordance with ITU-T Rec. K.12, IEC 61643-311, GB/T 9043.

Gas Discharge Tubes - X5 Series

Dimensions

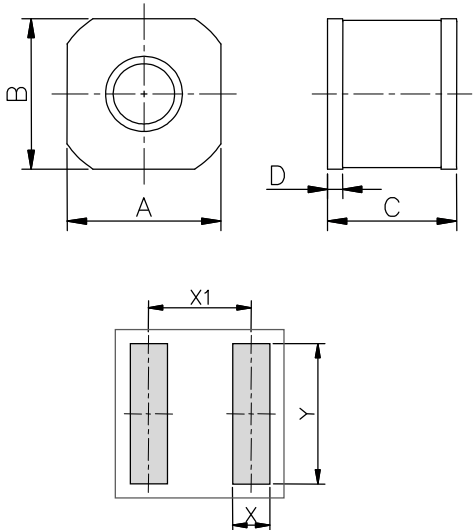

Recommended Soldering Pad Layout

Symbol	Millimeters	Inches
A	5.0±0.2	0.197±0.008
B	5.0±0.2	0.197±0.008
C	4.2±0.3	0.165±0.012
D	0.5±0.1	0.020±0.004
X	1.2	0.047
X1	4.0	0.165
Y	5.5	0.217

Taping and Reel Specifications

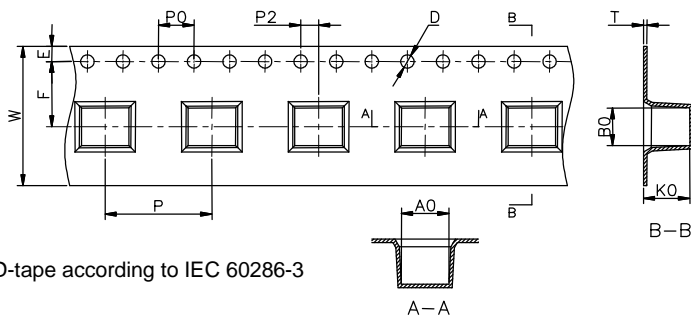

SMD-tape according to IEC 60286-3

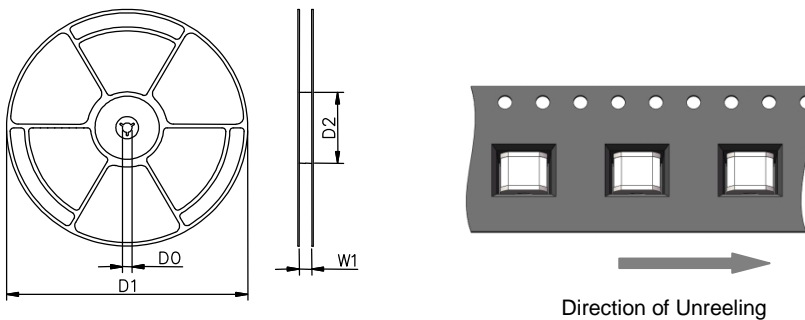

Direction of Unreeling

Symbol	Millimeters	Inches
W	16±0.3	0.630±0.012
A0	5.3±0.1	0.209±0.004
B0	4.3±0.1	0.17±0.004
K0	5.2±0.1	0.205±0.004
P	12±0.1	0.472±0.004
F	7.5±0.1	0.295±0.004
E	1.75±0.1	0.069±0.004
D	1.5+0.1/-0.0	0.059+0.004/-0.0
P0	4±0.1	0.157±0.004
P2	2±0.1	0.079±0.004
T	0.4±0.1	0.016±0.004
D0	13.3±0.15	0.524±0.006
D1	330±2	12.992±0.079
D2	100+1/-2	3.937+0.039/-0.079
W1	16.5±0.4	0.65±0.016

Packaging Quantity:

- 1,000 PCS per reel (13")
- 3 reels per inner box
- 3,000 PCS per inner box

Gas Discharge Tubes - X5 Series

Soldering Parameters - Reflow Soldering (Surface Mount Devices)

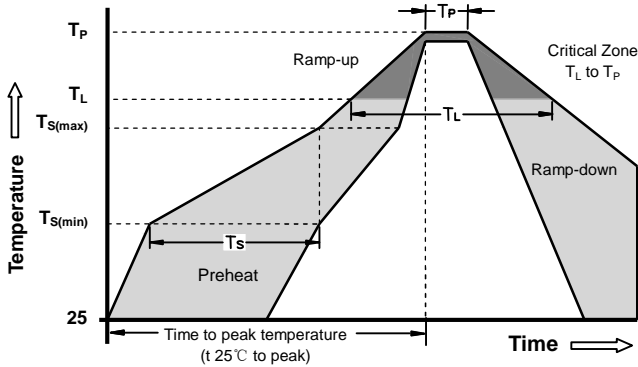

Reflow Condition		Pb - Free assembly
Pre Heat	-Temperature Min ($T_{s(min)}$)	150°C
	-Temperature Max ($T_{s(max)}$)	200°C
	- Time (min to max) (t_s)	60 -180 Seconds
Average ramp up rate (Liquids Temp T_L to peak)		3°C/second max
$T_{s(max)}$ to T_L - Ramp-up Rate		5°C/second max
Reflow	- Temperature (T_L) (Liquids)	217°C
	- Time (min to max) (t_s)	60 -150 Seconds
Peak Temperature (T_P)		260 +0/-5°C
Time within 5°C of actual peak Temperature (t_p)		10 - 30 Seconds
Ramp-down Rate		6°C/second max
Time 25°C to peak Temperature (T_P)		8 minutes Max
Do not exceed		260°C