

Specifications:  
 规格:  
 Voltage rating:125V AC/DC  
 额定电压: 125V AC/DC  
 Current rating:1A AC/DC  
 额定电流: 1A AC/DC  
 Withstanding voltage:500V AC/minute  
 耐受电压: 500V AC/分钟  
 Temperature range:-25℃~+105℃  
 温度范围: -25℃~+105℃  
 Insulation resistance:≥500MΩ  
 绝缘电阻: ≥500MΩ  
 Contact resistance:≤20mΩ  
 接触电阻: ≤20mΩ

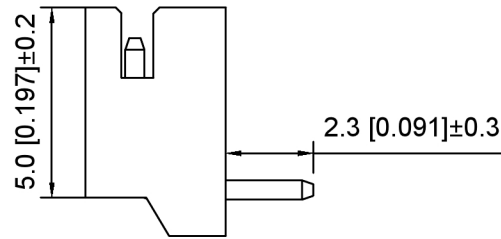

X1502 W R - XX R - LP SN  
 ① ② ③ ④ ⑤ ⑥ ⑦

- 1.Series No
- 2.Category:W-Wafer
- 3.Welding Board Angle:R-Stright 90°
- 4.Row No.Pin No:XX-02~16Pin
- 5.Special No:R-DIP 2.3mm
- 6.Material:LP-LCP UL94V-0 ,Natural
- 7.Plating:SN- Tin Plated

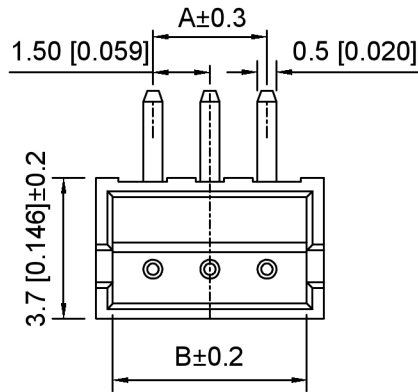
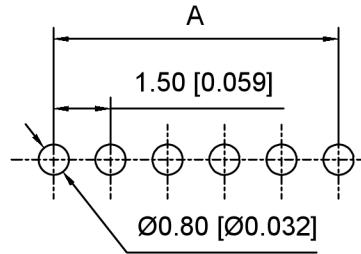
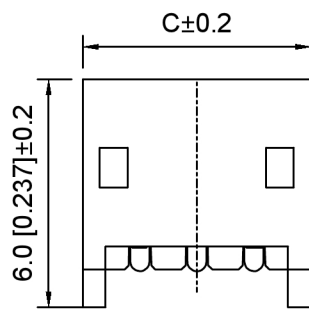

Recommended PCB Layout(Top view)  
 Tolerance:±0.05mm

Poles	Dimensions (mm)			Poles	Dimensions (mm)		
	A	B	C		A	B	C
02	1.50	3.60	4.50	10	13.50	15.60	16.50
03	3.00	5.10	6.00	11	15.00	17.10	18.00
04	4.50	6.60	7.50	12	16.50	18.60	19.50
05	6.00	8.10	9.00	13	18.00	20.10	21.00
06	7.50	9.60	10.50	14	19.50	21.60	22.50
07	9.00	11.10	12.00	15	21.00	23.10	24.00
08	10.50	12.60	13.50	16	22.50	24.60	25.50
09	12.00	14.10	15.00				

X1502WR-XXR-LPSN	LCP	Brass	X1502H
PART NO	Material	Material(Pin)	Suitable XKB Housing

广东星坤科技股份有限公司

MARK	DESCRIPTION	DATE	REVISED	APPROVED
ΔX		日期		
ΔX				
Δ效				

REVISIONS	UNSPECIFIED TOLERANCES
ANGLAR ±5°	
L≤ 4 ±0.2	
4<L≤ 16 ±0.3	
16<L≤ 63 ±0.4	
L> 63 ±0.5	



XKB INDUSTRIAL PRECISION CO.,LIMITED

DSND	SCALE: N/A	MODEL TYPE: 1.5mm Crimp Style Connector
DWN	VIEW:	PART NO.: X1502WR-XXR-LPSN
CHKD	UNIT: mm/in	DWG NO.: X-X1502WR-XXR-LPSN
APPD	SIZE: A4	
		WEIGHT SHEET REVISION 1/1 A0

文件工程章