

NOTES1:

- UL Standard
- 1. Rated voltage/current : 300V / 10A
- 2. Withstanding voltage : AC1600V/1Min.
- 3. Wire range : 24~16AWG

IEC Standard

1. Pollution degree	2	2	3
Overvoltage category	II	III	III
Rate impulse voltage(KV)	2.5KV	2.5KV	2.5KV
Rate voltage(V)	400V	200V	160V
Rate current(A)	17.5A		

2. Wire range : 0.2~1.5mm²

NOTES2:

- 1. Dimension shall be interpreted per ASME Y14.5-2009
- 2. Pitch : 3.50mm, Poles : N=01~24P
- 3. Stripping length : 10mm
- 4. Operating temperature: -40°C~+105°C
- 5. Undimensioned tolerances:

Pitch range in mm	Nominal dimension range in mm					
	Over	Over	Over	Over	Over	Over
6	10	30	60	100	150	0.1/10
TO	10	TO	TO	TO	TO	<
6	10	24	30	60	100	150
±0.15/±0.20/±0.30/±0.30/±0.50/±0.70/±1.00/±1.30						±2°

6. RoHS Compliance

Ordering Information

JL271V - 350 XX G 0 1

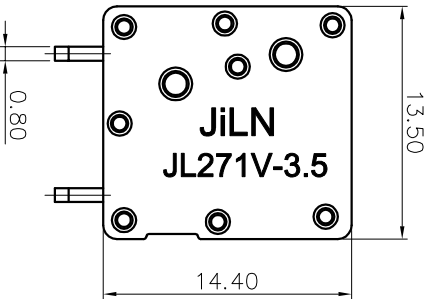
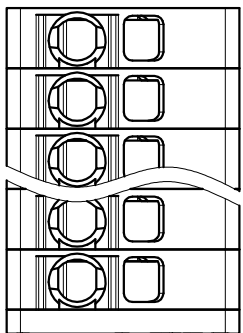
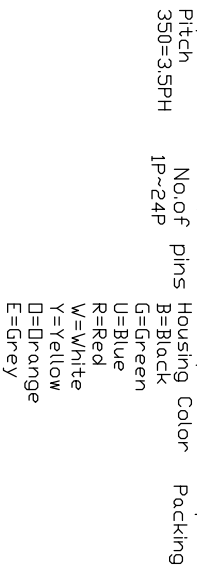

REVISION RECORD			
REV	ECN	DESCRIPTION	DATE
A		NEW	22.06.30

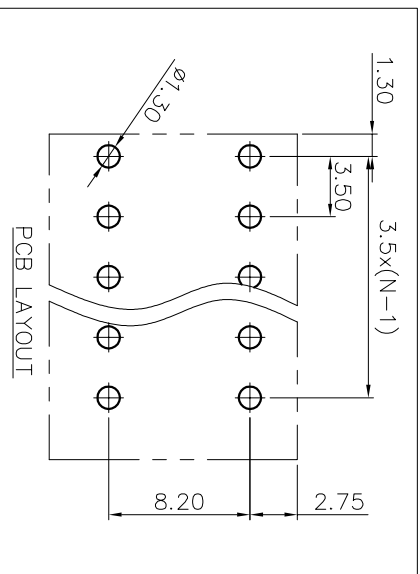
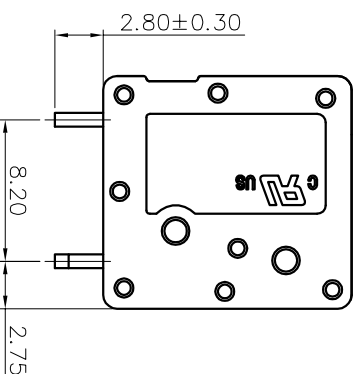
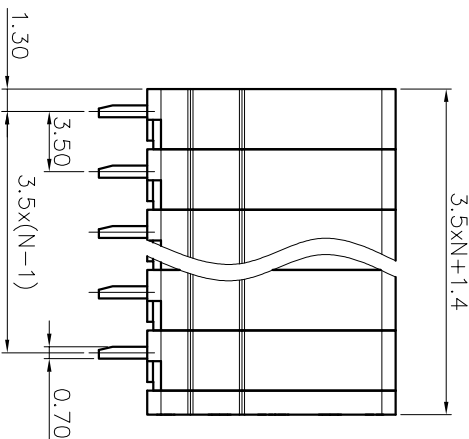

DRAW	SHUANGPING ZHENG	SCALE	FIT	<p>JIN 东莞市锦凌电子有限公司 DONGGUAN JINLING ELECTRONIC CO., LTD</p>
CHECK	LICHAD LIU	UNIT	mm	
APPROVE	YONGLIANG GAO	SIZE	A4	
		SHEET	1/1	PART NO.
		PRD		JL271V-350XXG01
				TITLE:
				JL271V-3.5-XXP 弹簧式/直脚/双排/绿色