

# Engineer Drawing

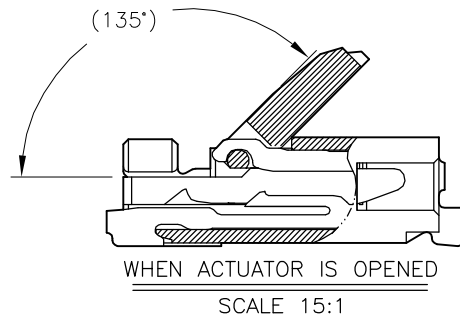
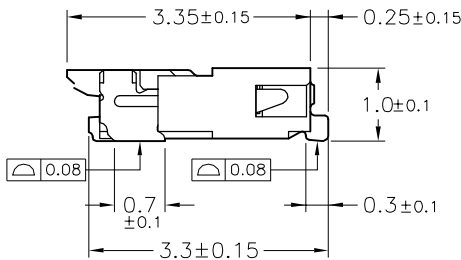
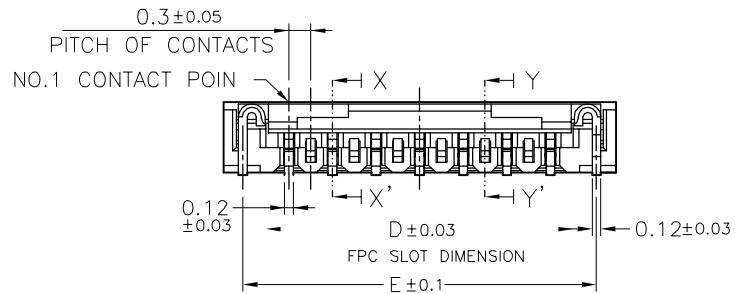
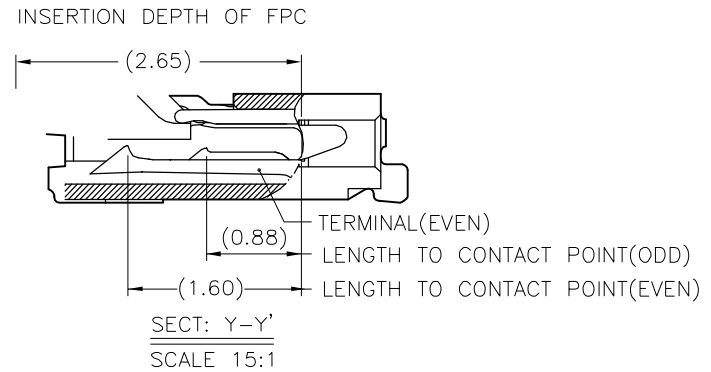
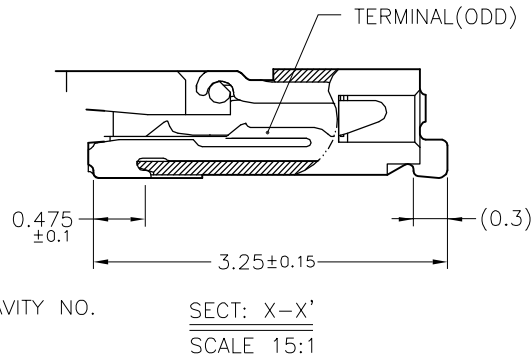
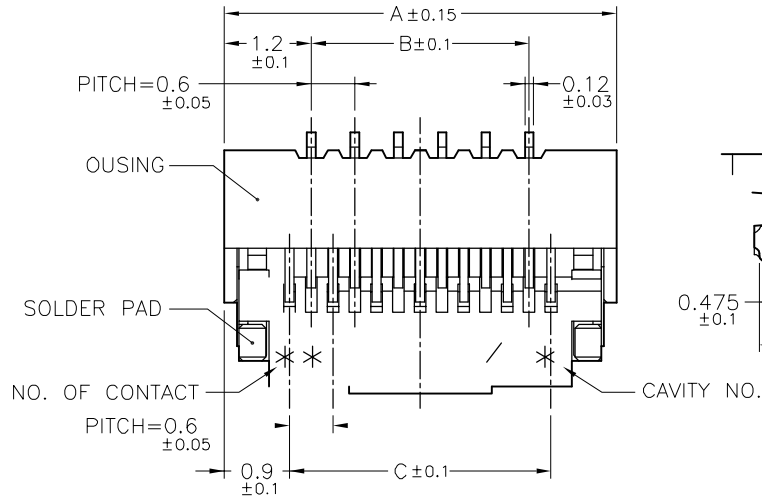

**NOTE:**

- 1.MATERIAL:  
 HOUSING:LCP(UL 94V-0)  
 ACTUATOR:LCP(UL 94V-0)  
 TERMINAL:PHOSPHOR BRONZE  
 STOPPER:PHOSPHOR BRONZE
- 2.PLATING:  
 TERMINAL:SEE ORDERING INFORMATION  
 STOPPER:TIN OVER NICKEL(LEAD FREE)
- 3.RATING:  
 OPERATING VOLTAGE:30V  
 CURRENT RATING:0.2A  
 OPERATING TEMPERATURE:-55°C ~ +85°C

IPFP03101 \*\* \* \* \* \*  
 ① ② ③ ④ ⑤ ⑥

- ① Series Type
- ② Pin code.
- ③ Plating
- ④ Company code.
- ⑤ Packing
- ⑥ Lead Free HF

NO. OF CONTACTS	PART NUMBER	DIM. A	DIM. B	DIM. C	DIM. D	DIM. E
09	09RL	4.2	1.8	2.4	3.03	3.7
11	11RL	4.8	2.4	3.0	3.63	4.3
13	13RL	5.4	3.0	3.6	4.23	4.9
15	15RL	6.0	3.6	4.2	4.83	5.5
17	17RL	6.6	4.2	4.8	5.43	6.1
19	19RL	7.2	4.8	5.4	6.03	6.7
21	21RL	7.8	5.4	6.0	6.63	7.3
23	23RL	8.4	6.0	6.6	7.23	7.9
25	25RL	9.0	6.6	7.2	7.83	8.5
27	27RL	9.6	7.2	7.8	8.43	9.1
29	29RL	10.2	7.8	8.4	9.03	9.7
31	31RL	10.8	8.4	9.0	9.63	10.3
33	33RL	11.4	9.0	9.6	10.23	10.9
35	35RL	12.0	9.6	10.2	10.83	11.5
37	37RL	12.6	10.2	10.8	11.43	12.1
39	39RL	13.2	10.8	11.4	12.03	12.7
41	41RL	13.8	11.4	12.0	12.63	13.3
43	43RL	14.4	12.0	12.6	13.23	13.9
45	45RL	15.0	12.6	13.2	13.83	14.5
49	49RL	16.2	13.8	14.4	15.03	15.7
51	51RL	16.8	14.4	15.0	15.63	16.3
57	57RL	18.6	16.2	16.8	17.43	18.1
61	61RL	19.8	17.4	18.0	18.63	19.3
67	67RL	21.6	19.2	19.8	20.43	21.1
71	71RL	22.8	20.4	21.0	21.63	22.3

**TOLERANCE**

$X \pm 0.5$     $XX \pm 0.12$   
 $X \pm 0.25$     $XXX \pm 0.05$   
 ANGLES    $\pm 3^\circ$



[www.i-ncp.com](http://www.i-ncp.com)

PART NO.  
 IPFP03101 xx  
 DRAWING NO.  
 IPFP03101

TITLE:  
0.3mm Pitch FPC Conn E/O (H=1.0)

UNLESS OTHERWISE SPECIFIED



SHEET 1 OF 3

UNITS mm

SCALE 1:1

REV. 01

# Engineer Drawing

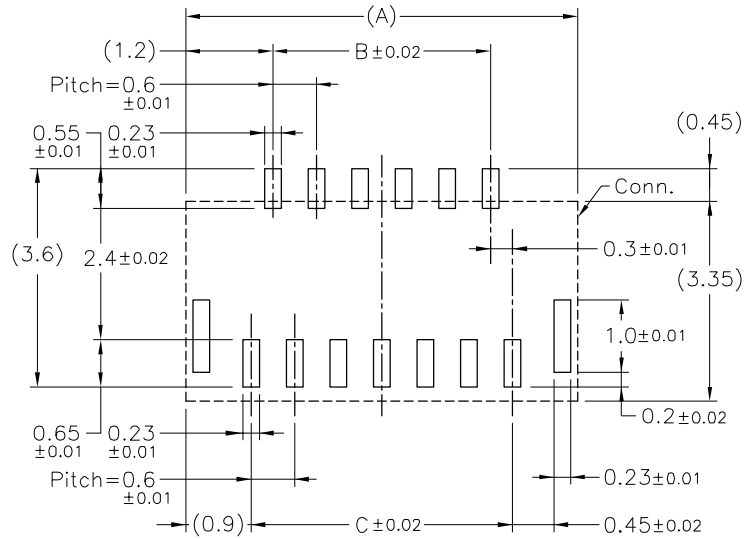

## RECOMMENDED METAL MASK PATTERN

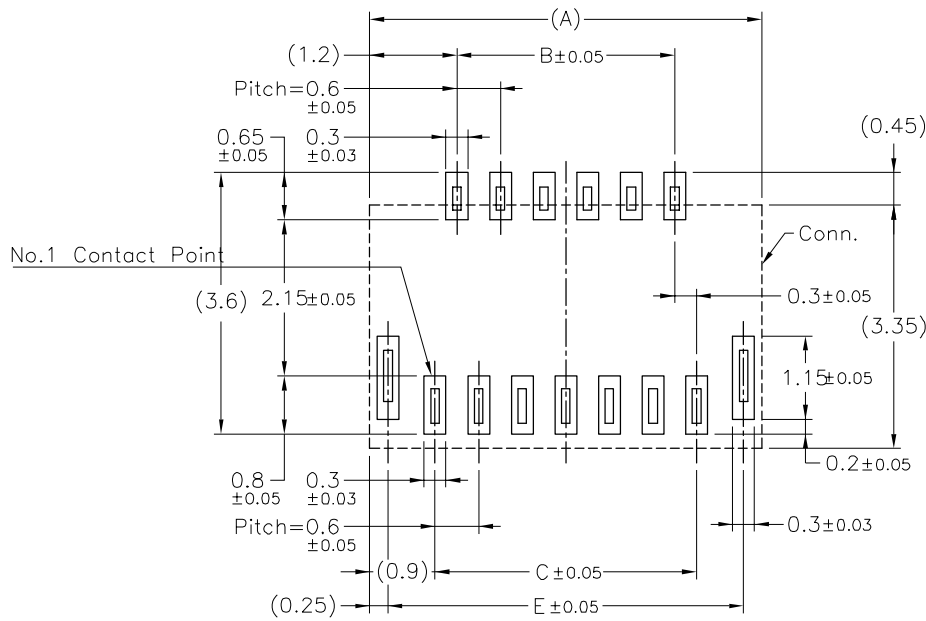

FPC/FFC INSERT DIRECTION  
PCB LAYOUT

NO. OF CONTACTS	PART NUMBER	DIM. A	DIM. B	DIM. C	DIM. E
09	09RL	4.2	1.8	2.4	3.7
11	11RL	4.8	2.4	3.0	4.3
13	13RL	5.4	3.0	3.6	4.9
15	15RL	6.0	3.6	4.2	5.5
17	17RL	6.6	4.2	4.8	6.1
19	19RL	7.2	4.8	5.4	6.7
21	21RL	7.8	5.4	6.0	7.3
23	23RL	8.4	6.0	6.6	7.9
25	25RL	9.0	6.6	7.2	8.5
27	27RL	9.6	7.2	7.8	9.1
29	29RL	10.2	7.8	8.4	9.7
31	31RL	10.8	8.4	9.0	10.3
33	33RL	11.4	9.0	9.6	10.9
35	35RL	12.0	9.6	10.2	11.5
37	37RL	12.6	10.2	10.8	12.1
39	39RL	13.2	10.8	11.4	12.7
41	41RL	13.8	11.4	12.0	13.3
43	43RL	14.4	12.0	12.6	13.9
45	45RL	15.0	12.6	13.2	14.5
49	49RL	16.2	13.8	14.4	15.7
51	51RL	16.8	14.4	15.0	16.3
57	57RL	18.6	16.2	16.8	18.1
61	61RL	19.8	17.4	18.0	19.3
67	67RL	21.6	19.2	19.8	21.1
71	71RL	22.8	20.4	21.0	22.3

### TOLERANCE

X ± 0.5    XX ± 0.12  
X ± 0.25    XXX ± 0.05  
ANGLES    ± 3'

**NCP**

[www.i-ncp.com](http://www.i-ncp.com)

PART NO.  
IPFP03101 xx  
DRAWING NO.  
IPFP03101

TITLE:  
0.3mm Pitch FPC Conn E/O (H=1.0)

UNLESS OTHERWISE SPECIFIED



SHEET 2 OF 3

UNITS mm

SCALE 1:1

REV. 01

# Engineer Drawing

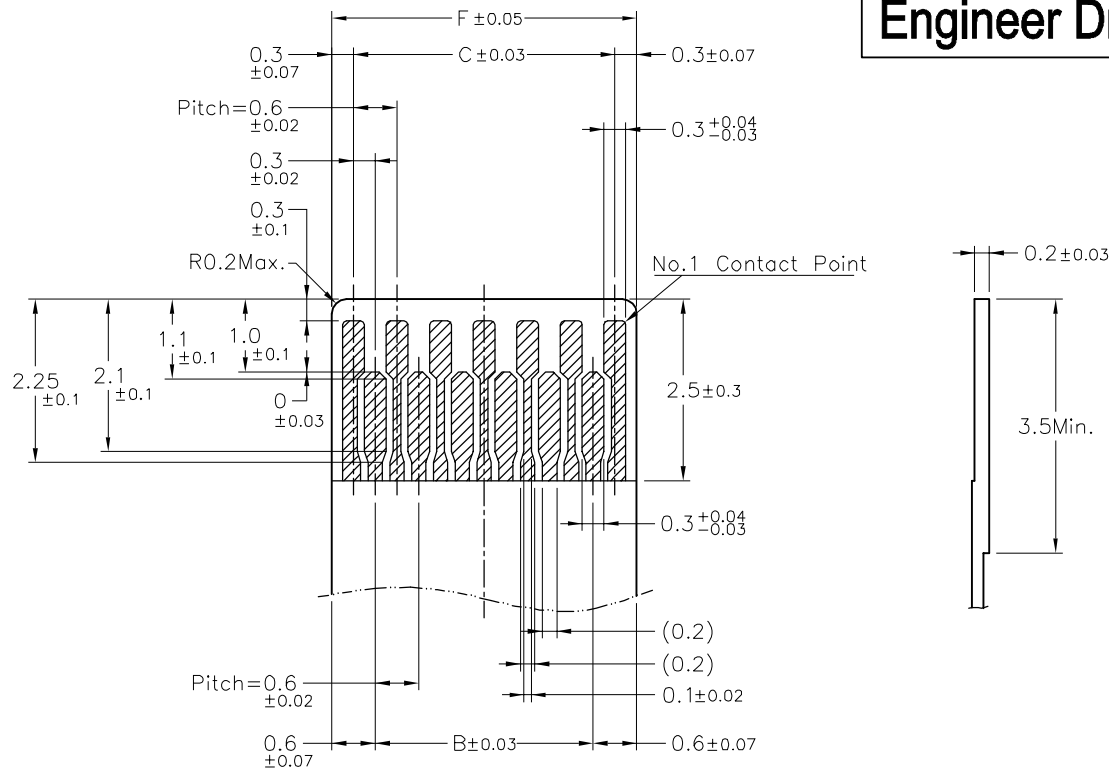

APPLICABLE FPC

NO. OF CONTACTS	PART NUMBER	DIM. A	DIM. B	DIM. C	DIM. E
09	09RL	4.2	1.8	2.4	3.7
11	11RL	4.8	2.4	3.0	4.3
13	13RL	5.4	3.0	3.6	4.9
15	15RL	6.0	3.6	4.2	5.5
17	17RL	6.6	4.2	4.8	6.1
19	19RL	7.2	4.8	5.4	6.7
21	21RL	7.8	5.4	6.0	7.3
23	23RL	8.4	6.0	6.6	7.9
25	25RL	9.0	6.6	7.2	8.5
27	27RL	9.6	7.2	7.8	9.1
29	29RL	10.2	7.8	8.4	9.7
31	31RL	10.8	8.4	9.0	10.3
33	33RL	11.4	9.0	9.6	10.9
35	35RL	12.0	9.6	10.2	11.5
37	37RL	12.6	10.2	10.8	12.1
39	39RL	13.2	10.8	11.4	12.7
41	41RL	13.8	11.4	12.0	13.3
43	43RL	14.4	12.0	12.6	13.9
45	45RL	15.0	12.6	13.2	14.5
49	49RL	16.2	13.8	14.4	15.7
51	51RL	16.8	14.4	15.0	16.3
57	57RL	18.6	16.2	16.8	18.1
61	61RL	19.8	17.4	18.0	19.3
67	67RL	21.6	19.2	19.8	21.1
71	71RL	22.8	20.4	21.0	22.3

**TOLERANCE**

X ± 0.5 XX ± 0.12  
 X ± 0.25 .XXX ± 0.05  
 ANGLES ± 3'

UNLESS OTHERWISE SPECIFIED



[www.i-ncp.com](http://www.i-ncp.com)

PART NO.  
IPFP03101 xx  
 DRAWING NO.  
IPFP03101

TITLE:  
0.3mm Pitch FPC Conn E/O (H=1.0)



SHEET 3 OF 3

UNITS mm

SCALE 1:1

REV. 01