

FH3704B
N-Channel Trench Power MOSFET
Description

These N Channel enhancement mode power field effect transistors are using trench DMOS technology. This advanced technology has been especially tailored to minimize on-state resistance, provide superior switching performance, and with stand high energy pulse in the avalanche and commutation mode. These devices are well suited for high efficiency fast switching applications.

Features

- ◆ 40V,170A, $R_{DS(on).max}=3.5m\Omega@V_{GS} = 10V$
- ◆ Improved dv/dt capability
- ◆ Fast switching
- ◆ 100% EAS Guaranteed
- ◆ Green device available

Applications

- ◆ Motor Drives
- ◆ UPS
- ◆ DC-DC Converter

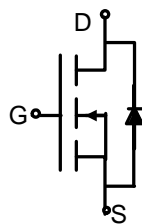

Schematic diagram

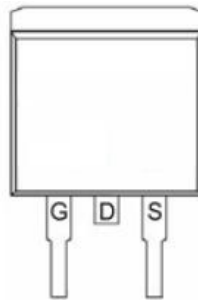
TO-263

Marking and pin assignment

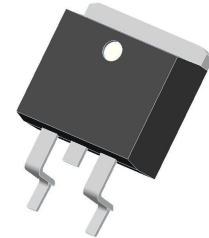

TO-263 top view

Absolute Maximum Ratings $T_C = 25^\circ\text{C}$ unless otherwise noted

Parameter	Symbol	Value	Unit
Drain-Source Voltage	V_{DSS}	40	V
Continuous drain current ($T_C = 25^\circ\text{C}$) ¹⁾	I_D	170	A
Continuous drain current ($T_C = 100^\circ\text{C}$) ¹⁾		114	A
Pulsed drain current ²⁾	I_{DM}	590	A
Gate-Source voltage	V_{GSS}	± 20	V
Avalanche energy ³⁾	E_{AS}	544	mJ
Power Dissipation ($T_C = 25^\circ\text{C}$)	P_D	186	W
Storage Temperature Range	T_{STG}	-55 to +150	$^\circ\text{C}$
Operating Junction Temperature Range	T_J	-55 to +150	$^\circ\text{C}$

Thermal Characteristics

Parameter	Symbol	Value	Unit
Thermal Resistance, Junction-to-Case	$R_{\theta JC}$	0.88	$^\circ\text{C/W}$
Thermal Resistance, Junction to Ambient	$R_{\theta JA}$	62.5	$^\circ\text{C/W}$

Electrical Characteristics

 $T_J = 25^\circ\text{C}$ unless otherwise noted

Parameter	Symbol	Test Condition	Min.	Typ.	Max.	Unit
Static characteristics						
Drain-source breakdown voltage	BV_{DSS}	$V_{GS}=0\text{ V}, I_D=250\mu\text{A}$	40	---	--	V
Gate threshold voltage	$V_{GS(th)}$	$V_{DS}=V_{GS}, I_D=250\mu\text{A}$	1.3		2.5	V
Drain source leakage current	I_{DSS}	$V_{DS}=40\text{ V}, V_{GS}=0\text{ V}, T_J = 25^\circ\text{C}$	---	---	1	μA
		$V_{DS}=40\text{ V}, V_{GS}=0\text{ V}, T_J = 125^\circ\text{C}$	---	---	5	μA
Gate leakage current Forward	I_{GSSF}	$V_{GS}=20\text{ V}, V_{DS}=0\text{ V}$			100	nA
Gate leakage current Reverse	I_{GSSR}	$V_{GS}=-20\text{ V}, V_{DS}=0\text{ V}$	---	---	-100	nA
Drain source on state resistance	$R_{DS(on)}$	$V_{GS}=10\text{ V}, I_D=20\text{ A}$		2.5	3.5	$\text{m}\Omega$
		$V_{GS}=4.5\text{ V}, I_D=10\text{ A}$	---	3.5	6.0	$\text{m}\Omega$
Forward transconductance	g_{fs}	$V_{DS}=5\text{ V}, I_D=50\text{A}$	26	---	---	S
Dynamic characteristics						
Input capacitance	C_{iss}	$V_{DS} = 20\text{ V}, V_{GS} = 0\text{ V},$ $F = 1\text{MHz}$		7810		pF
Output capacitance	C_{oss}			677		
Reverse transfer capacitance	C_{rss}			370		
Turn on delay time	$t_{d(on)}$	$V_{DD} = 20\text{V}, V_{GS}=10\text{V}, I_D = 20\text{ A}$		15		ns
Rise time	t_r		---	17	---	
Turn-off delay time	$t_{d(off)}$		---	52	---	
Fall time	t_f			23		
Gate resistance	R_g	$V_{GS}=0\text{V}, V_{DS}=0\text{V}, F=1\text{MHz}$	---	2.12	---	Ω
Gate charge characteristics						
Gate to source charge	Q_{gs}	$V_{DS}=20\text{ V}, I_D=100\text{A},$ $V_{GS}=10\text{ V}$	---	36.4	---	nC
Gate to drain charge	Q_{gd}		---	37.3	---	
Gate charge total	Q_g		---	139	---	
Drain-Source diode characteristics and Maximum Ratings						
Continuous Source Current	I_S		---	---	170	A
Pulsed Source Current ⁴⁾	I_{SM}		---	---	590	A
Diode Forward Voltage	V_{SD}	$V_{GS}=0\text{V}, I_S=50\text{A}, T_J=25^\circ\text{C}$			1.2	V
Reverse Recovery Time	t_{rr}	$I_S=100\text{A}, di/dt=100\text{A}/\mu\text{s},$		42		ns
Reverse Recovery Charge	Q_{rr}	$T_J=25^\circ\text{C}$		120		nC

Notes:

- 1: The maximum junction current rating is package limited.
- 2: Repetitive Rating: Pulse width limited by maximum junction temperature
- 3: $V_{DD}=20\text{V}, V_{GS}=10\text{V}, L=1\text{mH}, I_{AS}=33\text{A}, R_G=25\Omega,$ Starting $T_J=25^\circ\text{C}$.
- 4: Pulse Test: Pulse Width $\leq 300\mu\text{s},$ Duty Cycle $\leq 2\%$

Electrical Characteristics Diagrams

Figure 1. Typ. Output Characteristics

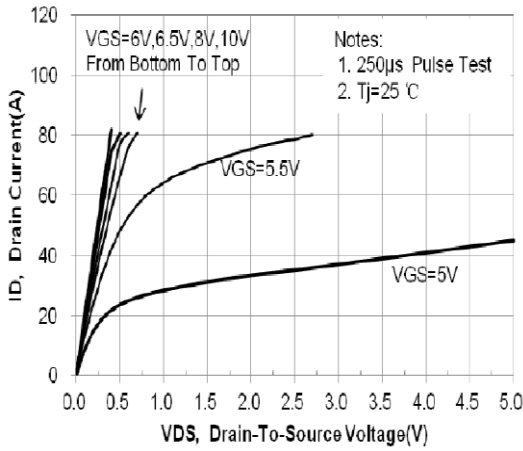

Figure 2. Transfer Characteristics

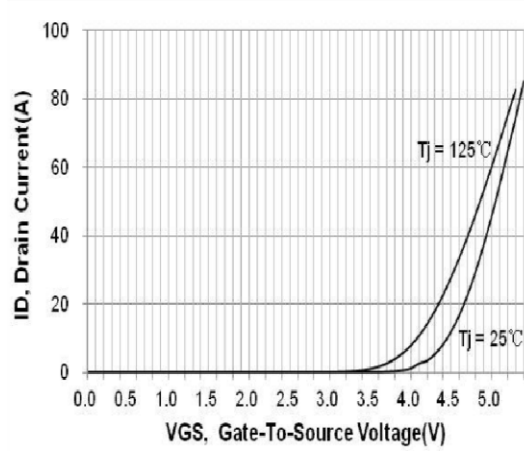

Figure 3. Capacitance Characteristics

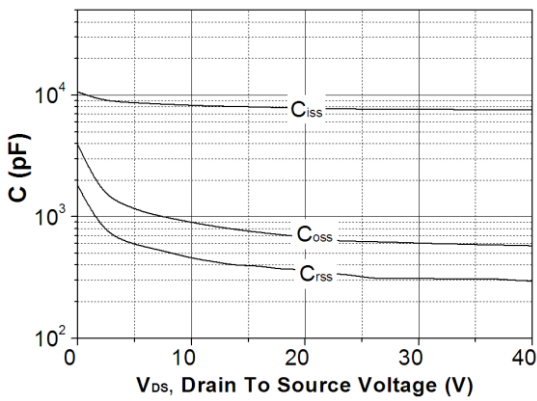

Figure 4. Gate Charge Waveform

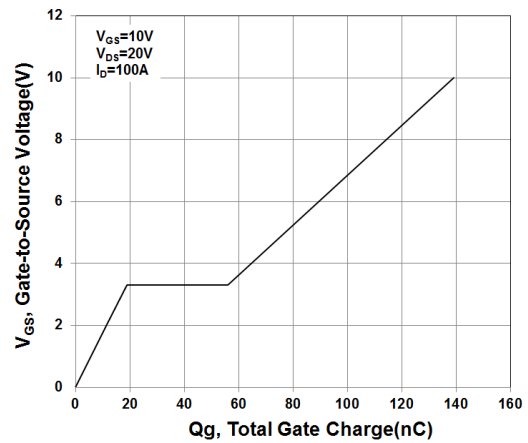

Figure 5. Body-Diode Characteristics

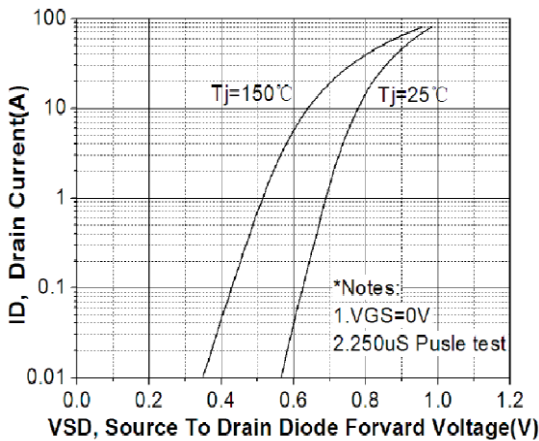

Figure 6. Normalized Maximum Transient Thermal Impedance (RthJC)

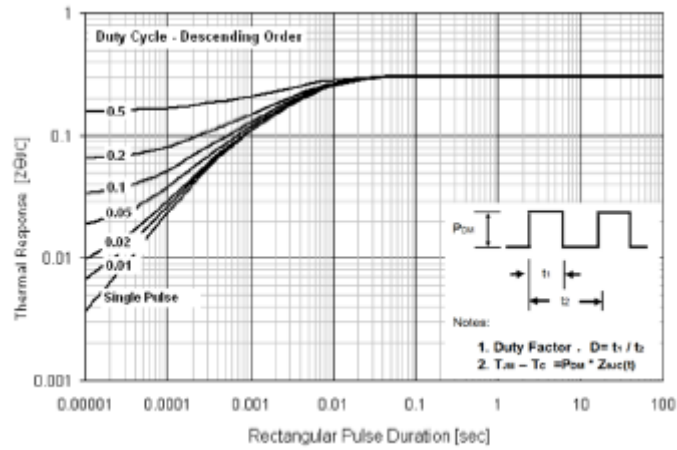
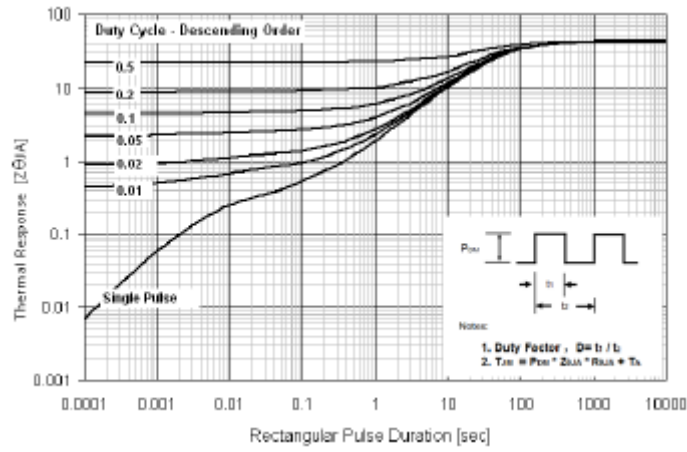

Figure 7. Normalized Maximum Transient Thermal Impedance (RthJA)



Test Circuit & Waveform

Figure 8. Gate Charge Test Circuit & Waveform

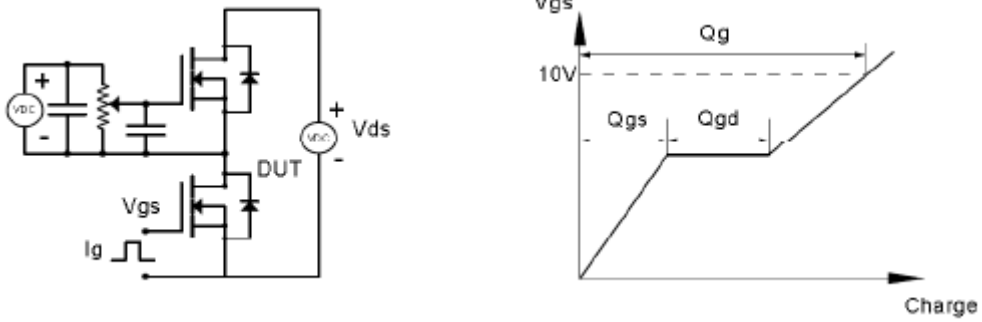

Figure 9. Resistive Switching Test Circuit & Waveforms

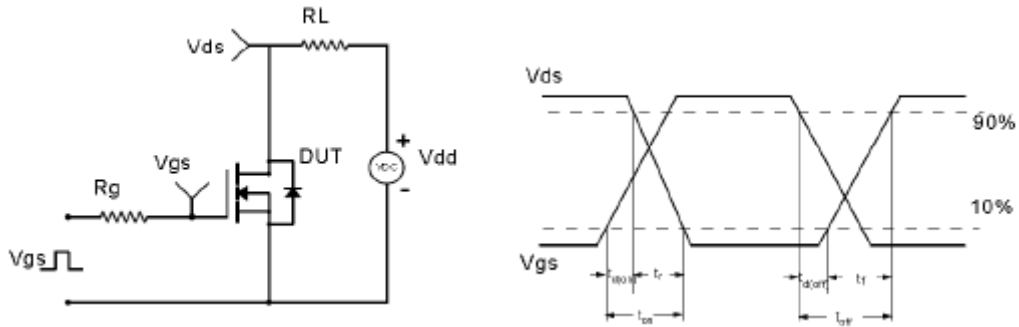

Figure 10. Unclamped Inductive Switching (UIS) Test Circuit & Waveform

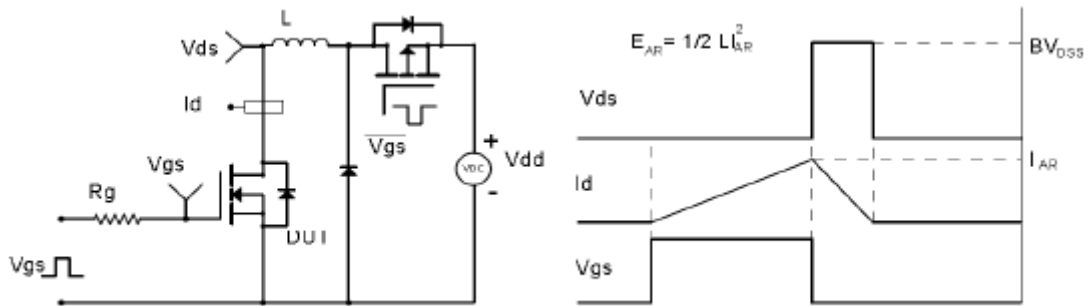
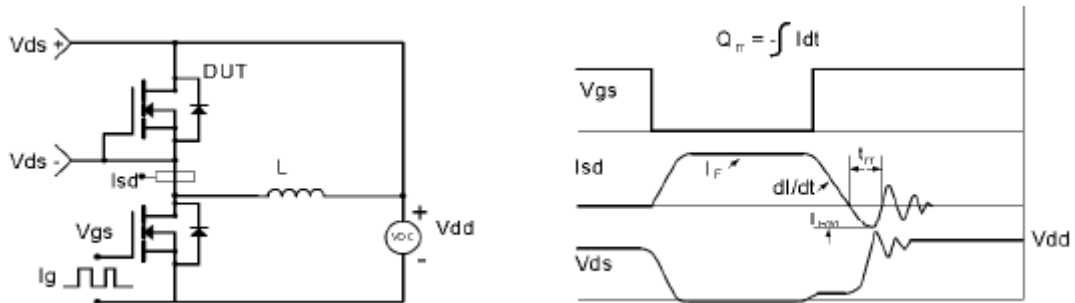
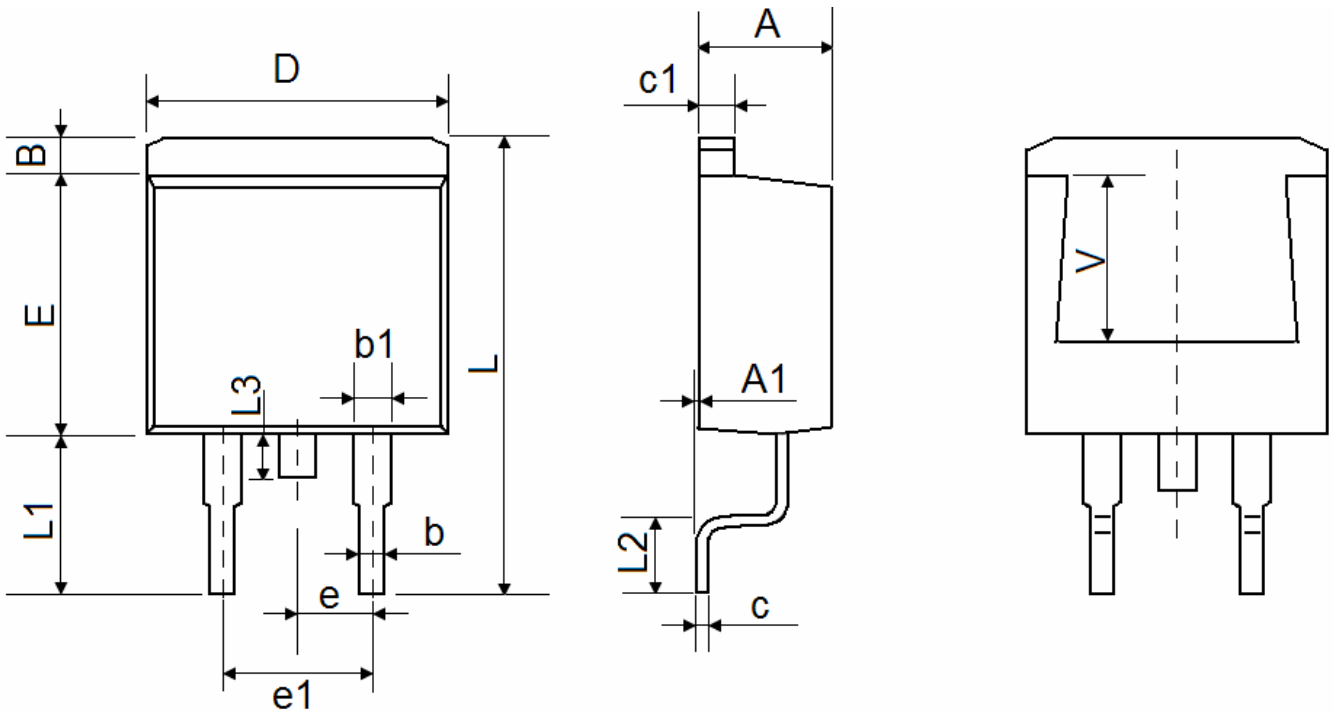

Figure 11. Diode Recovery Circuit & Waveform



Package Information : TO-263



Symbol	Dimensions In Millimeters		Dimensions In Inches	
	Min.	Max.	Min.	Max.
A	4.470	4.670	0.176	0.184
A1	0.000	0.150	0.000	0.006
B	1.170	1.370	0.046	0.054
b	0.710	0.910	0.028	0.036
b1	1.170	1.370	0.046	0.054
c	0.310	0.530	0.012	0.021
c1	1.170	1.370	0.046	0.054
D	10.010	10.310	0.394	0.406
E	8.500	8.900	0.335	0.350
e	2.540 TYP.		0.100 TYP.	
e1	4.980	5.180	0.196	0.204
L	15.050	15.450	0.593	0.608
L1	5.080	5.480	0.200	0.216
L2	2.340	2.740	0.092	0.108
L3	1.300	1.700	0.051	0.067
V	5.600 REF		0.220 REF	