



SPECIFICATION

Surface Acoustic Wave Filter

USER



USER PART No.

WISOL PART No. **SFX733EYJ02**

DOC. No. SMS-51-L-SFT-FS-218

DATE March 24, 2019

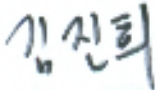
REVISION 000

WISOL					
ISSUED BY	Kim, Jin-Hee 	APPROVED BY (R&D)	Ha, Sang-Ki 	APPROVED BY (QC)	Hong, Sang-Dea 
User					
ISSUED BY		CHECKED BY		APPROVED BY	

WISOL CO., LTD.
531-7, Gajang-ro, Osan-si,
Gyeonggi-do, KOREA, 18103
<http://www.wisol.co.kr>

▶ **A TABLE OF CONTENTS**

1. REVISION HISTORY	3
2. DEFINITION	4
3. PRECAUTIONS	4
4. OUTLINE DRAWING & DIMENSIONS	5
5. MARKING	6
6. PERFORMANCE	7
6-1. MAXIMUM RATINGS	7
6-2. ELECTRICAL CHARACTERISTICS	8
7. RELIABILITY	13
7-1. ENGINEERING SAMPLE FLOW CHART	13
7-2. TEST ITEM & CONDITION	14
8. REFLOW CONDITION	15
9. RECOMMENDED PCB DIMENSIONS	15
10. CAUTION	16
11. PACKING	17
11-1. DIMENSIONS	17
11-2. REELING QUANTITY	18
11-3. TAPING STRUCTURE	18
11-4. INNER BOX(Reel Packing) STRUCTURE	19
11-5. OUTER BOX STRUCTURE	20
12. TAPE SPECIFICATIONS	21
13. RoHS DATA	22
13-1. RAW MATERIAL(EPOXY)	22
13-2. RAW MATERIAL(PACKAGE)	30
13-3. RAW MATERIAL(LT WAFER)	34
13-4. RAW MATERIAL(GOLD WIRE)	43

1. REVISION HISTORY

000	March 24, 2019	All Page	Make specification
-----	----------------	----------	--------------------

2. DEFINITION

2-1. PART No.

S F X 7 3 3 E Y J 0 2

① ② ③ ④ ⑤ ⑥

No.	EXPLANATION
①	SAW Filter
②	Design Type
③	Center Frequency :TX(733MHz),RX(788MHz)
④	Input:50ohm,Output:50ohm
⑤	Package size: 1.8×1.4mm ²
⑥	Design Revision (02 : Molding Type)

2-2. APPLICATION : LTE B28B Duplexer

2-3. SPEC

ESD Level HBM=300V

3. PRECAUTIONS

3-1. This device should not be used in any type of fluid such as water, oil, organic solvent, etc.

3-2. This is a hermetic device.

MSL(Moisture Sensitive Level) is the '2a' level.

3-3. Ultrasonic cleaning shall be avoided.

3-4. Isopropyl Alcohol and Ethyl Alcohol can be used for cleaning. Contact us before using other cleaning solvents than above

3-5. This is an electrostatic sensitive device.

Please avoid static voltage during operation and storage.

3-6. Sudden change of temperature shall be avoided, deterioration of the characteristics can occur.

3-7. If any malfunction due to designing or manufacturing which is out of specification occurs within one year after the products have been delivered, the maker should exchange the defective products.

4. OUTLINE DRAWING & DIMENSIONS

[Unit: mm]

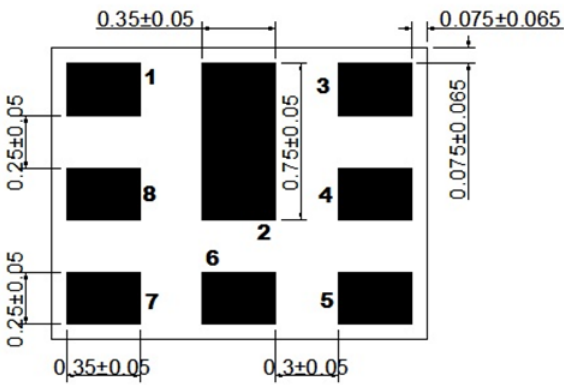
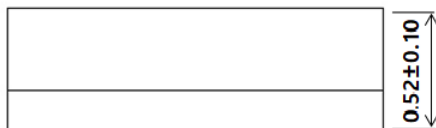
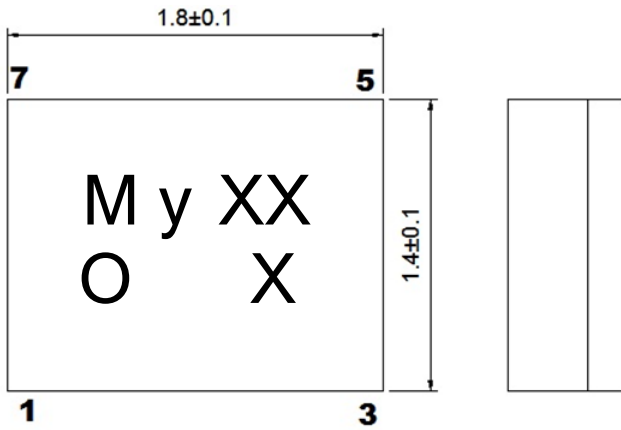

No.	Function
1	Rx Output
3	Tx Input
6	Antenna
2, 4, 5, 7, 8	Ground

5. MARKING

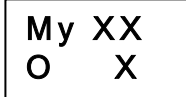

5-1. M y X X X

- The 1st 2nd character 'My' indicates the model name of SAW Filter SFX733EYJ02.
- The 3rd character 'X' indicates the year and the month of manufacture..

Year	Month											
	1	2	3	4	5	6	7	8	9	10	11	12
2017	1	2	3	4	5	6	7	8	9	A	B	C
2018	D	E	F	G	H	I	J	K	L	M	N	O
2019	P	Q	R	S	T	U	V	W	X	Y	Z	a
2020	1	2	3	4	5	6	7	8	9	A	B	C

※ This rotates by the 3 years.

- The 4th, 5th character 'X' indicates Lot No.

5-2. ○

- This symbol indicates input pin 1.
- This indicates the producing center
 - : China

5-3. Marking : Laser Marking

6. PERFORMANCE

6-1. MAXIMUM RATINGS

CHARACTERISTICS	RATINGS	UNITS	NOTES
DC Permissive Voltage	5	V	
Input Power	30	dBm	55 °C, 5000 h
Operating Temperature Range	- 20 ~ +85	°C	
Storage Temperature Range	- 40 ~ +85	°C	

6-2. ELECTRICAL CHARACTERISTICS
6-2-1. TABLE

Ta = -20 ~ +85℃

*1. PCB loss is de-embedded.

Item	CONDITION [MHz]	UNIT	RATING			Note
			Min.	Typ.(25℃)	Max.	
TX → ANTENNA						
Insertion Loss(*1)	718.24 ~ 747.76	dB		1.95	2.8	
Inband Ripple	718.24 ~ 747.76	dB		0.8	1.7	
VSWR	718 ~ 748	-		1.6	2.1	
Absolute Attenuation	10 ~ 698	dB	25	30		
	698 ~ 710	dB	15	33		
	773 ~ 803	dB	45	51		
	1436~1496	dB	32	38		
	1565.42~1605.89	dB	30	36		
	1830~1880	dB	30	34		
	2154~2244	dB	25	32		
	2400~2500	dB	25	31		
	2872~2992	dB	20	27		
	3590~3740	dB	18	23		
	4308~4488	dB	30	39		
5026~5850	dB	20	30			
Termination Impedance : Tx / ANT			50Ω(+ 9.2[nH]) / 50Ω(// 7.8[nH])			
ANTENNA → RX						
Insertion Loss(*1)	773.24 ~ 802.76	dB		2.0	2.5	
Inband Ripple	773.24 ~ 802.76	dB		0.6	1.6	
VSWR	773 ~ 803	-		1.7	2.2	
Absolute Attenuation	1~718	dB	40	55		
	718~748	dB	50	59		
	1710~1785	dB	40	64		
	1850~1920	dB	40	63		
	1920~2400	dB	40	60		
	2400~2500	dB	40	60		
	2484~2775	dB	40	60		
	2775~2880	dB	40	60		
2880~6000	dB	30	46			
Termination Impedance : ANT / Rx			50Ω(// 7.8[nH]) / 50Ω(+ 4.4[nH])			

TX → RX						
Isolation between Rx and Tx	718.24 ~ 747.76	dB	57	61		
	773.24 ~ 802.76	dB	55	58		

6-2-2. TEST FIXTURE

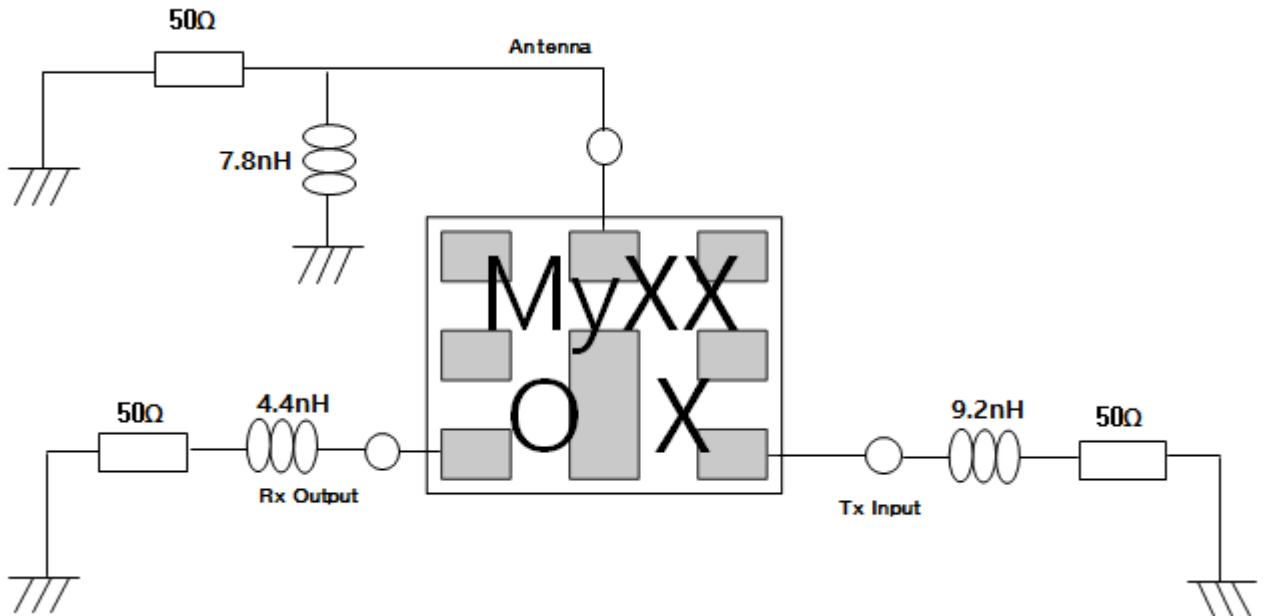

[X-Ray Top View]

6-2-3. GRAPH

Tx→Ant, Ant→Rx Transmission Characteristics

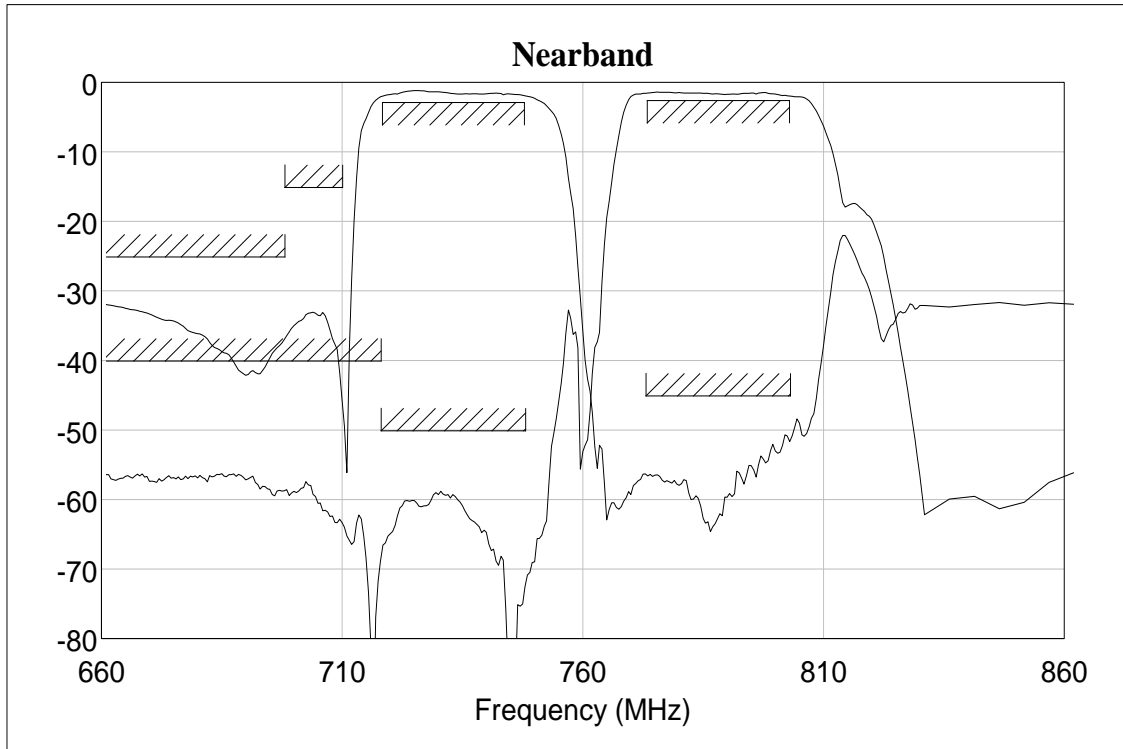

Tx→Rx Isolation Characteristics

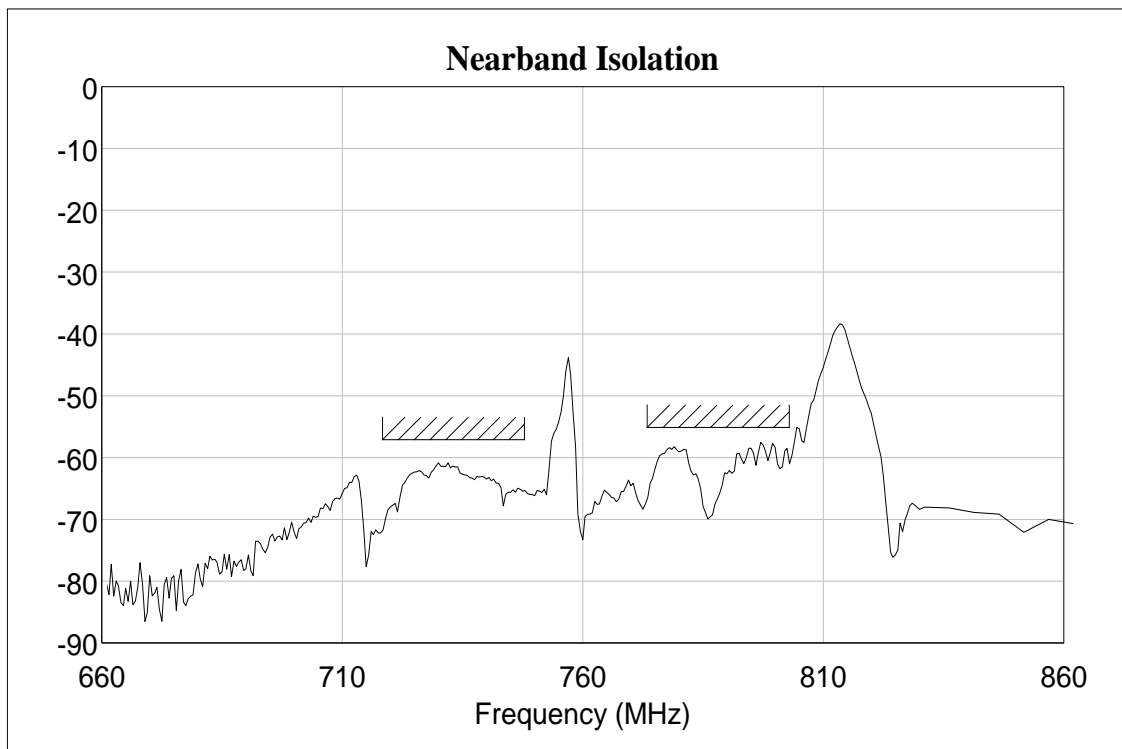

Tx→Ant, Ant→Rx Transmission Characteristics(Wideband)

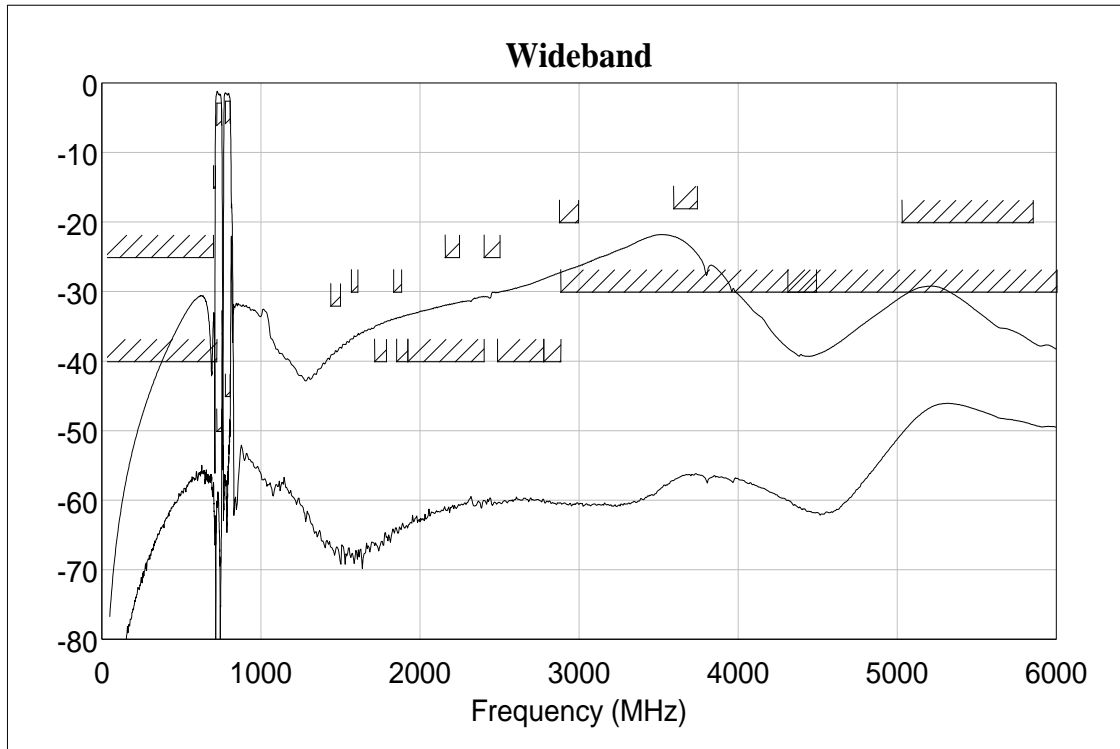

Tx→Rx Isolation Characteristics (Wideband)

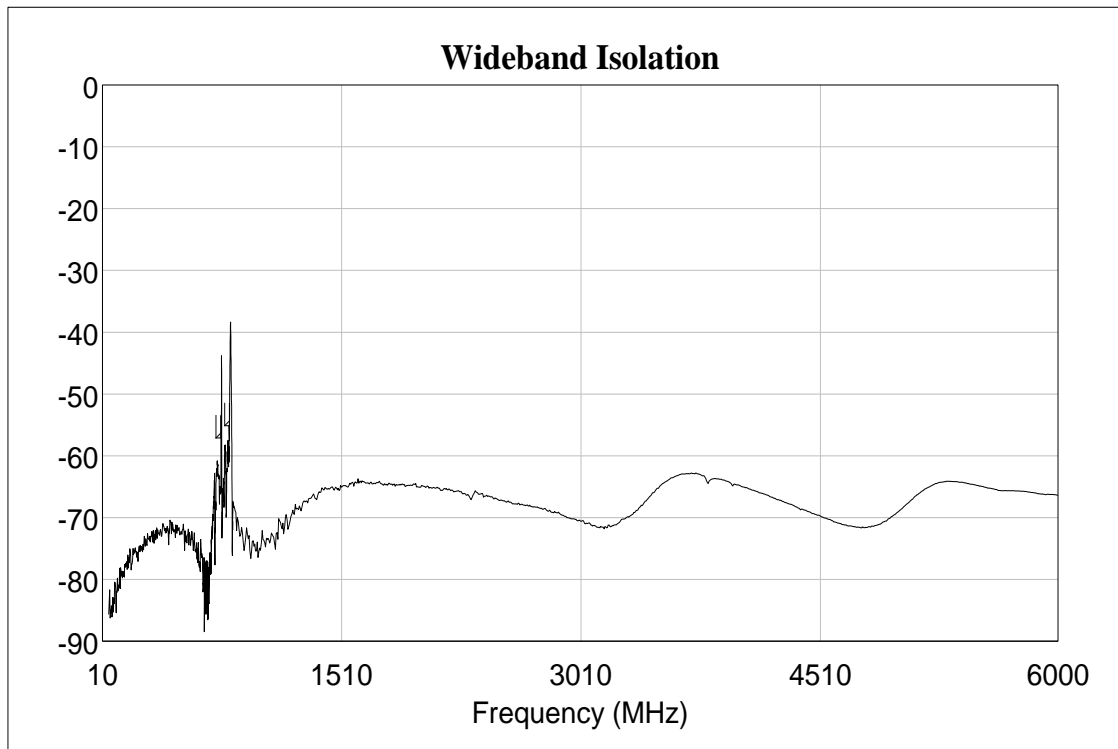

Smithchart

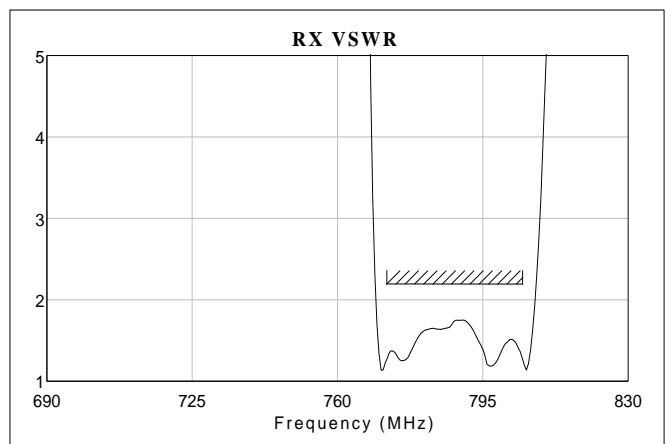
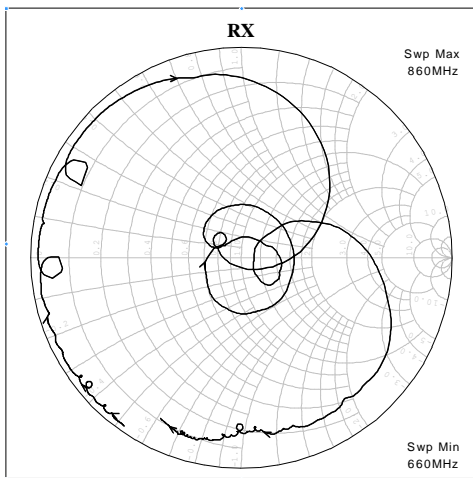
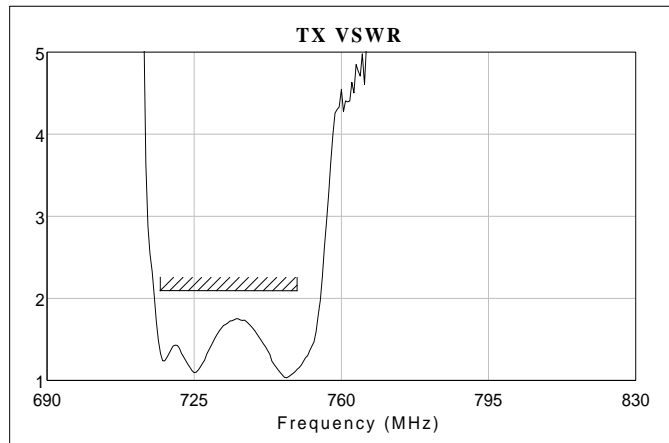
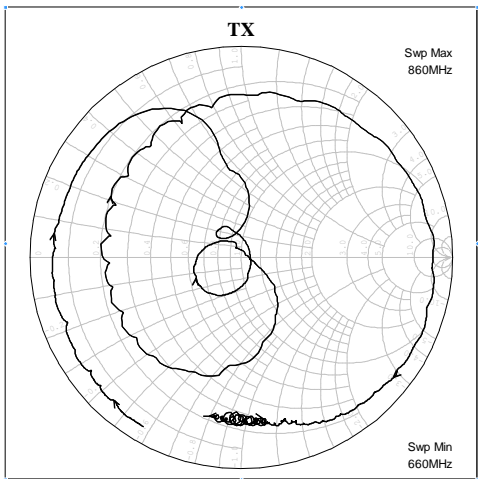
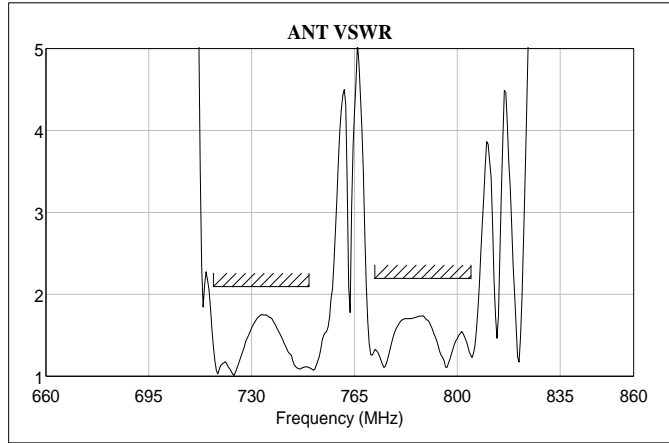
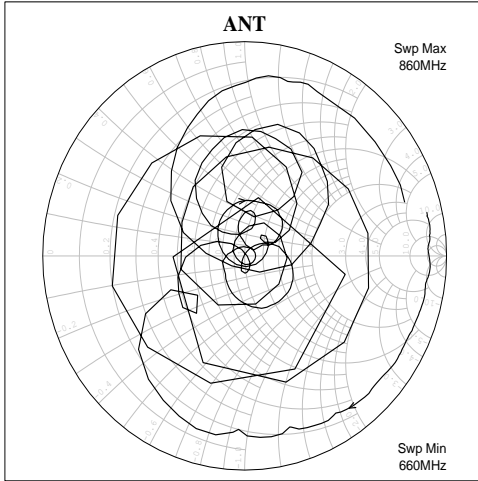

7. RELIABILITY

7-1. ENGINEERING SAMPLE FLOW CHART

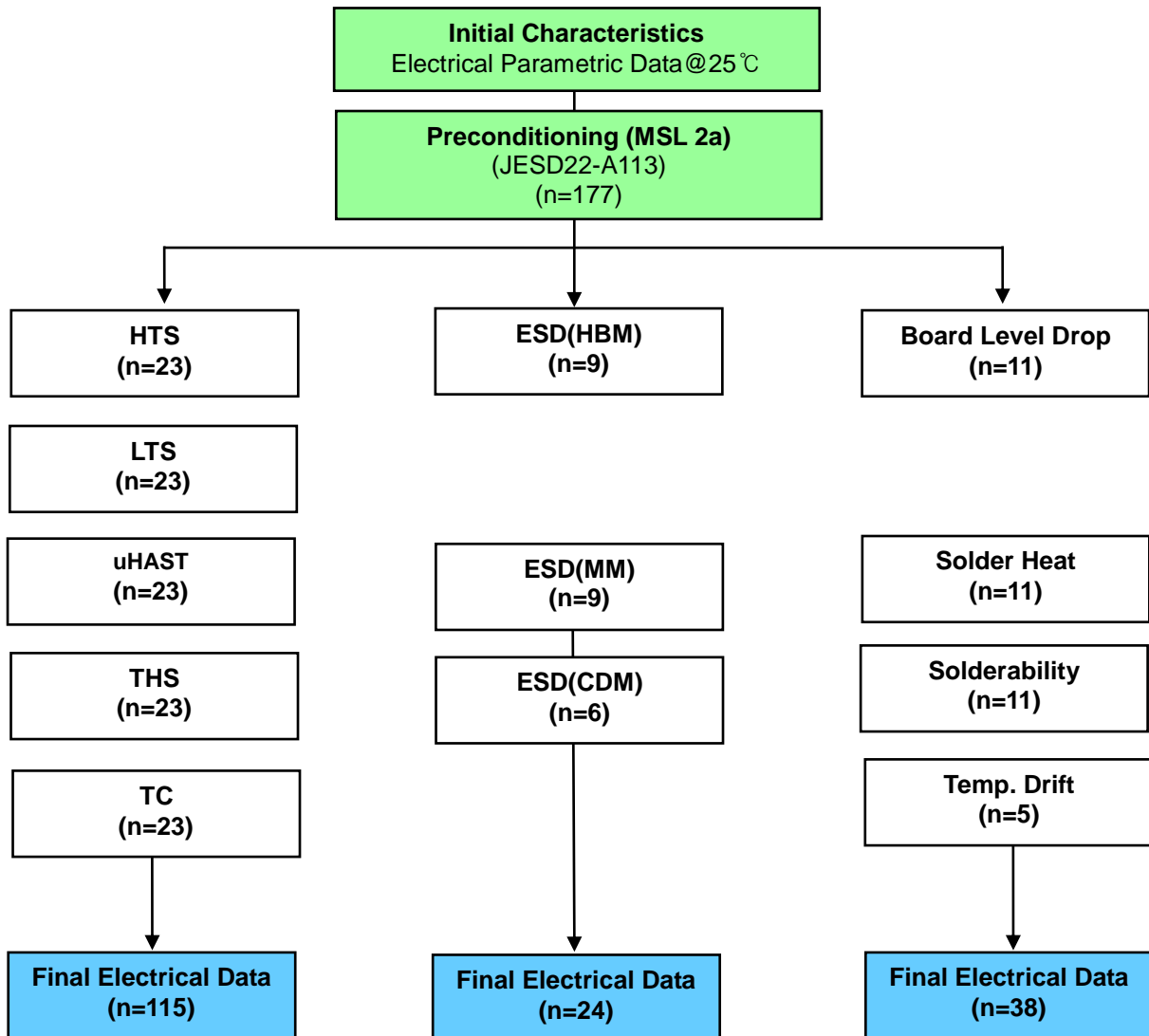

7-2. TEST ITEM & CONDITION

CATEGORY	TEST ITEM	TEST CONDITION	REMARK
	Preconditioning	Bake + Soak(MSL or above) + 3X Reflow duration (Soak 60°C 60% 120HR)	JESD22-A113



TEST ITEM	REMARK	TEST CONDITION	Duration
HTS (High Temperature Storage)	JESD22-A103	condition A +125(-10/+0)°C	1000hr
LTS (Low Temperature Storage)	JESD22-A119	condition A -40(-10/+0)°C	1000hr
uHAST (Unbiased HAST)	JESD22-A118	condition A 130±2°C, 85±5%, 33.3psi	96hr
THS (Temperature Humidity Storage)	JESD22-A101	85±2°C, 85±5% RH	1000hr
TC (Temperature Cycle)	JESD22-A104	condition B (-55°C⇔ +125°C) Soak mode 4 (30min)	500cycle
ESD(HBM)	JESD22-A114	200V, 250V, 300V	All pin 1sec 1time
ESD(MM)	JESD22-A115	100V 150V 200V	All pin 1sec 1time
ESD(CDM)	JESD22-C101	1.0KV, 1.2KV	All pin 1sec 1time
Board Level Drop Test	-	120 cm, 152 cm	12times 19times
Solder Heat Resistance	JESD22-B106C	260°C Solder Pore Dipping	10sec
Solderability	JESD22-B102E	235°C Solder Pore Dipping	3sec
Temp Drift		-40°C => 25°C => 125°C	조건당 2HR

8. REFLOW CONDITION

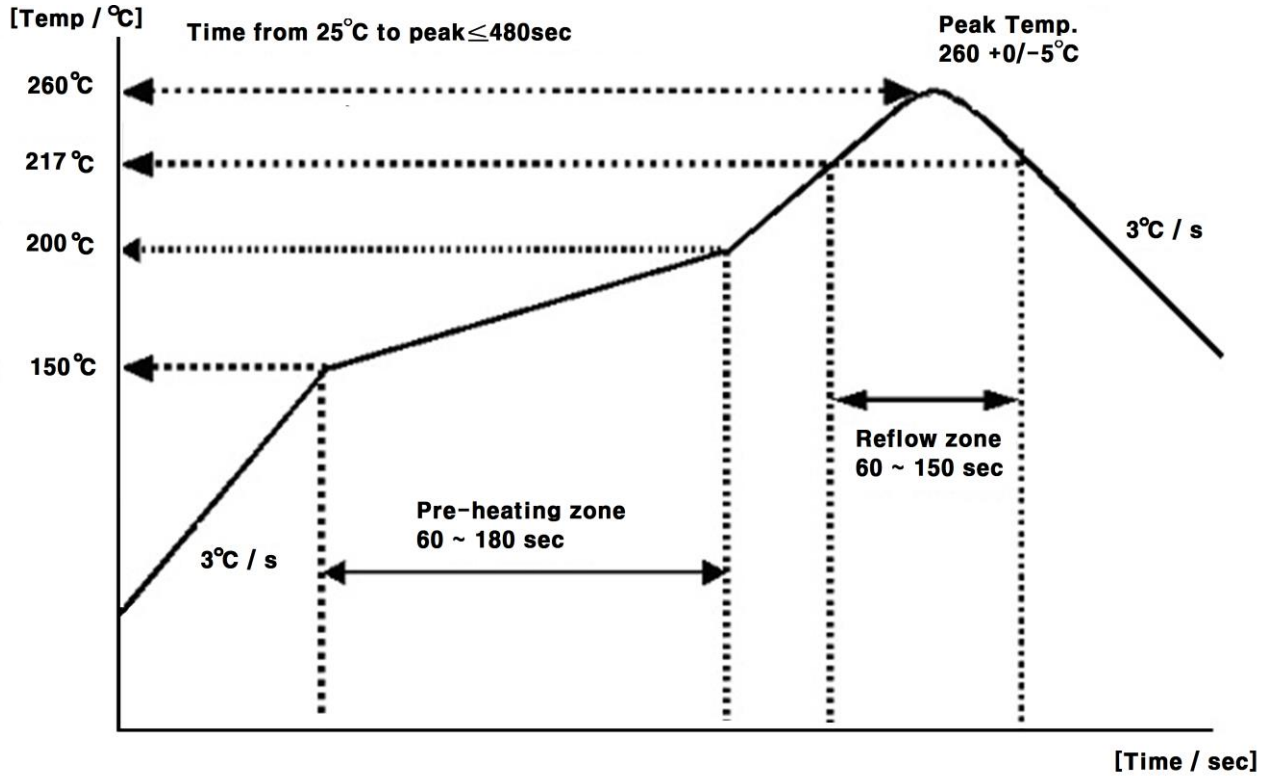

9. RECOMMENDED PCB DIMENSIONS

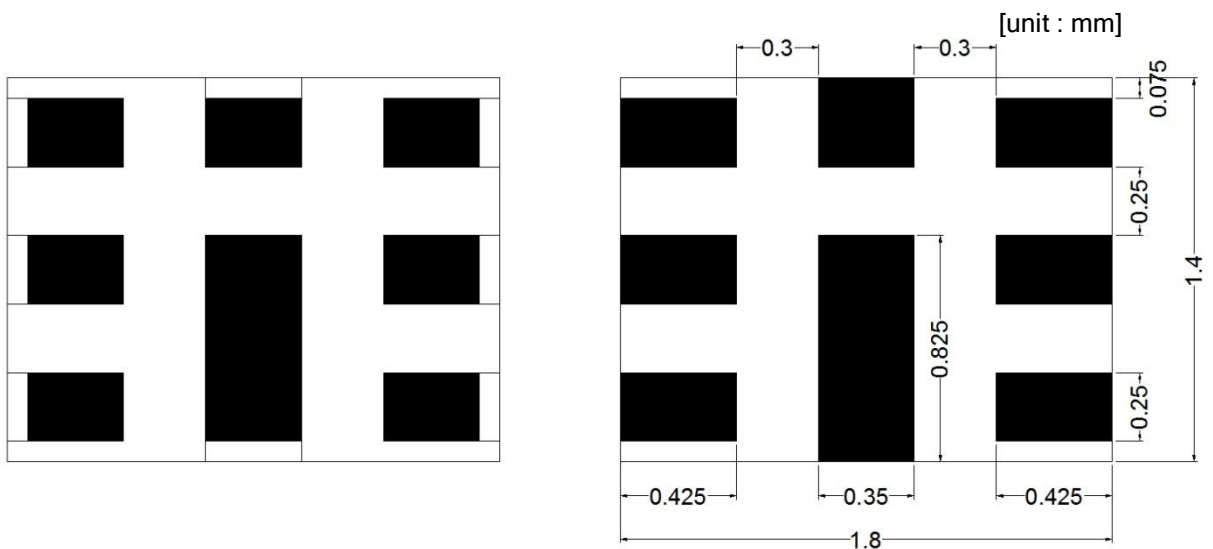

[SAW, X-ray Top view]

[PCB, X-ray Top view]

10. CAUTION

Moisture Sensitivity Device Caution (MSL LEVEL=2a)

1. Calculated shelf life in sealed bag : 12 month at < 40℃ and < 90% relative Humidity(RH)
 2. Peak package body temperature : **260℃**
 3. After bag is opened, devices that will be subjected to reflow solder or other high temperature process must be
 - (a) Mounted within : 672 hours of factory conditions ≤30℃/60% RH, or
 - (b) Stored per J-STD-033
 4. Device require bake, before mounting, if :
 - (a) Humidity Indicator Card reads > 60% when read at 23±5℃
 - (b) 3(a) or 3(b) are not met
 5. If baking is required, refer to IPC/JEDEC J-STD-033 for bake procedure
- Note : Level and body temperature defined by IPC/JEDEC J-STD-020

Aluminum Pack (310mmX370mm)



HIC(Humidity Indication Card)

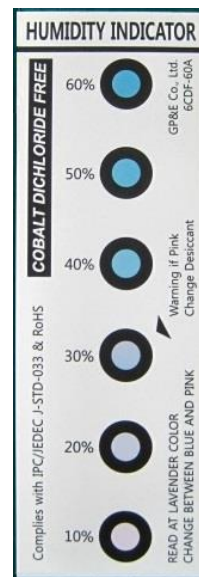

10 to 60% RH

11. PACKING

11-1. DIMENSIONS

- Carrier Tape

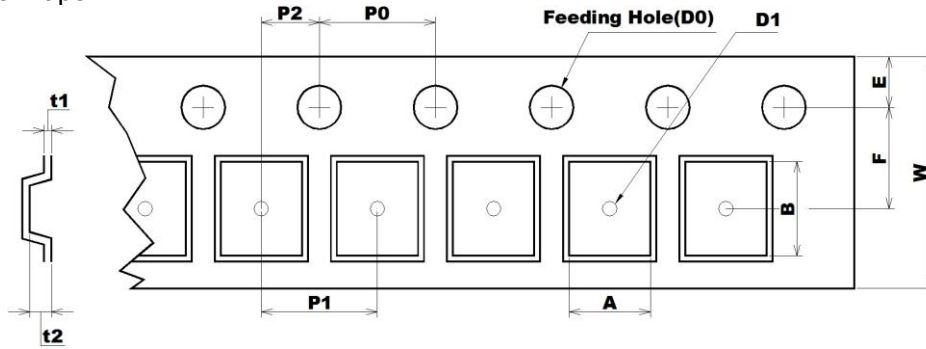

[Unit: mm]

A	B	D0	D1	E	F	P0	P1	P2	t1	t2	W
1.60	2.00	Ø1.55	Ø1.00	1.75	3.50	4.00	4.00	2.00	0.25	0.80	8.00
0.05	0.05	0.05	MIN	0.10	0.05	0.10	0.10	0.05	0.05	0.05	0.10
-0.05	-0.05	-0.05	-	-0.10	-0.05	-0.10	-0.10	-0.05	-0.05	-0.05	-0.10

- Reel

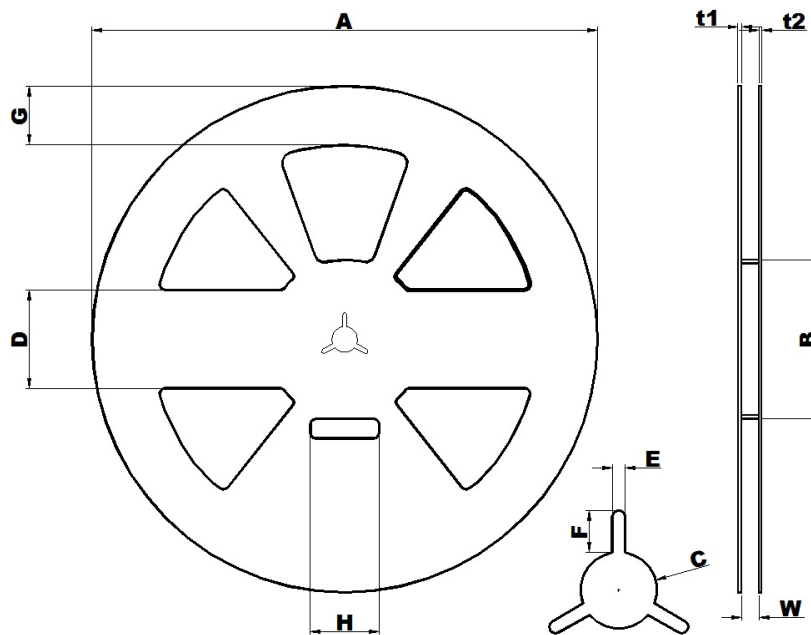

[Unit: mm]

A	B	C	D	E	F	G	H	t1	t2	W
Ø258.0	Ø81.0	Ø13.0	50.0	2.2	7.0	30.0	35.0	1.8	1.5	9.0
+1.0	+1.0	+0.5	+0.8	+0.3	+0.5	+0.8	+1.0	+0.5	+0.5	+1.0
-0.5	-1.0	-0.5	-0.8	-0.3	-0.5	-0.8	-1.0	-0.5	-0.5	-0.5

- The product shall be packed properly not to damaged during transportation and storage.

11-2. REELING QUANTITY

10 inch reel : 8,000 pcs/reel

11-3. TAPING STRUCTURE

11-3-1. The tape shall be wound around the reel in direction shown below.

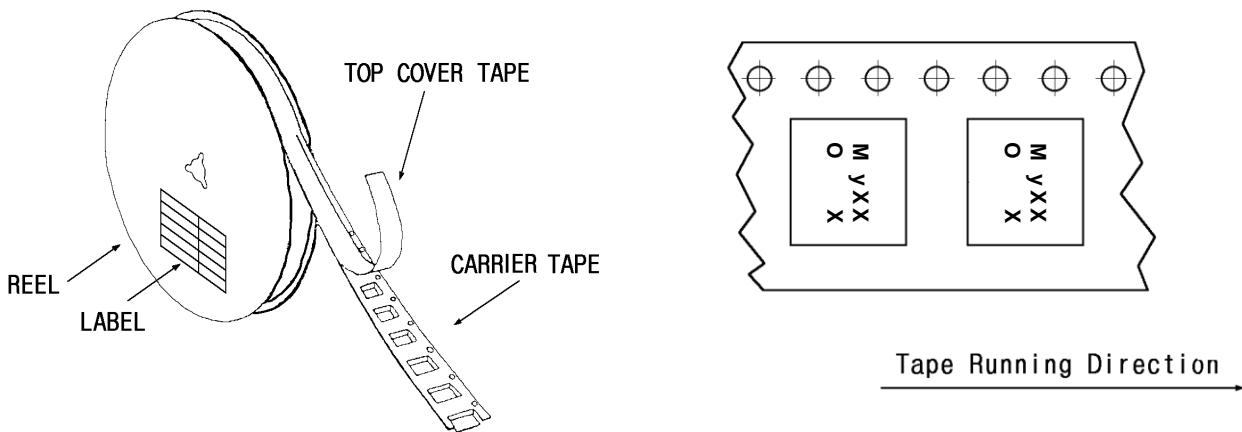

11-3-2. BARCODE LABEL



①	MODEL NAME BARCODE
②	Model Name
③	Reel number
④	Quantity / Marking

1-3-3. Leader part and vacant position specifications.

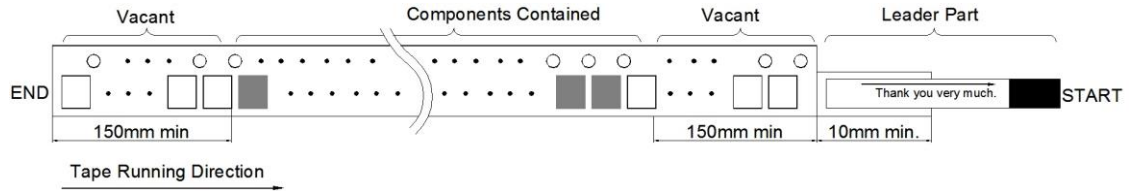

11-4. INNER BOX(Reel Packing) STRUCTURE

Material: Polycarbonate

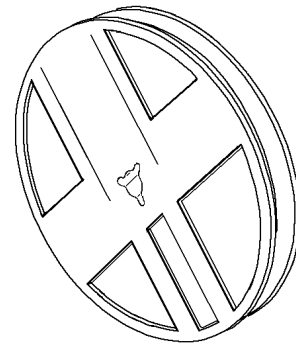

Material : Polyethylene + Aluminium
Size : 310×370mm²

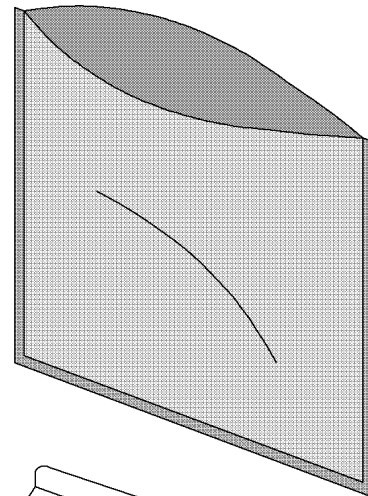

Material : Paper
Size: (D)260×(W)37×(H)265mm³

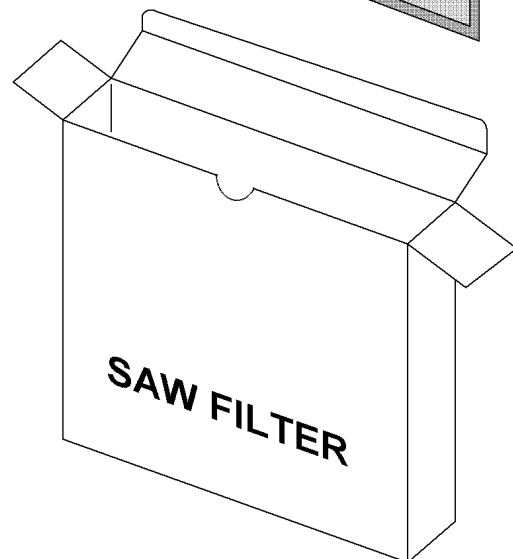

11-5. OUTER BOX STRUCTURE

Material : Paper

TYPE	SIZE(mm)			Inner Box #
	a	b	c	
A	270	240	275	6 boxes

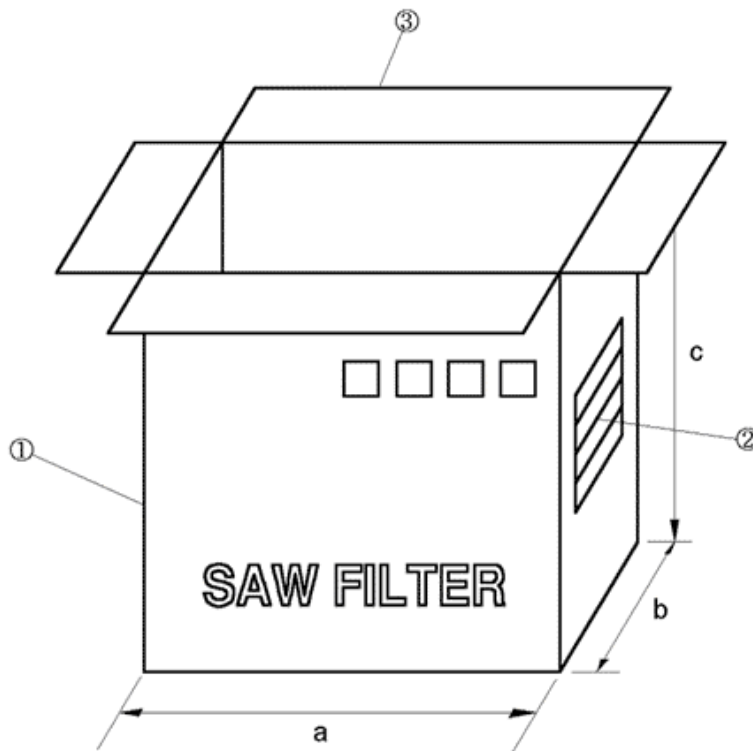

SIDE ①

SIDE ②

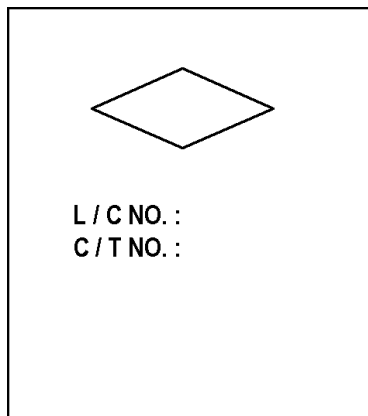

MODEL	
Q'TY	EA
USER	
DATE	. .

- SIDE is the same as front side.

12. TAPE SPECIFICATIONS

12-1. Tensile Strength of Carrier Tape: 4.4N/mm width

12-2. Top Cover Tape Adhesion (See the below figure)

- pull of angle: 0~15 degree
- speed: 300mm/min.
- force: 20~70g

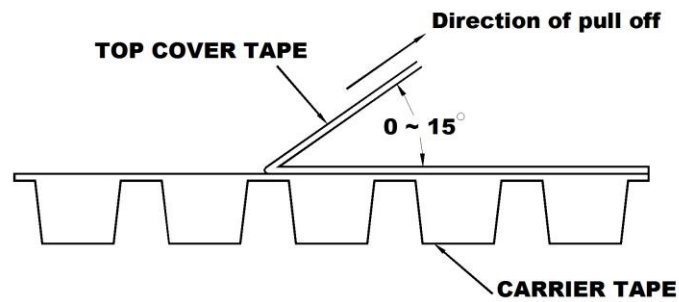

13. RoHS DATA

13-1. RAW MATERIAL(EPOXY)

Test Report

No. TSNEC1700799901

Date: 12 May 2017

Page 1 of 8

TIANJIN WISOL ELECTRONICS CO.,LTD

D1-1/3 INTERNATIONAL INDUSTRIAL CITY XEDA TIANJIN CHINA

The following sample(s) was/were submitted and identified on behalf of the clients as : EPOXY

SGS Job No. : TP17-003447 - TJ
 Date of Sample Received : 08 May 2017
 Testing Period : 08 May 2017 - 12 May 2017
 Test Requested : Selected test(s) as requested by client.
 Test Method : Please refer to next page(s).
 Test Results : Please refer to next page(s).
 Conclusion : Based on the performed tests on submitted sample(s), the results of Lead, Mercury, Cadmium, Hexavalent chromium, Polybrominated biphenyls (PBBs), Polybrominated diphenyl ethers (PBDEs) and Phthalates such as Bis(2-ethylhexyl) phthalate (DEHP) , Butyl benzyl phthalate (BBP), Dibutyl phthalate (DBP) , and Diisobutyl phthalate (DIBP) comply with the limits as set by RoHS Directive (EU) 2015/863 amending Annex II to Directive 2011/65/EU.

Signed for and on behalf of
 SGS-CSTC Standards Technical Services (Tianjin) Co., Ltd.



Reabeca Zhou
 Approved Signatory



Unless otherwise agreed in writing, this document is issued by the Company subject to its General Conditions of Service printed overleaf, available on request or accessible at <http://www.sgs.com/en/Terms-and-Conditions.aspx> and, for electronic format documents, subject to Terms and Conditions for Electronic Documents at <http://www.sgs.com/en/Terms-and-Conditions/Terms-e-Document.aspx>. Attention is drawn to the limitation of liability, indemnification and jurisdiction issues defined therein. Any holder of this document is advised that information contained hereon reflects the Company's findings at the time of its intervention only and within the limits of Client's instructions, if any. The Company's sole responsibility is to its Client and this document does not exonerate parties to a transaction from exercising all their rights and obligations under the transaction documents. This document cannot be reproduced except in full, without prior written approval of the Company. Any unauthorized alteration, forgery or falsification of the content or appearance of this document is unlawful and offenders may be prosecuted to the fullest extent of the law. Unless otherwise stated the results shown in this test report refer only to the sample(s) tested.

Attention: To check the authenticity of testing inspection report & certificate, please contact us at telephone: (86-755) 8307 1443, or email: CN_Doccheck@sgs.com
 SGS Mansion, No.41, The 5th Avenue TEDA, Tianjin, China 300457 t (86-22) 65289000 f (86-22) 25295252 www.sgsgroup.com.cn
 中国·天津市经济技术开发区第五大街41号SGS大厦 邮编: 300457 t (86-22) 65289000 f (86-22) 25295252 e sgs.china@sgs.com

Member of the SGS Group (SGS SA)



Test Report

No. TSNEC1700799901

Date: 12 May 2017

Page 2 of 8

Test Results :

Test Part Description :

Specimen No.	SGS Sample ID	Description
SN1	TSN17-007999.001	black film

Remarks :

- (1) 1 mg/kg = 0.0001%
- (2) MDL = Method Detection Limit
- (3) ND = Not Detected (< MDL)
- (4) "-" = Not Regulated

RoHS Directive (EU) 2015/863 amending Annex II to Directive 2011/65/EU

- Test Method :
- (1) With reference to IEC 62321-5:2013, determination of Cadmium by ICP-OES.
 - (2) With reference to IEC 62321-5:2013, determination of Lead by ICP-OES.
 - (3) With reference to IEC 62321-4:2013, determination of Mercury by ICP-OES.
 - (4) With reference to IEC 62321-7-2:2017, determination of Hexavalent Chromium by Colorimetric Method using UV-Vis and/or with reference to IEC 62321-5:2013, determination of Chromium by ICP-OES.
 - (5) With reference to IEC 62321-6:2015, determination of PBBs and PBDEs by GC-MS.
 - (6) With reference to IEC 62321-8:2017, determination of phthalates by GC-MS.

Test Item(s)	Limit	Unit	MDL	001
Cadmium (Cd)	100	mg/kg	2	ND
Lead (Pb)	1000	mg/kg	2	ND
Mercury (Hg)	1000	mg/kg	2	ND
Hexavalent Chromium (Cr(VI))	1000	mg/kg	8	ND
Sum of PBBs	1000	mg/kg	-	ND
Monobromobiphenyl	-	mg/kg	5	ND
Dibromobiphenyl	-	mg/kg	5	ND
Tribromobiphenyl	-	mg/kg	5	ND
Tetrabromobiphenyl	-	mg/kg	5	ND
Pentabromobiphenyl	-	mg/kg	5	ND
Hexabromobiphenyl	-	mg/kg	5	ND
Heptabromobiphenyl	-	mg/kg	5	ND
Octabromobiphenyl	-	mg/kg	5	ND
Nonabromobiphenyl	-	mg/kg	5	ND
Decabromobiphenyl	-	mg/kg	5	ND



Unless otherwise agreed in writing, this document is issued by the Company subject to its General Conditions of Service printed overleaf, available on request or accessible at <http://www.sgs.com/en/Terms-and-Conditions.aspx> and, for electronic format documents, subject to Terms and Conditions for Electronic Documents at <http://www.sgs.com/en/Terms-and-Conditions/Terms-e-Documents.aspx>. Attention is drawn to the limitation of liability, indemnification and jurisdiction issues defined therein. Any holder of this document is advised that information contained hereon reflects the Company's findings at the time of its intervention only and within the limits of Client's instructions, if any. The Company's sole responsibility is to its Client and this document does not exonerate parties to a transaction from exercising all their rights and obligations under the transaction documents. This document cannot be reproduced except in full, without prior written approval of the Company. Any unauthorized alteration, forgery or falsification of the content or appearance of this document is unlawful and offenders may be prosecuted to the fullest extent of the law. Unless otherwise stated the results shown in this test report refer only to the sample(s) tested.

Attention: To check the authenticity of testing/inspection report & certificate, please contact us at telephone: (86-755) 8387 1443, or email: CN.Qcc@sgs.com
 SGS Mansion, No.41, The 5th Avenue TEDA, Tianjin, China 300457 t (86-22) 65288000 f (86-22) 25296252 www.sgs.com.cn
 中国·天津市经济技术开发区第五大街41号SGS大厦 邮编: 300457 t (86-22) 65288000 f (86-22) 25296252 e sgs.china@sgs.com

Member of the SGS Group (SGS SA)

Test Report

No. TSNEC1700799901

Date: 12 May 2017

Page 3 of 8

<u>Test Item(s)</u>	<u>Limit</u>	<u>Unit</u>	<u>MDL</u>	<u>001</u>
Sum of PBDEs	1000	mg/kg	-	ND
Monobromodiphenyl ether	-	mg/kg	5	ND
Dibromodiphenyl ether	-	mg/kg	5	ND
Tribromodiphenyl ether	-	mg/kg	5	ND
Tetrabromodiphenyl ether	-	mg/kg	5	ND
Pentabromodiphenyl ether	-	mg/kg	5	ND
Hexabromodiphenyl ether	-	mg/kg	5	ND
Heptabromodiphenyl ether	-	mg/kg	5	ND
Octabromodiphenyl ether	-	mg/kg	5	ND
Nonabromodiphenyl ether	-	mg/kg	5	ND
Decabromodiphenyl ether	-	mg/kg	5	ND
Dibutyl phthalate (DBP)	1000	mg/kg	50	ND
Butyl benzyl phthalate (BBP)	1000	mg/kg	50	ND
Bis (2-ethylhexyl) phthalate (DEHP)	1000	mg/kg	50	ND
Diisobutyl Phthalates (DIBP)	1000	mg/kg	50	ND

Notes :

- (1) The maximum permissible limit is quoted from RoHS Directive (EU) 2015/863. IEC 62321 series is equivalent to EN 62321 series
http://www.cenelec.eu/dyn/www/f?p=104:30:1742232870351101:::FSP_ORG_ID,FSP_LANG_ID:1258637,25
- (2) The result of Hexavalent Chromium (Cr(VI)) is "ND" as the result of Chromium (Cr) is "ND", and confirmation test of Hexavalent Chromium (Cr(VI)) is not required .
- (3) If the Chromium (Cr) content is greater than the MDL of Hexavalent Chromium (Cr(VI)), confirmation test of Hexavalent Chromium (Cr(VI)) is required.
- (4) On 4 June 2015, Commission Directive (EU) 2015/863 was published in the Official Journal of the European Union (OJEU) to include the phthalates BBP, DBP, DEHP and DIBP into ANNEX II of the Rohs Recast Directive. The new law restricts each phthalate to no more than 0.1% in each homogeneous material of an electrical product.
- (5) The restriction of DEHP, BBP, DBP and DIBP shall apply to medical devices, including in vitro medical devices, and monitoring and control instruments, including industrial monitoring and control instruments, from 22 July 2021.
- (6) The restriction of DEHP, BBP, DBP and DIBP shall not apply to cables or spare parts for the repair, the reuse, the updating of functionalities or upgrading of capacity of EEE placed on the market before 22 July 2019, and of medical devices, including in vitro medical devices, and monitoring and control instruments, including industrial monitoring and control instruments, placed on the market before 22 July 2021.
- (7) The restriction of DEHP, BBP and DBP shall not apply to toys which are already subject to the restriction of DEHP, BBP and DBP through entry 51 of Annex XVII to Regulation (EC) No 1907/2006.

Halogen

Unless otherwise agreed in writing, this document is issued by the Company subject to its General Conditions of Service printed overleaf, available on request or accessible at <http://www.sgs.com/en/Terms-and-Conditions.aspx> and, for electronic format documents, subject to Terms and Conditions for Electronic Documents at <http://www.sgs.com/en/Terms-and-Conditions/Terms-e-Documents.aspx>. Attention is drawn to the limitation of liability, indemnification and jurisdiction issues defined therein. Any holder of this document is advised that information contained hereon reflects the Company's findings at the time of its intervention only and within the limits of Client's instructions, if any. The Company's sole responsibility is to its Client and this document does not exonerate parties to a transaction from exercising all their rights and obligations under the transaction documents. This document cannot be reproduced except in full, without prior written approval of the Company. Any unauthorized alteration, forgery or falsification of the content or appearance of this document is unlawful and offenders may be prosecuted to the fullest extent of the law. Unless otherwise stated the results shown in this test report refer only to the sample(s) tested.

Attention: To check the authenticity of testing/inspection report & certificate, please contact us at telephone: (86-755) 8387 1443, or email: CN.Doccheck@sgs.com

SGS-CSTC Inspection & Testing Services (China) Co., Ltd.
 Chemical Laboratory

SGS Mansion, No.41, The 5th Avenue TEDA, Tianjin, China 300457 t (86-22) 65288000 f (86-22) 2526252 www.sgs.com.cn
 中国·天津市经济技术开发区第五大道41号SGS大厦 邮编: 300457 t (86-22) 65288000 f (86-22) 2526252 e sgs.china@sgs.com

Member of the SGS Group (SGS SA)



Test Report

No. TSNEC1700799901

Date: 12 May 2017

Page 4 of 8

Test Method : With reference to EN 14582: 2016, analysis was performed by Ion Chromatograph (IC).

Test Item(s)	Unit	MDL	001
Chlorine (Cl)	mg/kg	50	99
Bromine (Br)	mg/kg	50	ND

Element(s)

Test Method : With reference to US EPA Method 3052:1996, analysis was performed by ICP-OES.

Test Item(s)	Unit	MDL	001
Antimony (Sb)	mg/kg	10	ND
Tin (Sn)	mg/kg	5	ND



Unless otherwise agreed in writing, this document is issued by the Company subject to its General Conditions of Service printed overleaf, available on request or accessible at <http://www.sgs.com/en/Terms-and-Conditions.aspx> and, for electronic format documents, subject to Terms and Conditions for Electronic Documents at <http://www.sgs.com/en/Terms-and-Conditions/Terms-e-Document.aspx>. Attention is drawn to the limitation of liability, indemnification and jurisdiction issues defined therein. Any holder of this document is advised that information contained hereon reflects the Company's findings at the time of its intervention only and within the limits of Client's instructions, if any. The Company's sole responsibility is to its Client and this document does not exonerate parties to a transaction from exercising all their rights and obligations under the transaction documents. This document cannot be reproduced except in full, without prior written approval of the Company. Any unauthorized alteration, forgery or falsification of the content or appearance of this document is unlawful and offenders may be prosecuted to the fullest extent of the law. Unless otherwise stated the results shown in this test report refer only to the sample(s) tested.

Attention: To check the authenticity of testing inspection report & certificate, please contact us at telephone: (86-755) 8387 1443, or email: CN.Doccheck@sgs.com

SGS Mansion, No.41, The 5th Avenue TEDA, Tianjin, China 300457 t (86-22) 65288000 f (86-22) 25295252 www.sgs.com.cn
 中国·天津市经济技术开发区第五大街41号SGS大厦 邮编: 300457 t (86-22) 65288000 f (86-22) 25295252 e sgs.china@sgs.com

Member of the SGS Group (SGS SA)



Test Report

No. TSNEC1700799901

Date: 12 May 2017

Page 5 of 8

ATTACHMENTS

Pb/Cd/Hg/Cr⁶⁺/PBBs/PBDEs/Phthalates Testing Flow Chart

- 1) Name of the person who made testing: Cathy Zhang/Zhanwen Liu/Ann Wang/Cyhan Chen
- 2) Name of the person in charge of testing: Aaron Wang/Rex Zhu
- 3) These samples were dissolved totally by pre-conditioning method according to below flow chart. (Cr⁶⁺ and PBBs/PBDEs /Phthalates test method excluded)

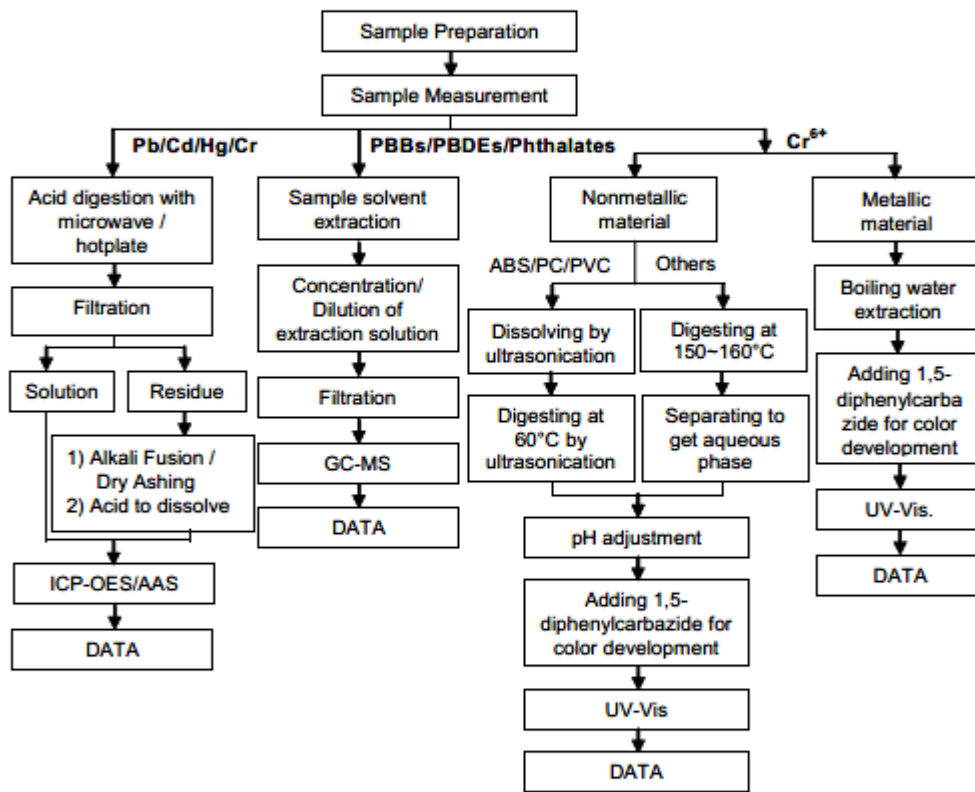

Unless otherwise agreed in writing, this document is issued by the Company subject to its General Conditions of Service printed overleaf, available on request or accessible at <http://www.sgs.com/na/Terms-and-Conditions.aspx> and, for electronic format documents, subject to Terms and Conditions for Electronic Documents at <http://www.sgs.com/na/Terms-and-Conditions/Terms-and-Conditions.aspx>. Attention is drawn to the limitation of liability, indemnification and jurisdiction issues defined therein. Any holder of this document is advised that information contained hereon reflects the Company's findings at the time of its intervention only and within the limits of Client's instructions, if any. The Company's sole responsibility is to its Client and this document does not exonerate parties to a transaction from exercising all their rights and obligations under the transaction documents. This document cannot be reproduced except in full, without prior written approval of the Company. Any unauthorized alteration, forgery or falsification of the content or appearance of this document is unlawful and offenders may be prosecuted to the fullest extent of the law. Unless otherwise stated the results shown in this test report refer only to the sample(s) tested.

Attention: To check the authenticity of testing / inspection report & certificate, please contact us at telephone: (86-755) 8367 1443, or email: CN.Doccheck@sgs.com

SGS Mansion, No.41, The 5th Avenue TEDA, Tianjin, China 300457 t (86-22) 65288000 f (86-22) 2526252 www.sgs.com.cn
中国·天津市经济技术开发区第五大街41号SGS大厦 邮编: 300457 t (86-22) 65288000 f (86-22) 2526252 e sgs.china@sgs.com

Member of the SGS Group (SGS SA)



Test Report

No. TSNEC1700799901

Date: 12 May 2017

Page 6 of 8

ATTACHMENTS

Halogen Testing Flow Chart

- 1) Name of the person who made testing: Jin Wang
- 2) Name of the person in charge of testing: Rex Zhu

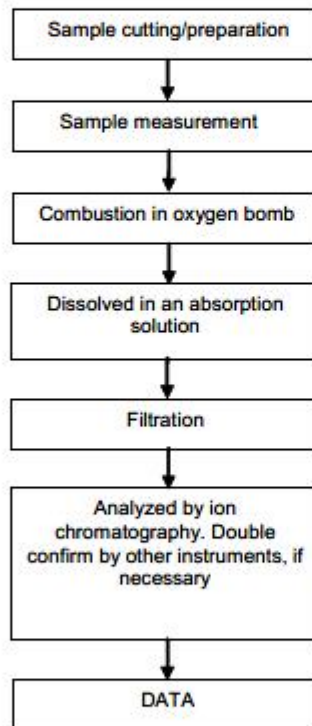

Unless otherwise agreed in writing, this document is issued by the Company subject to its General Conditions of Service printed overleaf, available on request or accessible at <http://www.sgs.com/en/Terms-and-Conditions.aspx> and, for electronic format documents, subject to Terms and Conditions for Electronic Documents at <http://www.sgs.com/en/Terms-and-Conditions/Terms-e-Documents.aspx>. Attention is drawn to the limitation of liability, indemnification and jurisdiction issues defined therein. Any holder of this document is advised that information contained hereon reflects the Company's findings at the time of its intervention only and within the limits of Client's instructions, if any. The Company's sole responsibility is to its Client and this document does not exonerate parties to a transaction from exercising all their rights and obligations under the transaction documents. This document cannot be reproduced except in full, without prior written approval of the Company. Any unauthorized alteration, forgery or falsification of the content or appearance of this document is unlawful and offenders may be prosecuted to the fullest extent of the law. Unless otherwise stated the results shown in this test report refer only to the sample(s) tested.

Attention: To check the authenticity of testing inspection report & certificate, please contact us at telephone: (86-755)83871443, or email: CN_Doccheck@sgs.com

SGS Mansion, No.41, The 5th Avenue TEDA, Tianjin, China 300457 t (86-22) 65288000 f (86-22) 25295252 www.sgs.com.cn
 中国·天津市经济技术开发区第五大道41号SGS大厦 邮编: 300457 t (86-22) 65288000 f (86-22) 25295252 e sgs.china@sgs.com

Member of the SGS Group (SGS SA)



Test Report

No. TSNEC1700799901

Date: 12 May 2017

Page 7 of 8

ATTACHMENTS

Elementary Testing Flow Chart

- 1) Name of the person who made testing: Cathy Zhang
- 2) Name of the person in charge of testing: Aaron Wang

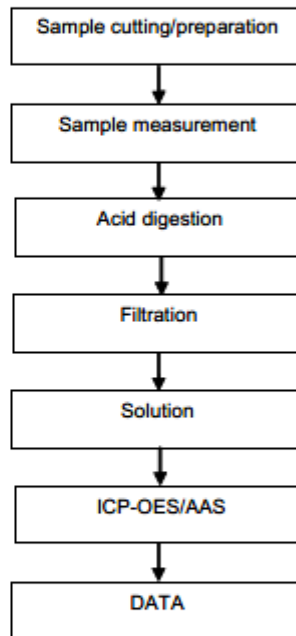

Unless otherwise agreed in writing, this document is issued by the Company subject to its General Conditions of Service printed overleaf, available on request or accessible at <http://www.sgs.com/en/Terms-and-Conditions.aspx> and, for electronic format documents, subject to Terms and Conditions for Electronic Documents at <http://www.sgs.com/en/Terms-and-Conditions/Terms-e-Document.aspx>. Attention is drawn to the limitation of liability, indemnification and jurisdiction issues defined therein. Any holder of this document is advised that information contained hereon reflects the Company's findings at the time of its intervention only and within the limits of Client's instructions, if any. The Company's sole responsibility is to its Client and this document does not exonerate parties to a transaction from exercising all their rights and obligations under the transaction documents. This document cannot be reproduced except in full, without prior written approval of the Company. Any unauthorized alteration, forgery or falsification of the content or appearance of this document is unlawful and offenders may be prosecuted to the fullest extent of the law. Unless otherwise stated the results shown in this test report refer only to the sample(s) tested.

Attention: To check the authenticity of testing/inspection report & certificate, please contact us at telephone: (86-755) 8387 1443, or email: CN_Desccheck@sgs.com

SGS-CSTC Testing Services Co., Ltd.
Chemical Laboratory

SGS Manson, No.41, The 5th Avenue TEDA, Tianjin, China 300457 t (86-22) 65288000 f (86-22) 2626252 www.sgs.com.cn
中国·天津市经济技术开发区第五大街41号SGS大厦 邮编: 300457 t (86-22) 65288000 f (86-22) 2626252 e sgs.china@sgs.com

Member of the SGS Group (SGS SA)



Test Report

No. TSNEC1700799901

Date: 12 May 2017

Page 8 of 8

Sample photo:

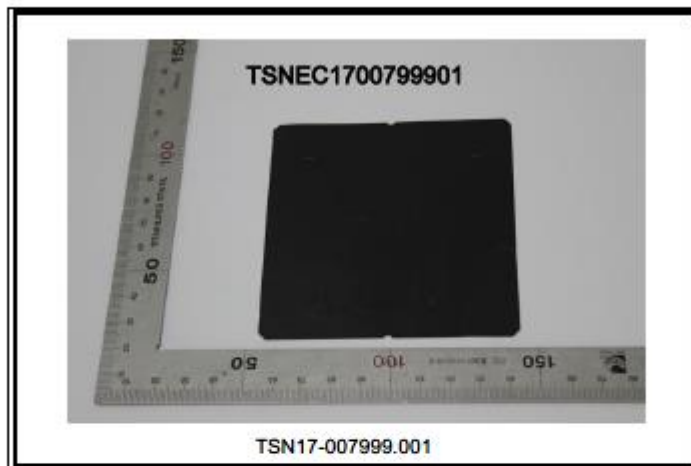

SGS authenticate the photo on original report only

*** End of Report ***



Unless otherwise agreed in writing, this document is issued by the Company subject to its General Conditions of Service printed overleaf, available on request or accessible at <http://www.sgs.com/en/Terms-and-Conditions.aspx> and, for electronic format documents, subject to Terms and Conditions for Electronic Documents at <http://www.sgs.com/en/Terms-and-Conditions/Terms-a-Document.aspx>. Attention is drawn to the limitation of liability, indemnification and jurisdiction issues defined therein. Any holder of this document is advised that information contained hereon reflects the Company's findings at the time of its intervention only and within the limits of Client's instructions, if any. The Company's sole responsibility is to its Client and this document does not exonerate parties to a transaction from exercising all their rights and obligations under the transaction documents. This document cannot be reproduced except in full, without prior written approval of the Company. Any unauthorized alteration, forgery or falsification of the content or appearance of this document is unlawful and offenders may be prosecuted to the fullest extent of the law. Unless otherwise stated the results shown in this test report refer only to the sample(s) tested.

Attention: To check the authenticity of testing/inspection report & certificate, please contact us at telephone: (86-755) 8387 1443, or email: CN_Scccheck@sgs.com

SGS Mansion, No.41, The 5th Avenue TEDA, Tianjin, China 300457 | (86-22) 65289000 | (86-22) 25295252 | www.sgs.com.cn
 中国·天津市经济技术开发区第五大街41号SGS大厦 | 邮编: 300457 | (86-22) 65289000 | (86-22) 25295252 | sgs.china@sgs.com

Member of the SGS Group (SGS SA)

13-2. RAW MATERIAL(PACKAGE)



TEST REPORT

REPORT NO. JP/2017/111101

DATE: January 12, 2018

PAGE: 1 OF 4

KYOCERA CORPORATION

1810 TAKI-CHO SATSUMASENDAI-SHI KAGOSHIMA JAPAN

THE FOLLOWING SAMPLE(S) WAS/WERE SUBMITTED AND IDENTIFIED BY/ON BEHALF OF THE CLIENT AS:

以下のサンプルは顧客により提供され、顧客に代わって確認を行いました:

SAMPLE DESCRIPTION : 1-01-4-18 KYOCERA-CERAMIC A440

CLIENT REF.NO :

SAMPLE RECEIVED : 2017/11/24

TESTING DATE : 2017/11/24 TO 2018/01/12

TEST REQUESTED : SELECTED TEST(S) AS REQUESTED BY CLIENT.
分析項目 : 分析項目は顧客の要求によります。

TEST METHOD(S) : WITH REFERENCE TO LATEST EDITION OF IEC62321 FOR RoHS 6 SUBSTANCES.
分析手法 : OTHER CHEMICALS WERE TESTED BY EACH APPROPRIATE METHOD.
RoHS6物質の分析は最新版のIEC62321を参照しました。
それ以外の化学物質についてはそれぞれに最適な方法で分析を行いました。

TEST RESULT(S) : PLEASE REFER TO THE NEXT PAGE(S).
分析結果 : 以下のページをご参照願います。

大内 幸弘



Yukihiro Ouchi / Quality Manager
SGS Japan Inc., Chemical Laboratory

This Test Report is issued by the Company under its General Conditions of Service printed overseas or available on request and accessible at <http://www.sgs.com>. Attention is drawn to the limitation of liability, indemnification and jurisdiction issues defined therein. Unless otherwise stated the results shown in this Test Report refer only to the sample(s) tested. This Test Report cannot be reproduced except, in full, without prior approval of the Company. Any unauthorized alteration, forgery or falsification of the content or appearance of this test report is unlawful and offenders may be prosecuted to the fullest extent of the law.

この検査報告書は表紙に記載された、もしくは<http://www.sgs.com>で入手が可能なサービスに関する一般的条件に準じて発行されます。さらさらに規定されている弊社の負うべき義務・補償の範囲及び司法管轄の項目をご確認ください。他に特に明記のない限り、この検査報告書に記載された結果は、検査した試料のみに着します。この書面全体の複製以外には、弊社からの事前の許可を得ること無く複製することを禁じます。この検査報告書を無断で変更、偽造、改ざんすることは違法であり、違反者に対しては法的手段を講ずることとなります。

SGS Japan Inc. | YBP East Tower 12F, 134 Godo-cho Hodogaya-ku Yokohama 240-0005, Japan
t +81(0) 45 330 1100 f +81(0) 45 330 1108 URL: www.jp.sgs.com

Member of the SGS Group (Société Générale de Surveillance)



TEST REPORT

REPORT NO. JP/2017/111101

DATE: January 12, 2018

PAGE: 2 OF 4

KYOCERA CORPORATION

1810 TAKI-CHO SATSUMASENDAI-SHI KAGOSHIMA JAPAN

TEST RESULT(S)

ITEM(S)	UNIT	RESULT	METHOD	INST./PLACE	MDL
CADMIUM(Cd)	mg/kg	N.D.	IEC62321-5: 2013	ICP-OES	2
LEAD(Pb)	mg/kg	N.D.	IEC62321-5: 2013	ICP-OES	2
MERCURY(Hg)	mg/kg	N.D.	IEC62321-4: 2013	ICP-OES	2
CHROMIUM VI(Cr(VI))	mg/kg	N.D.	IEC 62321-7-1: 2015	UV/VIS	2

NOTES: mg/kg = ppm, N.D. = Not Detected, INST. = INSTRUMENT, MDL = Method Detection Limit

REMARK: Test process and/or expression of test result have been specified by client.

The content of Cr(VI) has been calculated with regard to the sample weight as specified by client.

This Test Report is issued by the Company under its General Conditions of Service printed overleaf or available on request and accessible at <http://www.sgs.com>. Attention is drawn to the limitation of liability, indemnification and jurisdiction issues defined therein. Unless otherwise stated the results shown in this Test Report refer only to the sample(s) tested. This Test Report cannot be reproduced except, in full, without prior approval of the Company. Any unauthorized alteration, forgery or falsification of the content or appearance of this test report is unlawful and offenders may be prosecuted to the fullest extent of the law. JP
 この検査報告書は裏面に記載された、もしくは <http://www.sgs.com> で入手可能なサービスに関する一般約条件に準じて発行されます。それらに記載されている弊社の負うべき義務・補償の範囲及び司法管轄の項目をご確認ください。他に特に明記のない限り、この検査報告書に記載された結果は、検査した試料のみに着します。この書面全体の複製以外には、弊社からの事前の許可を得ること無く複製することを禁じます。この検査報告書を無断で変更、偽造、改ざんすることは違法であり、違反者に対しては法的手段を通じることをとります。

SGS Japan Inc. | YBP East Tower 12F, 134 Godo-cho Hodogaya-ku Yokohama 240-0005, Japan
 t +81(0) 45 330 1100 f +81(0) 45 330 1108 URL: www.jp.sgs.com

Member of the SGS Group (Société Générale de Surveillance)



TEST REPORT

REPORT NO. JP/2017/111101

DATE: January 12, 2018

PAGE: 3 OF 4

KYOCERA CORPORATION

1810 TAKI-CHO SATSUMASENDAI-SHI KAGOSHIMA JAPAN

分析フローチャート MEASUREMENT FLOW CHART

1)酸分解前処理において試料を完全分解しています。

The sample was dissolved/ decomposed totally by acid pre-conditioning method according to below flow chart.

2)Cd, Pb, Hg, Cr, Cr(VI), PBB/PBDE

分析担当者 Name of the person in charge of measurement: 及川 聡子 Satoko Oikawa

3)分析責任者 Name of the person responsible for measurement: 大谷 真由美 Mayumi Otani

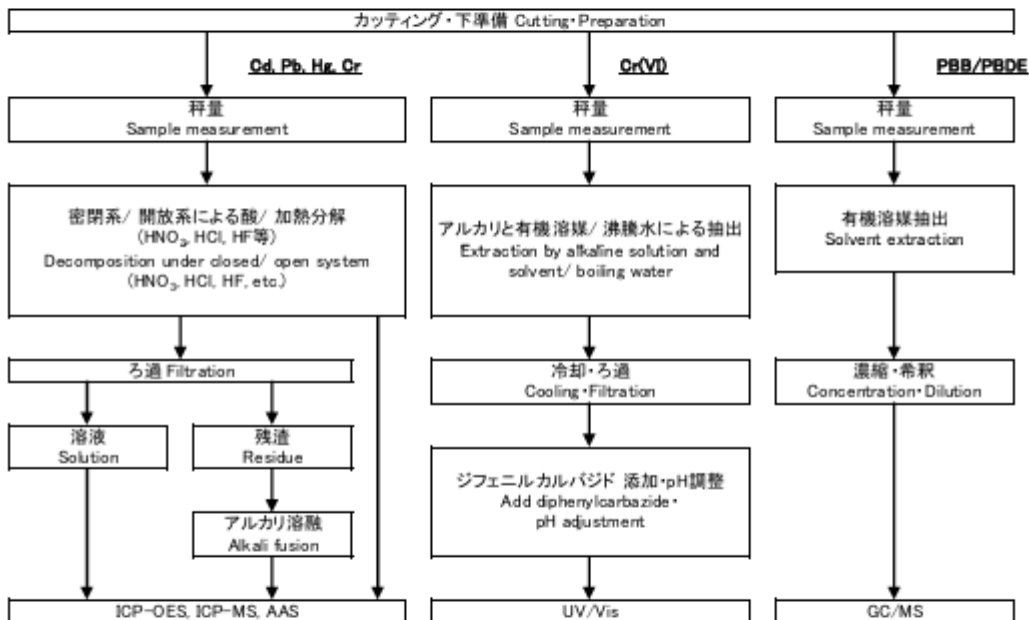

This Test Report is issued by the Company under its General Conditions of Service printed overleaf or available on request and accessible at <http://www.sgs.com>. Attention is drawn to the limitation of liability, indemnification and jurisdiction issues defined therein. Unless otherwise stated the results shown in this Test Report refer only to the sample(s) tested.

This Test Report cannot be reproduced, in full, without prior approval of the Company. Any unauthorized alteration, forgery or falsification of the content or appearance of this test report is unlawful and offenders may be prosecuted to the fullest extent of the law.

この検査報告書は裏面に記載された、もしくは<http://www.sgs.com>で入手可能なサービスに関する一般的条件に引いて発行されます。それらに明記されている弊社の負うべき債務・義務の範囲及び司法管轄の項目をご確認ください。他に特に明記のない限り、この検査報告書に記載された結果は、検査した試料のみに着します。この書面全体の複製以外には、弊社からの事前の許可を得ること無く複製することを禁じます。この検査報告書を無断で変更、偽造、改ざんすることは違法であり、違反者に対しては法的な手段を講ずることとなります。

SGS Japan Inc. YBP East Tower 12F, 134 Godo-cho Hodogaya-ku Yokohama 240-0005, Japan
t +81101 45 330 1100 f +81101 45 330 1108 URL: www.jp.sgs.com

Member of the SGS Group (Société Générale de Surveillance)



TEST REPORT

REPORT NO. JP/2017/111101

DATE: January 12, 2018

PAGE: 4 OF 4

KYOCERA CORPORATION

1810 TAKI-CHO SATSUMASENDAI-SHI KAGOSHIMA JAPAN

SAMPLE IMAGE



<END>

This Test Report is issued by the Company under its General Conditions of Service printed overleaf or available on request and accessible at <http://www.sgs.com>. Attention is drawn to the limitation of liability, indemnification and jurisdiction issues defined therein. Unless otherwise stated the results shown in this Test Report refer only to the samples tested. This Test Report cannot be reproduced except in full, without prior approval of the Company. Any unauthorized alteration, forgery or falsification of the content or appearance of this test report is unlawful and offenders may be prosecuted to the fullest extent of the law.

この検査報告書は表紙に記載された、もしくは<http://www.sgs.com>で入手可能なサービスに関する一般約款に準じて発行されます。それらに明記されている弊社のあらゆる義務・権利の範囲及び対応費の項目をご確認ください。他に特に明記のない限り、この検査報告書に記載された結果は、検査した試料のみに基づきます。この報告書全体の複製以外には、弊社からの事前の許可を得ること無く複製することを禁じます。この検査報告書を無断で複製、偽造、改ざんすることは違法であり、違反者に対しては法的な手段を講ずることとなります。

JP

SGS Japan Inc. | YBP East Tower 12F, 134 Godo-cho Hodogaya-ku Yokohama 240-0005, Japan
t +81(0) 45 330 1100 f +81(0) 45 330 1108 URL: www.jp.sgs.com

Member of the SGS Group Société Générale de Surveillance

13-3. RAW MATERIAL(LT WAFER)



For Question
Please Contact with SGS
www.sgs.com.tw

Test Report

No. : CE/2017/A5173

Date : 2017/11/01

Page : 1 of 9

Shin-Etsu Chemical Co.,Ltd.
13-1,Isobe 2-chome, Annaka-Shi, Gunma, Japan



The following samples was/were submitted and identified by/on behalf of the applicant as :

Sample Submitted By : Shin-Etsu Chemical Co.,Ltd.
Sample Description : BLT
Lot No : 79399A
Composition : Lithium Tantalate
Sample Receiving Date : 2017/10/26
Testing Period : 2017/10/26 TO 2017/11/01

Test Requested

- (1) As specified by client, with reference to RoHS 2011/65/EU Annex II and amending Directive (EU) 2015/863 to determine Cadmium, Lead, Mercury, Cr(VI), PBBs, PBDEs, DBP, BBP, DEHP, DIBP contents in the submitted sample(s).
- (2) Please refer to next pages for the other item(s).

Test Result(s) : Please refer to following pages.

Conclusion : (1) Based on the performed tests on submitted sample(s), the test results of Cadmium, Lead, Mercury, Cr(VI), PBBs, PBDEs, DBP, BBP, DEHP, DIBP comply with the limits as set by RoHS and amending Directive (EU) 2015/863.

Troy Chang, Manager - Tech
Signed for and on behalf of
SGS TAIWAN LTD.
Chemical Laboratory - Taipei



This document is issued by the Company subject to its General Conditions of Service printed overleaf, available on request or accessible at <http://www.sgs.com.tw/terms-and-conditions.aspx> and, for electronic format documents, subject to Terms and Conditions for Electronic Documents at <http://www.sgs.com.tw/terms-and-conditions/term-document.aspx>. Attention is drawn to the limitation of liability, indemnification and jurisdiction issues defined therein. Any holder of this document is advised that information contained hereon reflects the Company's findings at the time of its intervention only and within the limits of client's instruction, if any. The Company's sole responsibility is to its Client and this document does not exonerate parties to a transaction from exercising all their rights and obligations under the transaction documents. This document cannot be reproduced, except in full, without prior written approval of the Company. Any unauthorized alteration, forgery or falsification of the content or appearance of this document is unlawful and offenders may be prosecuted to the fullest extent of the law. Unless otherwise stated the results shown in this test report refer only to the sample(s) tested.

SGS Taiwan Ltd. 台灣檢驗科技股份有限公司 | 25, Wu Chuan 7th Road, New Taipei Industrial Park, Wu Ku District, New Taipei City, Taiwan (新北市五股區新北大業路七號25號) | t+886 (0)2239 3939 f+886 (0)2239 3232 www.sgs.tw

Member of the SGS Group



Test Report

No. : CE/2017/A5173

Date : 2017/11/01

Page : 2 of 9

Shin-Etsu Chemical Co.,Ltd.
13-1,Isobe 2-chome, Annaka-Shi, Gunma, Japan



Test Result(s)

PART NAME No.1 : WAFER

Test Item(s)	Unit	Method	MDL	Result	Limit
				No.1	
Cadmium (Cd)	mg/kg	With reference to IEC 62321-5 (2013) and performed by ICP-AES.	2	n.d.	100
Lead (Pb)	mg/kg	With reference to IEC 62321-5 (2013) and performed by ICP-AES.	2	n.d.	1000
Mercury (Hg)	mg/kg	With reference to IEC 62321-4 (2013) and performed by ICP-AES.	2	n.d.	1000
Hexavalent Chromium Cr(VI)	mg/kg	With reference to IEC 62321-7-2 (2017) and performed by UV-VIS.	8	n.d.	1000
Sum of PBBs	mg/kg		-	n.d.	1000
Monobromobiphenyl	mg/kg		5	n.d.	-
Dibromobiphenyl	mg/kg		5	n.d.	-
Tribromobiphenyl	mg/kg		5	n.d.	-
Tetrabromobiphenyl	mg/kg		5	n.d.	-
Pentabromobiphenyl	mg/kg		5	n.d.	-
Hexabromobiphenyl	mg/kg		5	n.d.	-
Heptabromobiphenyl	mg/kg		5	n.d.	-
Octabromobiphenyl	mg/kg		5	n.d.	-
Nonabromobiphenyl	mg/kg		5	n.d.	-
Decabromobiphenyl	mg/kg	With reference to IEC 62321-6 (2015) and performed by GC/MS.	5	n.d.	-
Sum of PBDEs	mg/kg		-	n.d.	1000
Monobromodiphenyl ether	mg/kg		5	n.d.	-
Dibromodiphenyl ether	mg/kg		5	n.d.	-
Tribromodiphenyl ether	mg/kg		5	n.d.	-
Tetrabromodiphenyl ether	mg/kg		5	n.d.	-
Pentabromodiphenyl ether	mg/kg		5	n.d.	-
Hexabromodiphenyl ether	mg/kg		5	n.d.	-
Heptabromodiphenyl ether	mg/kg		5	n.d.	-
Octabromodiphenyl ether	mg/kg		5	n.d.	-
Nonabromodiphenyl ether	mg/kg		5	n.d.	-
Decabromodiphenyl ether	mg/kg		5	n.d.	-

This document is issued by the Company subject to its General Conditions of Service printed overleaf, available on request or accessible at <http://www.sgs.com.tw/Terms-and-Conditions.aspx> and, for electronic format documents, subject to Terms and Conditions for Electronic Documents at <http://www.sgs.com.tw/Terms-and-Conditions/ETerminalDocument.aspx>. Attention is drawn to the limitation of liability, indemnification and jurisdiction issues defined therein. Any holder of this document is advised that information contained hereon reflects the Company's findings at the time of its intervention only and within the limits of client's instruction, if any. The Company's sole responsibility is to its Client and this document does not exonerate parties to a transaction from exercising all their rights and obligations under the transaction documents. This document cannot be reproduced, except in full, without prior written approval of the Company. Any unauthorized alteration, forgery or falsification of the content or appearance of this document is unlawful and offenders may be prosecuted to the fullest extent of the law. Unless otherwise stated the results shown in this test report refer only to the sample(s) tested.

SGS Taiwan Ltd. 台灣檢驗科技股份有限公司 | 25, Wu Chuan 7th Road, New Taipei Industrial Park, Wu Ku District, New Taipei City, Taiwan (新北市五股區新北產業園區五權七路25號)
t+886 (0)22391 3939 f+886 (0)22391 3237 www.sgs.tw

Member of the SGS Group



Test Report

No. : CE/2017/A5173

Date : 2017/11/01

Page : 3 of 9

Shin-Etsu Chemical Co.,Ltd.
13-1,Isobe 2-chome, Annaka-Shi, Gunma, Japan



Test Item(s)	Unit	Method	MDL	Result	Limit
				No.1	
BBP (Butyl Benzyl phthalate) (CAS No.: 85-68-7)	mg/kg	With reference to IEC 62321-8 (2017). Analysis was performed by GC/MS.	50	n.d.	1000
DBP (Dibutyl phthalate) (CAS No.: 84-74-2)	mg/kg	With reference to IEC 62321-8 (2017). Analysis was performed by GC/MS.	50	n.d.	1000
DEHP (Di- (2-ethylhexyl) phthalate) (CAS No.: 117-81-7)	mg/kg	With reference to IEC 62321-8 (2017). Analysis was performed by GC/MS.	50	n.d.	1000
DIBP (Di-isobutyl phthalate) (CAS No.: 84-69-5)	mg/kg	With reference to IEC 62321-8 (2017). Analysis was performed by GC/MS.	50	n.d.	1000
Halogen-Chlorine (Cl) (CAS No.: 22537-15-1)	mg/kg	With reference to BS EN 14582 (2016). Analysis was performed by IC.	50	n.d.	-
Halogen-Bromine (Br) (CAS No.: 10097-32-2)	mg/kg	With reference to BS EN 14582 (2016). Analysis was performed by IC.	50	n.d.	-
Antimony (Sb)	mg/kg	With reference to US EPA 3052 (1996). Analysis was performed by ICP-AES.	2	n.d.	-
Beryllium (Be)	mg/kg	With reference to US EPA 3052 (1996). Analysis was performed by ICP-AES.	2	n.d.	-

Note :

1. mg/kg = ppm ; 0.1wt% = 1000ppm
2. MDL = Method Detection Limit
3. n.d. = Not Detected = less than MDL
4. " - " = Not Regulated

This document is issued by the Company subject to its General Conditions of Service printed overleaf, available on request or accessible at <http://www.sgs.com.tw/terms-and-conditions.aspx> and, for electronic format documents, subject to Terms and Conditions for Electronic Documents at <http://www.sgs.com.tw/terms-and-conditions-for-electronic-document.aspx>. Attention is drawn to the limitation of liability, indemnification and jurisdiction issues defined therein. Any holder of this document is advised that information contained hereon reflects the Company's findings at the time of its intervention only and within the limits of client's instruction, if any. The Company's sole responsibility is to its Client and this document does not exonerate parties to a transaction from exercising all their rights and obligations under the transaction documents. This document cannot be reproduced, except in full, without prior written approval of the Company. Any unauthorized alteration, forgery or falsification of the content or appearance of this document is unlawful and offenders may be prosecuted to the fullest extent of the law. Unless otherwise stated the results shown in this test report refer only to the sample(s) tested.

SGS Taiwan Ltd. 台灣檢驗科技股份有限公司 | 25, Wu Chyuan 7th Road, New Taipei Industrial Park, Wu Ku District, New Taipei City, Taiwan (新北市五股區新北產業園區七樓七路25號)
+886 (0)22299 3939 +886 (0)22299 3237 www.sgs.tw

Member of the SGS Group



Test Report

No. : CE/2017/A5173

Date : 2017/11/01

Page : 4 of 9

Shin-Etsu Chemical Co.,Ltd.
 13-1,Isobe 2-chome, Annaka-Shi, Gunma, Japan



Analytical flow chart of Heavy Metal

These samples were dissolved totally by pre-conditioning method according to below flow chart. (Cr⁶⁺ test method excluded)

- Technician : JR Wang
- Supervisor: Troy Chang

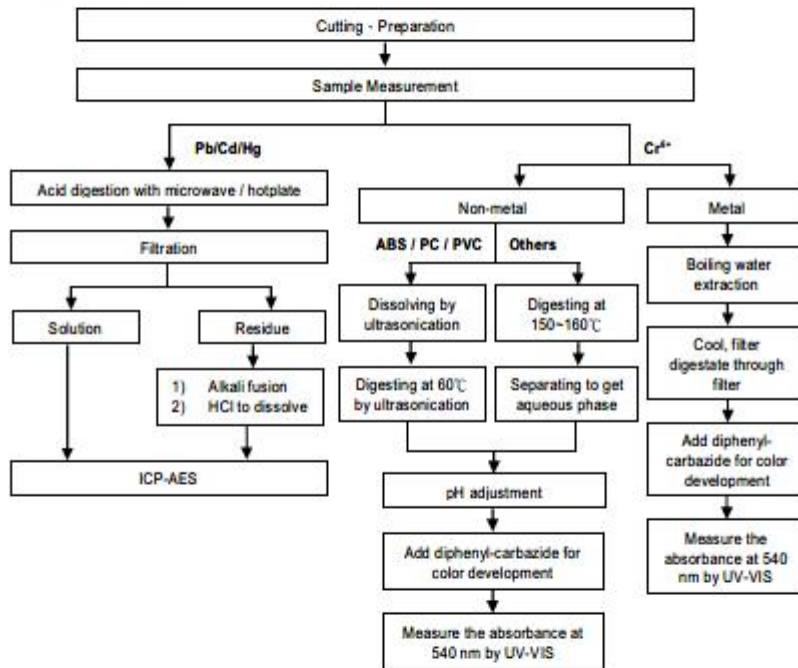

This document is issued by the Company subject to its General Conditions of Service printed overleaf, available on request or accessible at <http://www.sgs.com.tw/terms-and-conditions> and, for electronic format documents, subject to Terms and Conditions for Electronic Documents at <http://www.sgs.com.tw/terms-and-conditions>. Attention is drawn to the limitation of liability, indemnification and jurisdiction issues defined therein. Any holder of this document is advised that information contained herein reflects the Company's findings at the time of its intervention only and within the limits of client's instruction, if any. The Company's sole responsibility is to its Client and this document does not exonerate parties to a transaction from exercising all their rights and obligations under the transaction documents. This document cannot be reproduced, except in full, without prior written approval of the Company. Any unauthorized alteration, forgery or fabrication of the content or appearance of this document is unlawful and offenders may be prosecuted to the fullest extent of the law. Unless otherwise stated the results shown in this test report refer only to the sample(s) tested.



Test Report

No. : CE/2017/A5173

Date : 2017/11/01

Page : 5 of 9

Shin-Etsu Chemical Co.,Ltd.
 13-1,Isobe 2-chome, Annaka-Shi, Gunma, Japan



These samples were dissolved totally by pre-conditioning method according to below flow chart.

- Technician: JR Wang
- Supervisor: Troy Chang

Flow Chart of digestion for the elements analysis performed by ICP-AES

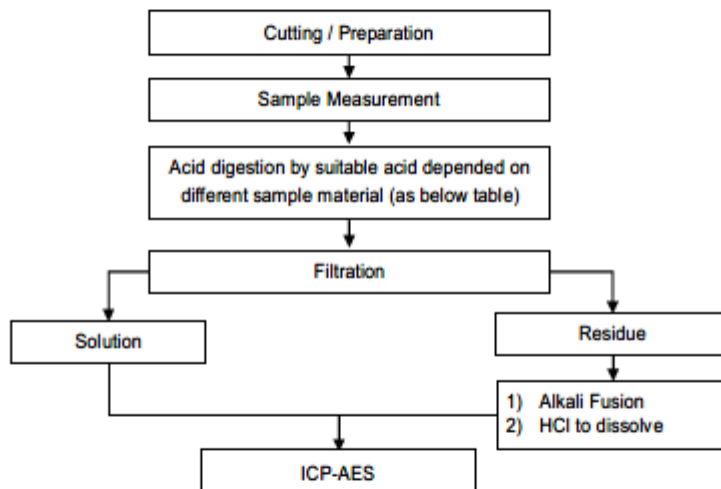

Steel, copper, aluminum, solder	Aqua regia, HNO ₃ , HCl, HF, H ₂ O ₂
Glass	HNO ₃ /HF
Gold, platinum, palladium, ceramic	Aqua regia
Silver	HNO ₃
Plastic	H ₂ SO ₄ , H ₂ O ₂ , HNO ₃ , HCl
Others	Added appropriate reagent to total digestion

This document is issued by the Company subject to its General Conditions of Service printed overleaf, available on request or accessible at <http://www.sgs.com.tw/Terms-and-Conditions.aspx> and, for electronic format documents, subject to Terms and Conditions for Electronic Documents at <http://www.sgs.com.tw/Terms-and-Conditions/etcdm/Document.aspx>. Attention is drawn to the limitation of liability, indemnification and jurisdiction issues defined therein. Any holder of this document is advised that information contained hereon reflects the Company's findings at the time of its intervention only and within the limits of client's instruction, if any. The Company's sole responsibility is to its Client and this document does not exonerate parties to a transaction from exercising all their rights and obligations under the transaction documents. This document cannot be reproduced, except in full, without prior written approval of the Company. Any unauthorized alteration, forgery or falsification of the content or appearance of this document is unlawful and offenders may be prosecuted to the fullest extent of the law. Unless otherwise stated the results shown in this test report refer only to the sample(s) tested.

SGS Taiwan Ltd. 台灣檢驗科技股份有限公司 | 25, Wu Chyan 7th Road, New Taipei Industrial Park, Wu Ku District, New Taipei City, Taiwan (新北市五股區新北大道七段25號) | +886 (0)2(2)991-3939 | +886 (0)2(2)991-3237 | www.sgs.tw

Member of the SGS Group



Test Report

No. : CE/2017/A5173

Date : 2017/11/01

Page : 6 of 9

Shin-Etsu Chemical Co.,Ltd.

13-1,Isobe 2-chome, Annaka-Shi, Gunma, Japan



Analytical flow chart - Halogen

- Technician: Rita Chen
- Supervisor: Troy Chang

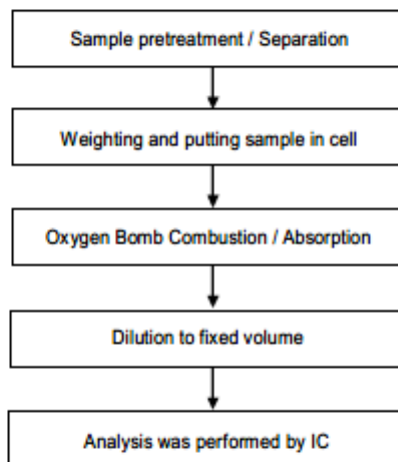

This document is issued by the Company subject to its General Conditions of Service printed overleaf, available on request or accessible at <http://www.sgs.com/en/Terms-and-Conditions.aspx> and, for electronic format documents, subject to Terms and Conditions for Electronic Documents at <http://www.sgs.com/en/Terms-and-Conditions/etm/etm-document.aspx>. Attention is drawn to the limitation of liability, indemnification and jurisdiction issues defined therein. Any holder of this document is advised that information contained herein reflects the Company's findings at the time of its intervention only and within the limits of client's instruction, if any. The Company's sole responsibility is to its Client and this document does not exonerate parties to a transaction from exercising all their rights and obligations under the transaction documents. This document cannot be reproduced, except in full, without prior written approval of the Company. Any unauthorized alteration, forgery or falsification of the content or appearance of this document is unlawful and offenders may be prosecuted to the fullest extent of the law. Unless otherwise stated the results shown in this test report refer only to the sample(s) tested.

SGS Taiwan Ltd. 台灣檢驗科技股份有限公司 | 25, Wu Chuan 7th Road, New Taipei Industrial Park, Wu Ku District, New Taipei City, Taiwan (新北市五股區新北大業街五樓七號) | +886 (0)22399 3939 | +886 (0)22399 3237 | www.sgs.tw

Member of the SGS Group



Test Report

No. : CE/2017/A5173

Date : 2017/11/01

Page : 7 of 9

Shin-Etsu Chemical Co.,Ltd.

13-1,Isobe 2-chome, Annaka-Shi, Gunma, Japan



Analytical flow chart - Phthalate

- Technician: Andy Hsu
- Supervisor: Troy Chang

【Test method: IEC 62321-8】

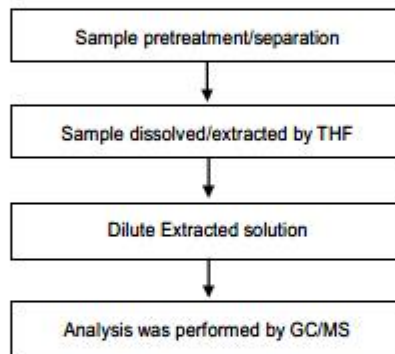

This document is issued by the Company subject to its General Conditions of Service printed overleaf, available on request or accessible at <http://www.sgs.com.tw/TermsandConditions.aspx> and, for electronic format documents, subject to Terms and Conditions for Electronic Documents at <http://www.sgs.com.tw/TermsandConditions/ElectronicDocuments.aspx>. Attention is drawn to the limitation of liability, indemnification and jurisdiction issues defined therein. Any holder of this document is advised that information contained hereon reflects the Company's findings as the time of its intervention only and within the limits of client's instruction, if any. The Company's sole responsibility is to its Client and this document does not constitute parties to a transaction from exercising all their rights and obligations under the transaction documents. This document cannot be reproduced, except in full, without prior written approval of the Company. Any unauthorized alteration, forgery or falsification of the content or appearance of this document is unlawful and offenders may be prosecuted to the fullest extent of the law. Unless otherwise stated the results shown in this test report refer only to the sample(s) tested.

SGS Taiwan Ltd. 台灣檢驗科技股份有限公司 | 25, Wu Chyuan 7th Road, New Taipei Industrial Park, Wu Ku District, New Taipei City, Taiwan (新北市五股區新台北產業園區五權七路25號) | +886 (0)22399 3939 | +886 (0)2239 3237 | www.sgs.tw

Member of the SGS Group



Test Report

No. : CE/2017/A5173

Date : 2017/11/01

Page : 8 of 9

Shin-Etsu Chemical Co.,Ltd.

13-1,Isobe 2-chome, Annaka-Shi, Gunma, Japan



Analytical flow chart – PBB / PBDE

- Technician : Yaling Tu
- Supervisor: Troy Chang

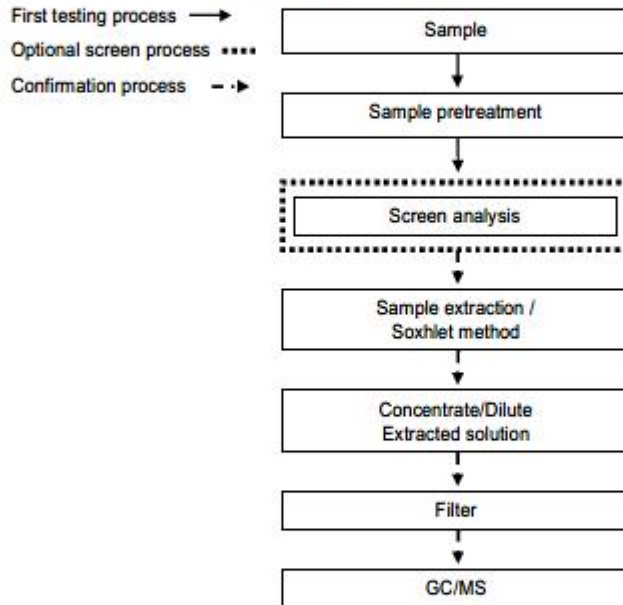

This document is issued by the Company subject to its General Conditions of Service printed overleaf, available on request or accessible at http://www.sgs.com.tw/Terms_and_Conditions.aspx and, for electronic format documents, subject to Terms and Conditions for Electronic Documents at http://www.sgs.com.tw/Electronic_Documents.aspx. Attention is drawn to the limitation of liability, indemnification and jurisdiction issues defined therein. Any holder of this document is advised that information contained hereon reflects the Company's findings at the time of its intervention only and within the limits of client's instruction, if any. The Company's sole responsibility is to its Client and this document does not exonerate parties to a transaction from exercising all their rights and obligations under the transaction documents. This document cannot be reproduced, except in full, without prior written approval of the Company. Any unauthorized alteration, forgery or falsification of the content or appearance of this document is unlawful and offenders may be prosecuted to the fullest extent of the law. Unless otherwise stated the results shown in this test report refer only to the sample(s) tested.

SGS Taiwan Ltd. 台灣檢驗科技股份有限公司 | 25, Wu Chyuan 7th Road, New Taipei Industrial Park, Wu Ku District, New Taipei City, Taiwan (新北市五股區新五路七號25號) | +886 (0)2(2)99-3939 | +886 (0)2(2)99-3237 | www.sgs.tw

Member of the SGS Group

13-4. RAW MATERIAL(GOLD WIRE)



Test Report

No. SHAEC1718798806

Date: 31 Aug 2017

Page 1 of 23

TANAKA ELECTRONICS (HANGZHOU) CO.,LTD.

F1 AREA, WEST NO.19 STREET, NORTH NO.10 STREET, HANGZHOU ECONOMIC&TECHNOLOGICAL DEVELOPMENT ZONE,HANGZHOU

The following sample(s) was/were submitted and identified on behalf of the clients as : Au Bonding Wire

SGS Job No. : SP17-030384 - SH

Date of Sample Received : 25 Aug 2017

Testing Period : 25 Aug 2017 - 31 Aug 2017

Test Requested : Selected test(s) as requested by client.

Test Method : Please refer to next page(s).

Test Results : Please refer to next page(s).

Conclusion : Based on the performed tests on submitted sample(s), the results of Lead, Mercury, Cadmium, Hexavalent chromium, Polybrominated biphenyls (PBBs), Polybrominated diphenyl ethers (PBDEs) and Phthalates such as Bis(2-ethylhexyl) phthalate (DEHP), Butyl benzyl phthalate (BBP), Dibutyl phthalate (DBP) and Diisobutyl phthalate (DIBP) comply with the limits as set by RoHS Directive (EU) 2015/863 amending Annex II to Directive 2011/65/EU.

When tested as specified, Dimethyl fumarate(DMF) content of the submitted sample comply with Commission Regulation (EU) No 412/2012 and Entry 61 of Annex XVII of REACH Regulation (EC) No 1907/2006

Signed for and on behalf of
SGS-CSTC Standards Technical Services (Shanghai) Co., Ltd.



Marry Ma
Approved Signatory



Unless otherwise agreed in writing, this document is issued by the Company subject to its General Conditions of Service printed overleaf, available on request or accessible at <http://www.sgs.com/en/Terms-and-Conditions.aspx> and, for electronic format documents, subject to Terms and Conditions for Electronic Documents at <http://www.sgs.com/en/Terms-and-Conditions/Terms-e-Document.aspx>. Attention is drawn to the limitation of liability, indemnification and jurisdiction issues defined therein. Any holder of this document is advised that information contained herein reflects the Company's findings at the time of its intervention only and within the limits of Client's instructions, if any. The Company's sole responsibility is to its Client and this document does not exonerate parties to a transaction from exercising all their rights and obligations under the transaction documents. This document cannot be reproduced except in full, without prior written approval of the Company. Any unauthorized alteration, forgery or falsification of the content or appearance of this document is unlawful and offenders may be prosecuted to the fullest extent of the law. Unless otherwise stated the results shown in this test report refer only to the sample(s) tested.

Attention: To check the authenticity of testing inspection report & certificate, please contact us at telephone: (86-755) 8387 1443, or email: CN_02cchc@sgs.com
 3rd Building No. 839 Yixian Road Xuhui District Shanghai China 200233 1 EAE (86-21) 61402553 1 EAE (86-21) 64953679 www.sgs.com.cn
 中国·上海·徐汇区宜山路839号3号楼 邮编: 200233 1 HL (86-21) 61402594 1 HL (86-21) 61150899 e: sgs.china@sgs.com

Member of the SGS Group (SGS SA)

Test Report

No. SHAEC1718798806

Date: 31 Aug 2017

Page 2 of 23

Test Results :

Test Part Description :

Specimen No.	SGS Sample ID	Description
SN1	SHA17-187988.003	Golden metal wire

Remarks :

- (1) 1 mg/kg = 1 ppm = 0.0001%
- (2) MDL = Method Detection Limit
- (3) ND = Not Detected (< MDL)
- (4) "-" = Not Regulated

RoHS Directive (EU) 2015/863 amending Annex II to Directive 2011/65/EU

Test Method : With reference to IEC 62321-4:2013, IEC62321-5:2013, IEC 62321-7-1:2015, IEC 62321-6:2015 and IEC62321-8:2017, analyzed by ICP-OES/AAS, UV-Vis and GC-MS.

Test Item(s)	Limit	Unit	MDL	003
Cadmium (Cd)	100	mg/kg	2	ND
Lead (Pb)	1000	mg/kg	2	ND
Mercury (Hg)	1000	mg/kg	2	ND
Hexavalent Chromium (Cr(VI)) [▼]	-	µg/cm ²	0.10	ND
Sum of PBBs	1000	mg/kg	-	ND
Monobromobiphenyl	-	mg/kg	5	ND
Dibromobiphenyl	-	mg/kg	5	ND
Tribromobiphenyl	-	mg/kg	5	ND
Tetrabromobiphenyl	-	mg/kg	5	ND
Pentabromobiphenyl	-	mg/kg	5	ND
Hexabromobiphenyl	-	mg/kg	5	ND
Heptabromobiphenyl	-	mg/kg	5	ND
Octabromobiphenyl	-	mg/kg	5	ND
Nonabromobiphenyl	-	mg/kg	5	ND
Decabromobiphenyl	-	mg/kg	5	ND
Sum of PBDEs	1000	mg/kg	-	ND
Monobromodiphenyl ether	-	mg/kg	5	ND
Dibromodiphenyl ether	-	mg/kg	5	ND
Tribromodiphenyl ether	-	mg/kg	5	ND
Tetrabromodiphenyl ether	-	mg/kg	5	ND



Unless otherwise agreed in writing, this document is issued by the Company subject to its General Conditions of Service printed overleaf, available on request or accessible at <http://www.sgs.com/en/Terms-and-Conditions.aspx> and, for electronic format documents, subject to Terms and Conditions for Electronic Documents at <http://www.sgs.com/en/Terms-and-Conditions/Terms-e-Documents.aspx>. Attention is drawn to the limitation of liability, indemnification and jurisdiction issues defined therein. Any holder of this document is advised that information contained hereon reflects the Company's findings at the time of its intervention only and within the limits of Client's instructions, if any. The Company's sole responsibility is to its Client and this document does not exonerate parties to a transaction from exercising all their rights and obligations under the transaction documents. This document cannot be reproduced except in full, without prior written approval of the Company. Any unauthorized alteration, forgery or falsification of the content or appearance of this document is unlawful and offenders may be prosecuted to the fullest extent of the law. Unless otherwise stated the results shown in this test report refer only to the sample(s) tested.

Attention: To check the authenticity of testing / inspection report & certificate, please contact us at telephone: (86-755) 8387 1443, or email: CN.Doccheck@sgs.com

SGS (China) Inspection & Testing Services Co., Ltd. 3rd Building, No. 889 Yehen Road Xuhui District, Shanghai China 200233 TEL (86-21) 61402553 FAX (86-21) 64953679 www.sgs.com.cn
 中国·上海·徐汇区宜山路889号3号楼 邮编: 200233 TEL (86-21) 61402594 FAX (86-21) 61198999 e sgs.china@sgs.com

Member of the SGS Group (SGS SA)

Test Report

No. SHAEC1718798806

Date: 31 Aug 2017

Page 3 of 23

<u>Test Item(s)</u>	<u>Limit</u>	<u>Unit</u>	<u>MDL</u>	<u>003</u>
Pentabromodiphenyl ether	-	mg/kg	5	ND
Hexabromodiphenyl ether	-	mg/kg	5	ND
Heptabromodiphenyl ether	-	mg/kg	5	ND
Octabromodiphenyl ether	-	mg/kg	5	ND
Nonabromodiphenyl ether	-	mg/kg	5	ND
Decabromodiphenyl ether	-	mg/kg	5	ND
Di-butyl Phthalate (DBP)	1000	mg/kg	50	ND
Benzyl Butyl Phthalate (BBP)	1000	mg/kg	50	ND
Di-2-Ethyl Hexyl Phthalate (DEHP)	1000	mg/kg	50	ND
Diisobutyl Phthalates (DIBP)	1000	mg/kg	50	ND

Notes :

- (1) The maximum permissible limit is quoted from RoHS Directive (EU) 2015/863. IEC 62321 series is equivalent to EN 62321 series
http://www.cenelec.eu/dyn/www/f?p=104:30:1742232870351101:::FSP_ORG_ID,FSP_LANG_ID:1258637,25
- (2) \neq a. The sample is positive for CrVI if the CrVI concentration is greater than 0.13 $\mu\text{g}/\text{cm}^2$. The sample coating is considered to contain CrVI
 b. The sample is negative for CrVI if CrVI is ND (concentration less than 0.10 $\mu\text{g}/\text{cm}^2$). The coating is considered a non-CrVI based coating
 c. The result between 0.10 $\mu\text{g}/\text{cm}^2$ and 0.13 $\mu\text{g}/\text{cm}^2$ is considered to be inconclusive - unavoidable coating variations may influence the determination

Information on storage conditions and production date of the tested sample is unavailable and thus Cr(VI) results represent status of the sample at the time of testing.

Halogen

Test Method : With reference to EN 14582: 2007, analysis was performed by Ion Chromatograph (IC).

<u>Test Item(s)</u>	<u>Unit</u>	<u>MDL</u>	<u>003</u>
Fluorine (F)	mg/kg	50	ND
Chlorine (Cl)	mg/kg	50	ND
Bromine (Br)	mg/kg	50	ND
Iodine (I)	mg/kg	50	ND

Element(s)

Test Method : With reference to US EPA Method 3050B:1996, analysis was performed by ICP-OES.



Unless otherwise agreed in writing, this document is issued by the Company subject to its General Conditions of Service printed overleaf, available on request or accessible at <http://www.sgs.com/en/Terms-and-Conditions.aspx> and, for electronic format documents, subject to Terms and Conditions for Electronic Documents at <http://www.sgs.com/en/Terms-and-Conditions/Terms-e-Documents.aspx>. Attention is drawn to the limitation of liability, indemnification and jurisdiction issues defined therein. Any holder of this document is advised that information contained hereon reflects the Company's findings at the time of its intervention only and within the limits of Client's instructions, if any. The Company's sole responsibility is to its Client and this document does not exonerate parties to a transaction from exercising all their rights and obligations under the transaction documents. This document cannot be reproduced except in full, without prior written approval of the Company. Any unauthorized alteration, forgery or falsification of the content or appearance of this document is unlawful and offenders may be prosecuted to the fullest extent of the law. Unless otherwise stated the results shown in this test report refer only to the sample(s) tested.

Attention: To check the authenticity of testing/inspection report & certificate, please contact us at telephone: (86-755) 8187 1443, or email: CN.Doccheck@sgs.com

SGS-CSI (Shanghai) Inspection & Testing Services Co., Ltd.
 3rd Building, No. 859 Yahan Road Xuhui District, Shanghai China 200233 1E&E (86-21) 61402553 1E&E (86-21) 64953679 www.sgs.com.cn
 中国·上海·徐汇区宜山路859号3号楼 邮编: 200233 1HL (86-21) 61402594 1HL (86-21) 61159899 e.sgs.china@sgs.com

Member of the SGS Group (SGS SA)



Test Report

No. SHAEC1718798806

Date: 31 Aug 2017

Page 4 of 23

Test Item(s)	CAS NO.	Unit	MDL	003
Antimony (Sb)		mg/kg	10	ND
Beryllium (Be)		mg/kg	5	ND
Antimony trioxide (Sb ₂ O ₃)*		mg/kg	12	ND
Beryllium oxide (BeO) *		mg/kg	15	ND
Diarsenic trioxide (As ₂ O ₃) *	1327-53-3	mg/kg	10	ND
Arsenic (As)		mg/kg	10	ND
Diarsenic pentaoxide (As ₂ O ₅) *	1303-28-2	mg/kg	10	ND

Notes :

- (1) * Calculated concentration of BeO is based on the identified Be
 Calculated concentration of Sb₂O₃ is based on the identified Sb
 Calculated concentration of diarsenic pentaoxide and diarsenic trioxide are based on the identified arsenic and lead

Organic-tin compounds

Test Method : With reference to ISO 17353: 2004 with carbamate, analysis was performed by GC-MS.

Test Item(s)	Unit	MDL	003
Tributyl tin (TBT)	mg/kg	0.02	ND
Dibutyl tin (DBT)	mg/kg	0.02	ND
Diocetyl tin (DOT)	mg/kg	0.02	ND
Tripropyltin (TPT)	mg/kg	0.02	ND
Bis(tributyltin) oxide (TBTO) *	mg/kg	0.02	ND

Notes :

- (1) * = TBTO are back calculated based on the worst-case scenario of TBT

Polychlorinated Naphthalenes (PCNs)

Test Method : With reference to US EPA 8081B: 2007, analysis was performed by GC-MS

Test Item(s)	Unit	MDL	003
2-Chlorinated Naphthalene	mg/kg	5	ND
1,4-Dichlorinated Naphthalene	mg/kg	5	ND
1,5-Dichlorinated Naphthalene	mg/kg	5	ND
1,2-Dichlorinated Naphthalene	mg/kg	5	ND
1,8-Dichlorinated Naphthalene	mg/kg	5	ND



Unless otherwise agreed in writing, this document is issued by the Company subject to its General Conditions of Service printed overleaf, available on request or accessible at <http://www.sgs.com/en/Terms-and-Conditions.aspx> and, for electronic format documents, subject to Terms and Conditions for Electronic Documents at <http://www.sgs.com/en/Terms-and-Conditions/Terms-e-Documents.aspx>. Attention is drawn to the limitation of liability, indemnification and jurisdiction issues defined therein. Any holder of this document is advised that information contained hereon reflects the Company's findings at the time of its intervention only and within the limits of Client's instructions, if any. The Company's sole responsibility is to its Client and this document does not exonerate parties to a transaction from exercising all their rights and obligations under the transaction documents. This document cannot be reproduced except in full, without prior written approval of the Company. Any unauthorized alteration, forgery or falsification of the content or appearance of this document is unlawful and offenders may be prosecuted to the fullest extent of the law. Unless otherwise stated the results shown in this test report refer only to the sample(s) tested.

Attention: To check the authenticity of testing inspection report & certificate, please contact us at telephone: (86-755) 8387 1443, or email: CN.Doccheck@sgs.com

SGS-CSI (Shanghai) Inspection & Testing Services (Shanghai) Co., Ltd.
 3rd Building No. 885 Yitian Road Xuhui District, Shanghai China 200233 1E&E (86-21) 61402553 1E&E (86-21) 64953679 www.sgs.com.cn
 中国·上海·徐汇区宜山路885号3号楼 邮编: 200233 1HL (86-21) 61402594 1HL (86-21) 61109899 e sgs.china@sgs.com

Member of the SGS Group (SGS SA)



Test Report

No. SHAEC1718798806

Date: 31 Aug 2017

Page 5 of 23

<u>Test Item(s)</u>	<u>Unit</u>	<u>MDL</u>	<u>003</u>
1,2,3-Trichlorinated Naphthalene	mg/kg	5	ND
1,2,3,4-Tetrachlorinated Naphthalene	mg/kg	5	ND
1,2,3,4,6-Pentachlorinated Naphthalene	mg/kg	5	ND
Octa-chlorinaed Naphthalene	mg/kg	5	ND
1-Chlorinated Naphthalene	mg/kg	5	ND

Short-chain Chlorinated Paraffin (SCCP) and Medium-chain Chlorinated Paraffin (MCCP)

Test Method : With reference to US EPA 3550C: 2007, analysis was performed by GC-ECD / GC-NCI-MS

<u>Test Item(s)</u>	<u>Unit</u>	<u>MDL</u>	<u>003</u>
Short-chain Chlorinated Paraffin (SCCP) (C ₁₀ -C ₁₃)	mg/kg	50	ND
Medium-chain Chlorinated Paraffin (MCCP) (C ₁₄ -C ₁₇)	mg/kg	50	ND

Red Phosphorus

Test Method : SGS in house method(SHTC- CHEM- SOP -342-T), Analysis was performed by ICP-OES and Pyrolysis-GC/MS

<u>Test Item(s)</u>	<u>Unit</u>	<u>MDL</u>	<u>003</u>
Red Phosphorus	mg/kg	500	ND

Notes :

For Positive result, the testing result is based on the worst-case scenario, and confirmed by Pyrolysis-GC-MS.

Tetrabromobisphenol A (TBBP-A)

Test Method : With reference to US EPA 3540C: 1996, analysis was performed by GC-MS.

<u>Test Item(s)</u>	<u>Unit</u>	<u>MDL</u>	<u>003</u>
Tetrabromobisphenol A (TBBP-A)	mg/kg	10	ND



Unless otherwise agreed in writing, this document is issued by the Company subject to its General Conditions of Service printed overleaf, available on request or accessible at <http://www.sgs.com/en/Terms-and-Conditions.aspx> and, for electronic format documents, subject to Terms and Conditions for Electronic Documents at <http://www.sgs.com/en/Terms-and-Conditions/Terms-e-Documents.aspx>. Attention is drawn to the limitation of liability, indemnification and jurisdiction issues defined therein. Any holder of this document is advised that information contained hereon reflects the Company's findings at the time of its intervention only and within the limits of Client's instructions, if any. The Company's sole responsibility is to its Client and this document does not constitute parties to a transaction from executing all their rights and obligations under the transaction documents. This document cannot be reproduced except in full, without prior written approval of the Company. Any unauthorized alteration, forgery or falsification of the content or appearance of this document is unlawful and offenders may be prosecuted to the fullest extent of the law. Unless otherwise stated the results shown in this test report refer only to the sample(s) tested.
 Attention: To check the authenticity of testing/inspection report & certificate, please contact us at telephone: (86-755) 8387 1443, or email: CN.Doccheck@sgs.com
 SGS-CTI (China) Service S.p.A. (Incorporated in Italy) / SGS-CTI (China) Service S.p.A. (Incorporated in Italy)
 3rd Building, No. 859 Yaran Road, Xuhui District, Shanghai, China 200233 | E&E (86-21) 61402553 | E&E (86-21) 64863679 | www.sgs.com.cn
 中国·上海·徐汇区宜山路859号3号楼 邮编: 200233 | IHL (86-21) 61402594 | IHL (86-21) 61150899 | e.sgs.china@sgs.com

Member of the SGS Group (SGS SA)

Test Report

No. SHAEC1718798806

Date: 31 Aug 2017

Page 6 of 23

PVC (Polyvinyl chloride)

Test Method : In-house method (SHTC-CHEM-SOP-115-T), analysis was performed by FTIR/HATR.

Test Item(s)	CAS NO.	Unit	MDL	003
PVC	9002-86-2	-	-	Negative

Notes :

(1) Negative=Undetectable,Positive=Detectable

Bisphenol-A

Test Method : Extraction by organic solvent, analysis by HPLC-DAD-MS.

Test Item(s)	Unit	MDL	003
Bisphenol-A	mg/kg	1	ND

Commission Regulation (EU) No 412/2012 and Entry 61 of Annex XVII of REACH Regulation (EC) No 1907/2006 - Dimethyl fumarate(DMF)

Test Method : Solvent extraction, analysis was performed by GC-MS.

Test Item(s)	Limit	Unit	MDL	003
Dimethyl fumarate(DMF)	0.1	mg/kg	0.1	ND

Polychlorinated Terphenyls (PCTs)

Test Method : With reference to US EPA 8082A: 2007, analysis was performed by GC-MS

Test Item(s)	Unit	MDL	003
Aroclor 5432	mg/kg	5	ND
Aroclor 5442	mg/kg	5	ND

Hexabromocyclododecane (HBCDD)

Test Method : With reference to IEC 62321:2008, analysis was performed by GC-MS.



Unless otherwise agreed in writing, this document is issued by the Company subject to its General Conditions of Service printed overleaf, available on request or accessible at <http://www.sgs.com/en/Terms-and-Conditions.aspx> and, for electronic format documents, subject to Terms and Conditions for Electronic Documents at <http://www.sgs.com/en/Terms-and-Conditions/Terms-e-Documents.aspx>. Attention is drawn to the limitation of liability, indemnification and jurisdiction issues defined therein. Any holder of this document is advised that information contained hereon reflects the Company's findings at the time of its intervention only and within the limits of Client's instructions, if any. The Company's sole responsibility is to its Client and this document does not exonerate parties to a transaction from exercising all their rights and obligations under the transaction documents. This document cannot be reproduced except in full, without prior written approval of the Company. Any unauthorized alteration, forgery or falsification of the content or appearance of this document is unlawful and offenders may be prosecuted to the fullest extent of the law. Unless otherwise stated the results shown in this test report refer only to the sample(s) tested.

Attention: To check the authenticity of testing (inspection report & certificate), please contact us at telephones: (86-755) 8387 1443, or email: CN_Docscheck@sgs.com

SGS-China Inspection & Testing Service (Pvt.) Co., Ltd. 3rd Building, No. 839 Yanan Road Xuhui District, Shanghai China 200233 1E&E (86-21) 61402553 1E&E (86-21) 64653679 www.sgs.com.cn
 中国·上海·徐汇区宜山路839号3号楼 邮编: 200233 1HL (86-21) 61402594 1HL (86-21) 61158999 e sgs.china@sgs.com

Member of the SGS Group (SGS SA)



Test Report

No. SHAEC1718798806

Date: 31 Aug 2017

Page 7 of 23

Test Item(s)	Unit	MDL	003
Hexabromocyclododecane (HBCDD)	mg/kg	10	ND

PFOS (Perfluorooctane Sulfonates) and PFOA (Perfluorooctanoic Acid)

Test Method : With reference to US EPA 3550C: 2007, analysis was performed by HPLC-MS.

Test Item(s)	Limit	Unit	MDL	003
Perfluorooctanesulfonate (PFOS) ^A	1000	mg/kg	10	ND
Perfluorooctanoic Acid (PFOA)	-	mg/kg	10	ND

Notes :

- (1) Max. limit specified by commission regulation (EU) No. 757/2010 amending regulation (EC) No 850/2004
- (2)^A PFOS refer to Perfluorooctanesulfonic acid and its derivatives including Perfluorooctanesulfonic acid, Perfluorooctane sulfonamide, N-Methylperfluorooctane sulfonamide, N-Ethylperfluorooctane sulfonamide, N-Methylperfluorooctane sulfonamidoethanol and N-Ethylperfluorooctane sulfonamidoethanol.

Polychlorinated Biphenyls (PCBs)

Test Method : With reference to US EPA 8082A: 2007, analysis was performed by GC-MS

Test Item(s)	CAS NO.	Unit	MDL	003
2,4,4'-Trichlorobiphenyl (PCB 28)	7012-37-5	mg/kg	0.5	ND
2,2',5,5'-Tetrachloro-biphenyl (PCB 52)	35693-99-3	mg/kg	0.5	ND
2,2',4,5,5'-Pentachloro-biphenyl (PCB 101)	37680-73-2	mg/kg	0.5	ND
2,3',4,4',5-Pentachlorobiphenyl (PCB 118)	31508-00-6	mg/kg	0.5	ND
2,2',3,4,4',5'-Hexachloro-biphenyl (PCB 138)	35065-28-2	mg/kg	0.5	ND
2,2',4,4',5,5'-Hexachloro-biphenyl (PCB 153)	35065-27-1	mg/kg	0.5	ND
2,2',3,4,4',5,5'-Heptachlorobiphenyl (PCB 180)	35065-29-3	mg/kg	0.5	ND

Phthalates Content

Test Method : With reference to IEC 62321-8 Ed.1.0 (111/321/CD) , determination of phthalates by GC-MS.

Test Item(s)	CAS NO.	Unit	MDL	003
Diisononyl Phthalate (DINP)	28553-12-0	mg/kg	50	ND
Di-n-octyl Phthalate (DNOP)	117-84-0	mg/kg	50	ND



Unless otherwise agreed in writing, this document is issued by the Company subject to its General Conditions of Service printed overleaf, available on request or accessible at <http://www.sgs.com/en/Terms-and-Conditions.aspx> and, for electronic format documents, subject to Terms and Conditions for Electronic Documents at <http://www.sgs.com/en/Terms-and-Conditions/Terms-of-Electronic-Documents.aspx>. Attention is drawn to the limitation of liability, indemnification and jurisdiction issues defined therein. Any holder of this document is advised that information contained hereon reflects the Company's findings at the time of its intervention only and within the limits of Client's instructions, if any. The Company's sole responsibility is to its Client and this document does not exonerate parties to a transaction from exercising all their rights and obligations under the transaction documents. This document cannot be reproduced except in full, without prior written approval of the Company. Any unauthorized alteration, forgery or falsification of the content or appearance of this document is unlawful and offenders may be prosecuted to the fullest extent of the law. Unless otherwise stated the results shown in this test report refer only to the sample(s) tested.

Attention: To check the authenticity of testing /inspection report & certificate, please contact us at telephones: (86-755) 8987 1443, or email: CN.Doccheck@sgs.com

SGS-CTI (Shanghai) Service Station (China) Co., Ltd. 3rd Building No. 889 Yishan Road Xuhui District, Shanghai China 200233 1E&E (86-21) 61402583 1E&E (86-21) 64653679 www.sgs.com.cn
 中国·上海·徐汇区宜山路889号3号楼 邮编: 200233 1HL (86-21) 61402584 1HL (86-21) 61150999 e sgs.china@sgs.com

Member of the SGS Group (SGS SA)



Test Report

No. SHAEC1718798806

Date: 31 Aug 2017

Page 8 of 23

Test Item(s)	CAS NO.	Unit	MDL	003
Diisodecyl Phthalate (DIDP)	26761-40-0	mg/kg	50	ND
	/68515-49-1			
Dihexyl Phthalates (DnHP)	84-75-3	mg/kg	50	ND
Diisooheptyl phthalate (DIHP)	71888-89-6	mg/kg	50	ND
1,2-Benzenedicarboxylic acid, di-C7-11-branched and linear alkyl esters(DHNUP)	68515-42-4	mg/kg	50	ND
Bis(2-methoxyethyl) Phthalate (DMEP)	117-82-8	mg/kg	50	ND



Unless otherwise agreed in writing, this document is issued by the Company subject to its General Conditions of Service printed overleaf, available on request or accessible at <http://www.sgs.com/en/Terms-and-Conditions.aspx> and, for electronic format documents, subject to Terms and Conditions for Electronic Documents at <http://www.sgs.com/en/Terms-and-Conditions/Terms-e-Document.aspx>. Attention is drawn to the limitation of liability, indemnification and jurisdiction issues defined therein. Any holder of this document is advised that information contained hereon reflects the Company's findings at the time of its intervention only and within the limits of Client's instructions, if any. The Company's sole responsibility is to its Client and this document does not constitute parties to a transaction from exercising all their rights and obligations under the transaction documents. This document cannot be reproduced except in full, without prior written approval of the Company. Any unauthorized alteration, forgery or falsification of the content or appearance of this document is unlawful and offenders may be prosecuted to the fullest extent of the law. Unless otherwise stated the results shown in this test report refer only to the sample(s) tested.

Attention: To check the authenticity of testing/inspection report & certificate, please contact us at telephones: (86-755) 8387 1443, or email: CN_Doccheck@sgs.com

SGS China Inspection & Testing Service (Shanghai) Co., Ltd. 37 Building, No. 889 Yitian Road, Xuhui District, Shanghai, China 200233 TEL (86-21) 61402553 FAX (86-21) 64953679 www.sgs.com.cn
 中国·上海·徐汇区宜山路889号3号楼 邮编: 200233 TEL (86-21) 61402594 FAX (86-21) 61158999 e: sgs.china@sgs.com

Member of the SGS Group (SGS SA)

Test Report

No. SHAEC1718798806

Date: 31 Aug 2017

Page 9 of 23

ATTACHMENTS
Pb/Cd/Hg/Cr⁶⁺/PBBs/PBDEs Testing Flow Chart

- 1) Name of the person who made testing: Meria Jin/Gary Xu/ Rony Chen/Sielina Song
- 2) Name of the person in charge of testing: Jan Shi/Jessy Huang/Luna Xu/Shara Wang
- 3) These samples were dissolved totally by pre-conditioning method according to below flow chart. (Cr⁶⁺ and PBBs/PBDEs test method excluded)

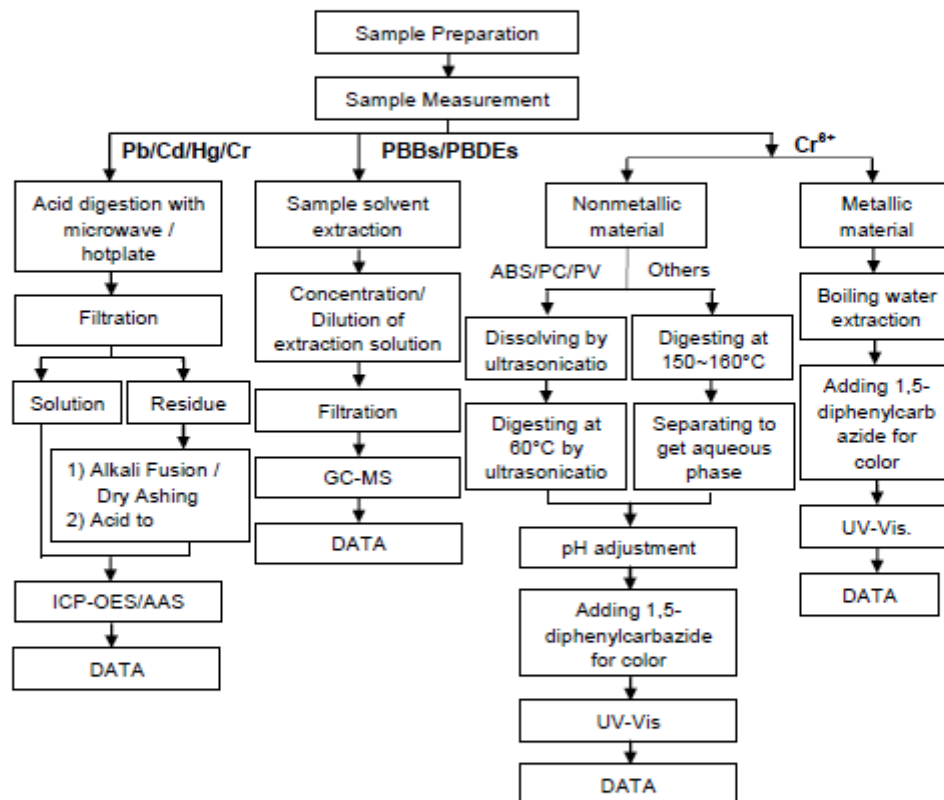

Unless otherwise agreed in writing, this document is issued by the Company subject to its General Conditions of Service printed overleaf, available on request or accessible at http://www.sgs.com/en/Terms-and-Conditions_sgs.asp and, for electronic format documents, subject to Terms and Conditions for Electronic Documents at http://www.sgs.com/en/Terms-and-Conditions/Terms-e-Documents_sgs.asp. Attention is drawn to the limitation of liability, indemnification and jurisdiction issues defined therein. Any holder of this document is advised that information contained hereon reflects the Company's findings at the time of its intervention only and within the limits of Client's instructions, if any. The Company's sole responsibility is to its Client and this document does not exonerate parties to a transaction from exercising all their rights and obligations under the transaction documents. This document cannot be reproduced except in full, without prior written approval of the Company. Any unauthorized alteration, forgery or falsification of the content or appearance of this document is unlawful and offenders may be prosecuted to the fullest extent of the law. Unless otherwise stated the results shown in this test report refer only to the sample(s) tested.

Attention: To check the authenticity of testing inspection report & certificate, please contact us at telephone: (86-755) 8387 1443, or email: CN.Doccheck@sgs.com
 3rd Building, No. 859 Yinan Road, Xuhui District, Shanghai, China 200233 1E&E (86-21) 61402553 1E&E (86-21) 64953079 www.sgs.com
 中国·上海·徐汇区宜山路859号3号楼 邮编: 200233 1HL (86-21) 61402594 1HL (86-21) 61159899 e.sgs.china@sgs.com

Member of the SGS Group (SGS SA)



Test Report

No. SHAEC1718798806

Date: 31 Aug 2017

Page 10 of 23

ATTACHMENTS

Phthalates Testing Flow Chart

- 1) Name of the person who made testing: Sherlock Gao
- 2) Name of the person in charge of testing: Jessy Huang

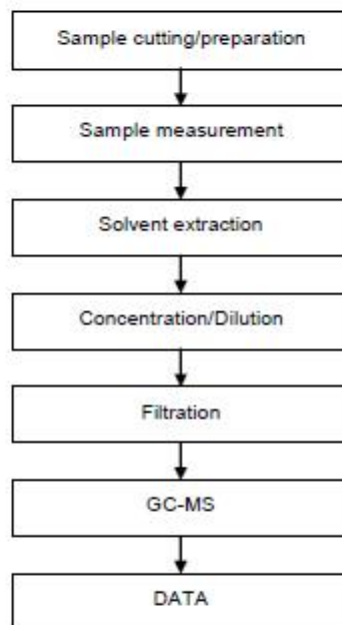

Unless otherwise agreed in writing, this document is issued by the Company subject to its General Conditions of Service printed overleaf, available on request or accessible at <http://www.sgs.com/en/Terms-and-Conditions.aspx> and, for electronic format documents, subject to Terms and Conditions for Electronic Documents at <http://www.sgs.com/en/Terms-and-Conditions/Terms-of-Electronic-Documents.aspx>. Attention is drawn to the limitation of liability, indemnification and jurisdiction issues defined therein. Any holder of this document is advised that information contained hereon reflects the Company's findings at the time of its intervention only and within the limits of Client's instructions, if any. The Company's sole responsibility is to its Client and this document does not exonerate parties to a transaction from exercising all their rights and obligations under the transaction documents. This document cannot be reproduced except in full, without prior written approval of the Company. Any unauthorized alteration, forgery or falsification of the content or appearance of this document is unlawful and offenders may be prosecuted to the fullest extent of the law. Unless otherwise stated the results shown in this test report refer only to the sample(s) tested.

Attention: To check the authenticity of testing/inspection report & certificate, please contact us at telephone: (86-755) 8387 1443, or email: CN.Doccheck@sgs.com

SGS-China (Shanghai) Inspection & Testing Service (P) Co., Ltd.
 13th Building, No. 889 Yishan Road, Xuhui District, Shanghai, China 200233 1E&E (86-21) 61402583 1E&E (86-21) 64953679 www.sgs.com.cn
 中国·上海·徐汇区宜山路889号3号楼 邮编: 200233 1HL (86-21) 61402584 1HL (86-21) 61150898 e: sgs.china@sgs.com

Member of the SGS Group (SGS SA)



Test Report

No. SHAEC1718798806

Date: 31 Aug 2017

Page 11 of 23

ATTACHMENTS

HBCDD Testing Flow Chart

- 1) Name of the person who made testing: Gary Xu
- 2) Name of the person in charge of testing: Jessy Huang

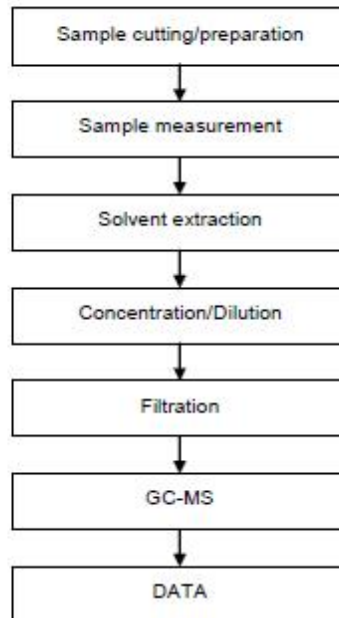

Unless otherwise agreed in writing, this document is issued by the Company subject to its General Conditions of Service printed overleaf, available on request or accessible at <http://www.sgs.com/en/Terms-and-Conditions.aspx> and, for electronic format documents, subject to Terms and Conditions for Electronic Documents at <http://www.sgs.com/en/Terms-and-Conditions/Terms-e-Documents.aspx>. Attention is drawn to the limitation of liability, indemnification and jurisdiction issues defined therein. Any holder of this document is advised that information contained hereon reflects the Company's findings at the time of its intervention only and within the limits of Client's instructions, if any. The Company's sole responsibility is to its Client and this document does not exonerate parties to a transaction from exercising all their rights and obligations under the transaction documents. This document cannot be reproduced except in full, without prior written approval of the Company. Any unauthorized alteration, forgery or falsification of the content or appearance of this document is unlawful and offenders may be prosecuted to the fullest extent of the law. Unless otherwise stated the results shown in this test report refer only to the sample(s) tested.
 Attention: To check the authenticity of testing inspection report & certificate, please contact us at telephone: (86-755) 8987 1643, or email: CN.Doccheck@sgs.com

SGS-CSI (Shanghai) Inspection & Testing Service Co., Ltd. 3rd Building, No. 889 Yinan Road Xuhui District, Shanghai, China 200233 TEL (86-21) 61402553 FAX (86-21) 64953679 www.sgs.com.cn
 Testing Center (Shanghai) 中国·上海·徐汇区宜山路889号3号楼 邮编: 200233 TEL (86-21) 61402554 FAX (86-21) 61158999 e.sgs.china@sgs.com

Member of the SGS Group (SGS SA)



Test Report

No. SHAEC1718798806

Date: 31 Aug 2017

Page 12 of 23

ATTACHMENTS

Halogen Testing (oxygen bomb) Flow Chart

- 1) Name of the person who made testing: Kevin Xu
- 2) Name of the person in charge of testing: Sisily Yin

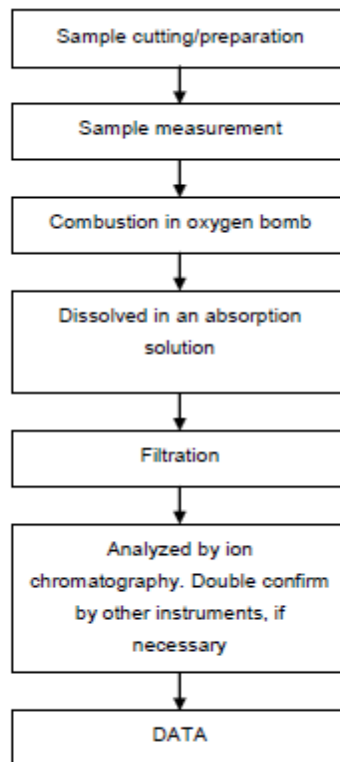

Unless otherwise agreed in writing, this document is issued by the Company subject to its General Conditions of Service printed overleaf, available on request or accessible at http://www.sgs.com/en/Terms-and-Conditions_sgs.asp and, for electronic format documents, subject to Terms and Conditions for electronic documents at http://www.sgs.com/en/Terms-and-Conditions/Terms-e-Documents_sgs.asp. Attention is drawn to the limitation of liability, indemnification and jurisdiction issues defined therein. Any holder of this document is advised that information contained herein reflects the Company's findings at the time of its intervention only and within the limits of Client's instructions, if any. The Company's sole responsibility is to its Client and this document does not exonerate parties to a transaction from exercising all their rights and obligations under the transaction documents. This document cannot be reproduced except in full, without prior written approval of the Company. Any unauthorized alteration, forgery or falsification of the content or appearance of this document is unlawful and offenders may be prosecuted to the fullest extent of the law. Unless otherwise stated the results shown in this test report refer only to the sample(s) tested.
 Attention: To check the authenticity of testing/inspection report & certificate, please contact us at telephone: (86-755) 8387 1443, or email: CN.Doccheck@sgs.com
 SGS-CTI (Shanghai) Inspection & Testing Services Co., Ltd. 3rd Building, No. 889 Yixian Road Xuhui District, Shanghai China 200233 TEL (86-21) 61432553 FAX (86-21) 64853679 www.sgs.com.cn
 中国·上海·徐汇区宜山路889号3号楼 邮编: 200233 TEL (86-21) 61432554 FAX (86-21) 61158899 e sgs.china@sgs.com

Member of the SGS Group (SGS SA)



Test Report

No. SHAEC1718798806

Date: 31 Aug 2017

Page 13 of 23

ATTACHMENTS

PFOA/PFOA Testing Flow Chart

- 1) Name of the person who made testing: Jane Yang
- 2) Name of the person in charge of testing: Myra Ma

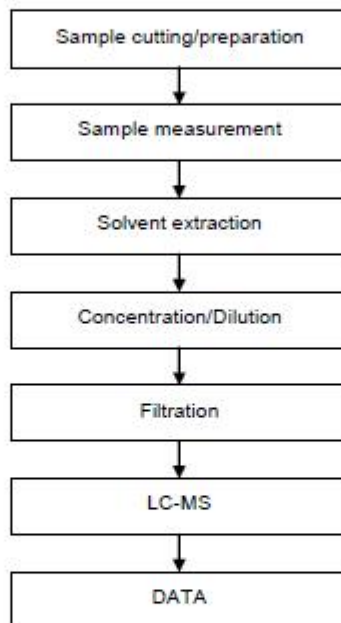

Unless otherwise agreed in writing, this document is issued by the Company subject to its General Conditions of Service printed overleaf, available on request or accessible at <http://www.sgs.com/en/Terms-and-Conditions.sgs> and, for electronic format documents, subject to Terms and Conditions for Electronic Documents at <http://www.sgs.com/en/Terms-and-Conditions/Terms-E-Documents.sgs>. Attention is drawn to the limitation of liability, indemnification and jurisdiction issues defined therein. Any holder of this document is advised that information contained herein reflects the Company's findings at the time of its intervention only and within the limits of Client's instructions, if any. The Company's sole responsibility is to its Client and this document does not exonerate parties to a transaction from exercising all their rights and obligations under the transaction documents. This document cannot be reproduced except in full, without prior written approval of the Company. Any unauthorized alteration, forgery or falsification of the content or appearance of this document is unlawful and offenders may be prosecuted to the fullest extent of the law. Unless otherwise stated the results shown in this test report refer only to the sample(s) tested.

Attention: To check the authenticity of testing inspection report & certificate, please contact us at telephone: (86-755) 8387 1443, or email: CN.Docshcs@sgs.com

3rd Building, No. 836 Yixian Road Xuhui District, Shanghai China 200233 TEL: (86-21) 61432553 FAX: (86-21) 64863679 www.sgs.com.cn
 中国·上海·徐汇区宜山路836号3号楼 邮编: 200233 TEL: (86-21) 61432554 FAX: (86-21) 61150889 e: sgs.china@sgs.com

Member of the SGS Group (SGS SA)



Test Report

No. SHAEC1718798806

Date: 31 Aug 2017

Page 14 of 23

ATTACHMENTS

PVC Testing Flow Chart

- 1) Name of the person who made testing: Jessica Qin
- 2) Name of the person in charge of testing: Linda Li

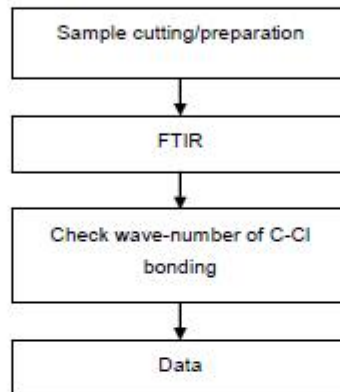

Unless otherwise agreed in writing, this document is issued by the Company subject to its General Conditions of Service printed overleaf, available on request or accessible at <http://www.sgs.com.cn/Terms-and-Conditions.aspx> and, for electronic format documents, subject to Terms and Conditions for Electronic Documents at <http://www.sgs.com.cn/Terms-and-Conditions/Terms-e-Documents.aspx>. Attention is drawn to the limitation of liability, indemnification and jurisdiction issue defined therein. Any holder of this document is advised that information contained herein reflects the Company's findings at the time of its intervention only and within the limits of Client's instructions, if any. The Company's sole responsibility is to its Client and this document does not exonerate parties to a transaction from exercising all their rights and obligations under the transaction documents. This document cannot be reproduced except in full, without prior written approval of the Company. Any unauthorized alteration, forgery or falsification of the content or appearance of this document is unlawful and offenders may be prosecuted to the fullest extent of the law. Unless otherwise stated the results shown in this test report refer only to the sample(s) tested.

Attention: To check the authenticity of testing inspection report & certificate, please contact us at telephone: (86-755) 8167 1443, or e-mail: CH_Documents@sgs.com.cn
 3 Baking No. 859 Yehon Road Xuhui District, Shanghai, China 200233 TEL (86-21) 61402553 FAX (86-21) 64953579 www.sgs.com.cn
 中国·上海·徐汇区宜山路859号3号楼 邮编: 200233 TEL (86-21) 61402554 FAX (86-21) 61198899 e sgs.china@sgs.com

Member of the SGS Group (SGS SA)



Test Report

No. SHAEC1718798806

Date: 31 Aug 2017

Page 15 of 23

ATTACHMENTS

Organotin Testing Flow Chart

- 1) Name of the person who made testing: Alex Deng
- 2) Name of the person in charge of testing: Jessy Huang

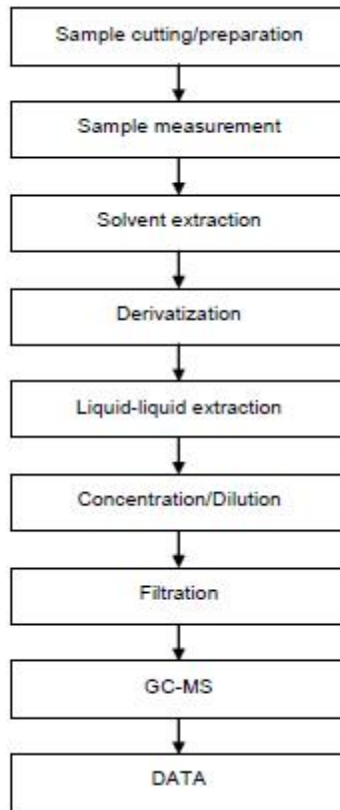

Unless otherwise agreed in writing, this document is issued by the Company subject to its General Conditions of Service printed overleaf, available on request or accessible at <http://www.sgs.com/en/Terms-and-Conditions.aspx> and, for electronic format documents, subject to Terms and Conditions for Electronic Documents at <http://www.sgs.com/en/Terms-and-Conditions.aspx>. Attention is drawn to the limitation of liability, indemnification and jurisdiction issues defined therein. Any holder of this document is advised that information contained herein reflects the Company's findings at the time of its intervention only and within the limits of Client's instructions, if any. The Company's sole responsibility is to its Client and this document does not exonerate parties to a transaction from exercising all their rights and obligations under the transaction documents. This document cannot be reproduced except in full, without prior written approval of the Company. Any unauthorized alteration, forgery or falsification of the content or appearance of this document is unlawful and offenders may be prosecuted to the fullest extent of the law. Unless otherwise stated the results shown in this test report refer only to the sample(s) tested.

Attention: To check the authenticity of testing (inspection report & certificate), please contact us at telephone: (86-755) 9387 1443, or email: CN.Qincheck@sgs.com

3rd Building, No. 859 Yixian Road, Xuhui District, Shanghai, China 200233 | TEL (86-21) 61402583 | FAX (86-21) 64953579 | www.sgs.com.cn
 中国·上海·徐汇区宜山路859号3号楼 邮编: 200233 | TEL (86-21) 61402584 | FAX (86-21) 61159899 | e.sgs.china@sgs.com

Member of the SGS Group (SGS SA)



Test Report

No. SHAEC1718798806

Date: 31 Aug 2017

Page 16 of 23

ATTACHMENTS

PCB/ PCT/ PCN Testing Flow Chart

- 1) Name of the person who made testing: Jenny Zhang
- 2) Name of the person in charge of testing: Ziroo Yu

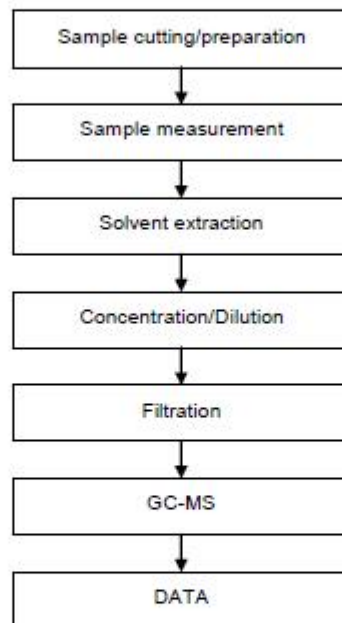

Unless otherwise agreed in writing, this document is issued by the Company subject to its General Conditions of Service printed overleaf, available on request or accessible at <http://www.sgs.com/en/Terms-and-Conditions.aspx> and, for electronic format documents, subject to Terms and Conditions for Electronic Documents at <http://www.sgs.com/en/Terms-and-Conditions/Terms-e-Documents.aspx>. Attention is drawn to the limitation of liability, indemnification and jurisdiction issues defined therein. Any holder of this document is advised that information contained hereon reflects the Company's findings at the time of its intervention only and within the limits of Client's instructions, if any. The Company's sole responsibility is to its Client and this document does not exonerate parties to a transaction from exercising all their rights and obligations under the transaction documents. This document cannot be reproduced except in full, without prior written approval of the Company. Any unauthorized alteration, forgery or falsification of the content or appearance of this document is unlawful and offenders may be prosecuted to the fullest extent of the law. Unless otherwise stated the results shown in this test report refer only to the sample(s) tested.

Attention: To check the authenticity of testing inspection report & certificate, please contact us at telephone: (86-755) 8387 1443, or email: CN.doccheck@sgs.com
 13 Building, No. 889 Yancheng Road, Xuhui District, Shanghai, China 200233 1 E&E (86-21) 61402553 1 E&E (86-21) 64953679 www.sgs.com.cn
 中国·上海·徐汇区宜山路889号3号楼 邮编: 200233 1 HL (86-21) 61432594 1 HL (86-21) 61150899 e sgs.china@sgs.com

Member of the SGS Group (SGS SA)



Test Report

No. SHAEC1718798806

Date: 31 Aug 2017

Page 17 of 23

ATTACHMENTS

SCCP/MCCP Testing Flow Chart

- 1) Name of the person who made testing: Jenny Zhang
- 2) Name of the person in charge of testing: Ziruo Yu

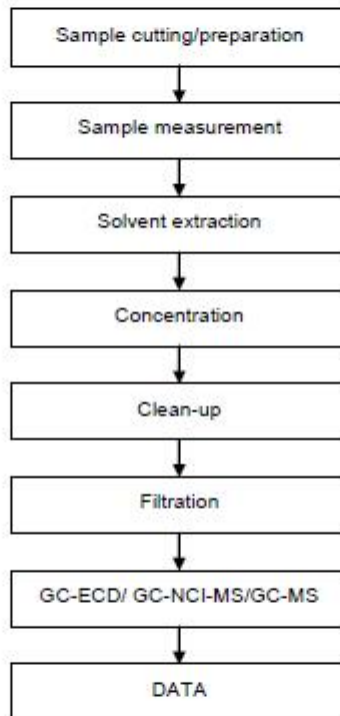

Unless otherwise agreed in writing, this document is issued by the Company subject to its General Conditions of Service printed overleaf, available on request or accessible at <http://www.sgs.com/en/Terms-and-Conditions.aspx> and, for electronic format documents, subject to Terms and Conditions for Electronic Documents at <http://www.sgs.com/en/Terms-and-Conditions/Terms-e-Documents.aspx>. Attention is drawn to the limitation of liability, indemnification and jurisdiction issues defined therein. Any holder of this document is advised that information contained herein reflects the Company's findings at the time of its intervention only and within the limits of Client's instructions, if any. The Company's sole responsibility is to its Client and this document does not exonerate parties to a transaction from exercising all their rights and obligations under the transaction documents. This document cannot be reproduced except in full, without prior written approval of the Company. Any unauthorized alteration, forgery or falsification of the content or appearance of this document is unlawful and offenders may be prosecuted to the fullest extent of the law. Unless otherwise stated the results shown in this test report refer only to the sample(s) tested.

Attention: To check the authenticity of testing/inspection report & certificate, please contact us at telephone: (86-755) 8387 1443, or email: CN_Gocheck@sgs.com

3rd Building, No. 859 Yixian Road Xuhui District, Shanghai China 200233 1E&E (86-21) 61402583 1E&E (86-21) 64863679 www.sgs.com.cn
 中国·上海·徐汇区宜山路859号3号楼 邮编: 200233 1HL (86-21) 61432584 1HL (86-21) 61158899 e sgs.china@sgs.com

Member of the SGS Group (SGS SA)



Test Report

No. SHAEC1718798806

Date: 31 Aug 2017

Page 18 of 23

ATTACHMENTS

Elements Testing Flow Chart

- 1) Name of the person who made testing: Meria Jin/Sielina Song
- 2) Name of the person in charge of testing: Luna Xu/Jan Shi

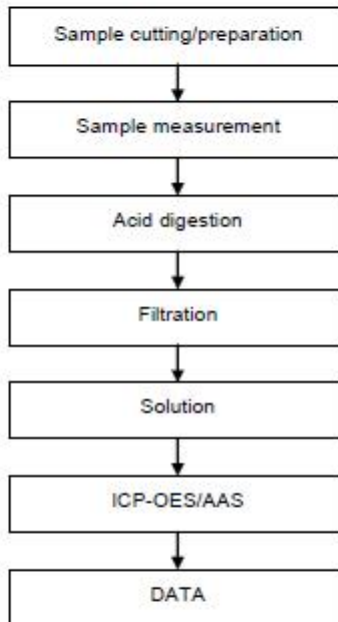

Unless otherwise agreed in writing, this document is issued by the Company subject to its General Conditions of Service printed overleaf, available on request or accessible at <http://www.sgs.com/en/Terms-and-Conditions.aspx> and, for electronic format documents, subject to Terms and Conditions for Electronic Documents at <http://www.sgs.com/en/Terms-and-Conditions/Terms-e-Document.aspx>. Attention is drawn to the limitation of liability, indemnification and jurisdiction issues defined therein. Any holder of this document is advised that information contained herein reflects the Company's findings at the time of its intervention only and within the limits of Client's instructions, if any. The Company's sole responsibility is to its Client and this document does not exonerate parties to a transaction from exercising all their rights and obligations under the transaction documents. This document cannot be reproduced except in full, without prior written approval of the Company. Any unauthorized alteration, forgery or falsification of the content or appearance of this document is unlawful and offenders may be prosecuted to the fullest extent of the law. Unless otherwise stated the results shown in this test report refer only to the sample(s) tested.

Attention: To check the authenticity of testing inspection report & certificate, please contact us at telephones: (86-755) 8367 1443, or email: CN_Doccheck@sgs.com
 3rd Building, No. 886 Yixian Road Xuhui District, Shanghai China 200233 1EAE (86-21) 61402553 1EAE (86-21) 64953679 www.sgs.com.cn
 中国·上海·徐汇区宜山路886号3号楼 邮编: 200233 1HL (86-21) 61402594 1HL (86-21) 61150899 sgs.china@sgs.com

Member of the SGS Group (SGS SA)

Test Report

No. SHAEC1718798806

Date: 31 Aug 2017

Page 19 of 23

ATTACHMENTS
Red Phosphorus Testing Flow Chart

- 1) Name of the person who made testing: Jessica Qin / Zhengyong Rao
- 2) Name of the person in charge of testing: Linda Li/Summer Jin

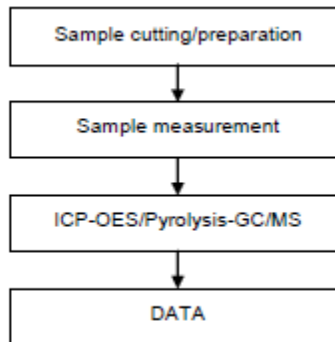

Unless otherwise agreed in writing, this document is issued by the Company subject to its General Conditions of Service printed overleaf, available on request or accessible at <http://www.sgs.com/en/Terms-and-Conditions.aspx> and, for electronic format documents, subject to Terms and Conditions for Electronic Documents at <http://www.sgs.com/en/Terms-and-Conditions/Terms-e-Documents.aspx>. Attention is drawn to the limitation of liability, indemnification and jurisdiction issues defined therein. Any holder of this document is advised that information contained hereon reflects the Company's findings at the time of its intervention only and within the limits of Client's instructions, if any. The Company's sole responsibility is to its Client and this document does not exonerate parties to a transaction from exercising all their rights and obligations under the transaction documents. This document cannot be reproduced except in full, without prior written approval of the Company. Any unauthorized alteration, forgery or falsification of the content or appearance of this document is unlawful and offenders may be prosecuted to the fullest extent of the law. Unless otherwise stated the results shown in this test report refer only to the sample(s) tested.

Attention: To check the authenticity of testing (inspection report & certificate, please contact us at telephone: (86-755)83871443, or email: CN.Doccheck@sgs.com

3rd Building, No. 889 Yitian Road Xuhui District, Shanghai China 200233 1EAE (86-21) 61402553 1EAE (86-21) 64863679 www.sgs.com
 中国·上海·徐汇区宜山路889号3号楼 邮编: 200233 1HL (86-21) 61402594 1HL (86-21) 61150899 e sgs.china@sgs.com

Member of the SGS Group (SGS SA)



Test Report

No. SHAEC1718798806

Date: 31 Aug 2017

Page 20 of 23

ATTACHMENTS

TBBP-A Testing Flow Chart

- 1) Name of the person who made testing: Gary Xu
- 2) Name of the person in charge of testing: Jessy Huang

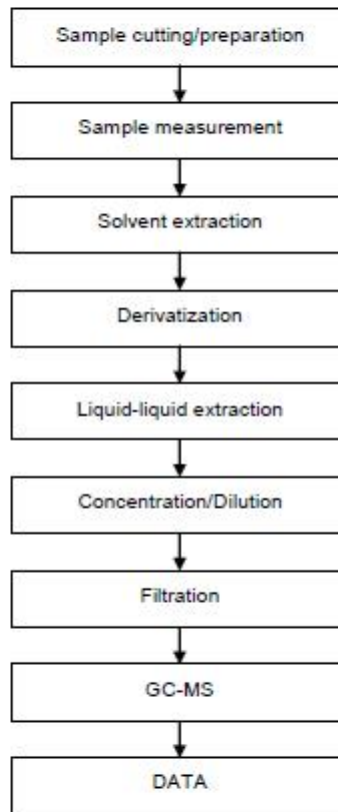

Unless otherwise agreed in writing, this document is issued by the Company subject to its General Conditions of Service printed overleaf, available on request or accessible at <http://www.sgs.com/en/Terms-and-Conditions.aspx> and, for electronic format documents, subject to Terms and Conditions for Electronic Documents at <http://www.sgs.com/en/Terms-and-Conditions/Terms-e-Documents.aspx>. Attention is drawn to the limitation of liability, indemnification and jurisdiction issues defined therein. Any holder of this document is advised that information contained hereon reflects the Company's findings at the time of its intervention only and within the limits of Client's instructions, if any. The Company's sole responsibility is to its Client and this document does not exonerate parties to a transaction from exercising all their rights and obligations under the transaction documents. This document cannot be reproduced except in full, without prior written approval of the Company. Any unauthorized alteration, forgery or falsification of the content or appearance of this document is unlawful and offenders may be prosecuted to the fullest extent of the law. Unless otherwise stated the results shown in this test report refer only to the sample(s) tested.

Attention: To check the authenticity of testing inspection report & certificate, please contact us at telephone: (86-755) 8367 1643, or email: CR.Doccheck@sgs.com
 3rd Building, No. 839 Yifan Road, Xuhui District, Shanghai, China 200233 1E&E (86-21) 61402553 1E&E (86-21) 64953579 www.sgs.com.cn
 中国·上海·徐汇区宜山路839号3号楼 邮编: 200233 1HL (86-21) 01402584 1HL (86-21) 01109999 e sgs.china@sgs.com

Member of the SGS Group (SGS SA)



Test Report

No. SHAEC1718798806

Date: 31 Aug 2017

Page 21 of 23

ATTACHMENTS

BPA Testing Flow Chart

- 1) Name of the person who made testing: Alfred Chen
- 2) Name of the person in charge of testing: Judy Li

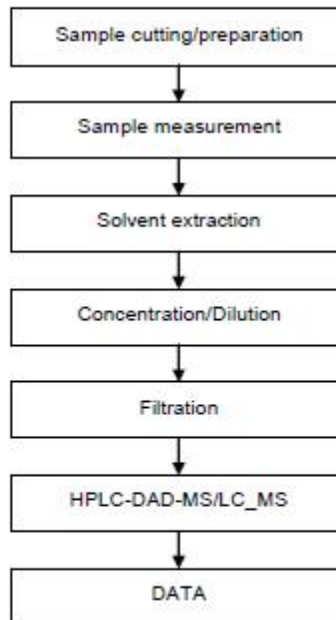

Unless otherwise agreed in writing, this document is issued by the Company subject to its General Conditions of Service printed overleaf, available on request or accessible at <http://www.sgs.com/en/Terms-and-Conditions.aspx> and, for electronic format documents, subject to Terms and Conditions for Electronic Documents at <http://www.sgs.com/en/Terms-and-Conditions/Terms-e-Documents.aspx>. Attention is drawn to the limitation of liability, indemnification and jurisdiction issues defined therein. Any holder of this document is advised that information contained hereon reflects the Company's findings at the time of its intervention only and within the limits of Client's instructions, if any. The Company's sole responsibility is to its Client and this document does not exonerate parties to a transaction from exercising all their rights and obligations under the transaction documents. This document cannot be reproduced except in full, without prior written approval of the Company. Any unauthorized alteration, forgery or falsification of the content or appearance of this document is unlawful and offenders may be prosecuted to the fullest extent of the law. Unless otherwise stated the results shown in this test report refer only to the sample(s) tested.

Attention: To check the authenticity of testing/inspection report & certificate, please contact us at telephone: (86-755) 8367 1443, or email: CN.Doccheck@sgs.com

3rd Building, No. 839 Yahan Road Xuhui District, Shanghai China 200233 1E&E (86-21) 61402583 1E&E (86-21) 64953679 www.sgs.com.cn
 中国·上海·徐汇区宜山路839号3号楼 邮编: 200233 1HL (86-21) 61402584 1HL (86-21) 61150999 e sgs.china@sgs.com

Member of the SGS Group (SGS SA)



Test Report

No. SHAEC1718798806

Date: 31 Aug 2017

Page 22 of 23

ATTACHMENTS

DMF (Dimethyl fumarate) Testing Flow Chart

- 1) Name of the person who made testing: Alex Deng
- 2) Name of the person in charge of testing: Jessy Huang

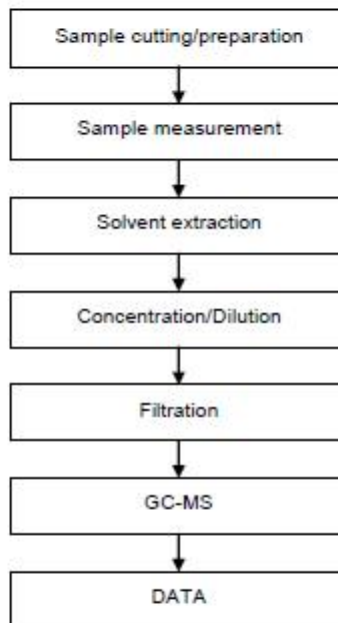

Unless otherwise agreed in writing, this document is issued by the Company subject to its General Conditions of Service printed overleaf, available on request or accessible at <http://www.sgs.com/en/Terms-and-Conditions.aspx> and, for electronic format documents, subject to Terms and Conditions for Electronic Documents at <http://www.sgs.com/en/Terms-and-Conditions/Terms-e-Documents.aspx>. Attention is drawn to the limitation of liability, indemnification and jurisdiction issues defined therein. Any holder of this document is advised that information contained hereon reflects the Company's findings at the time of its intervention only and within the limits of Client's instructions, if any. The Company's sole responsibility is to its Client and this document does not exonerate parties to a transaction from exercising all their rights and obligations under the transaction documents. This document cannot be reproduced except in full, without prior written approval of the Company. Any unauthorized alteration, forgery or falsification of the content or appearance of this document is unlawful and offenders may be prosecuted to the fullest extent of the law. Unless otherwise stated the results shown in this test report refer only to the sample(s) tested.

Attention: To check the authenticity of testing/inspection report & certificate, please contact us at telephone: (86-755) 8387 1443, or email: CN.Doccheck@sgs.com

3rd Building, No. 889 Yehen Road Xuhui District, Shanghai China 200233 1E&E (86-21) 61402553 1E&E (86-21) 64853679 www.sgs.com.cn
 中国·上海·徐汇区宜山路889号3号楼 邮编: 200233 1HL (86-21) 61432584 1HL (86-21) 61150899 e.sgs.china@sgs.com

Member of the SGS Group (SGS SA)



Test Report

No. SHAEC1718798806

Date: 31 Aug 2017

Page 23 of 23

Sample photo:



SGS authenticates the photo on original report only

*** End of Report ***



Unless otherwise agreed in writing, this document is issued by the Company subject to its General Conditions of Service printed overleaf, available on request or accessible at <http://www.sgs.com/en/terms-and-conditions.aspx> and, for electronic format documents, subject to Terms and Conditions for Electronic Documents at <http://www.sgs.com/en/terms-and-conditions/terms-e-document.aspx>. Attention is drawn to the limitation of liability, indemnification and jurisdiction clauses defined therein. Any holder of this document is advised that information contained hereon reflects the Company's findings at the time of its intervention only and within the limits of Client's instructions, if any. The Company's sole responsibility is to its Client and this document does not exonerate parties to a transaction from exercising all their rights and obligations under the transaction documents. This document cannot be reproduced, except in full, without prior written approval of the Company. Any unauthorized alteration, forgery or falsification of the content or appearance of this document is unlawful and offenders may be prosecuted to the fullest extent of the law. Unless otherwise stated the results shown in this test report refer only to the sample(s) tested.
 Attention: To check the authenticity of testing/inspection report & certificate, please contact us at telephone: (86-755) 8367 1443, or email: CN.Doccheck@sgs.com

3rd Building, No. 839 Yitian Road, Xuhui District, Shanghai, China 200233 1E&E (86-21) 61402553 1E&E (86-21) 64653679 www.sgs.com
 中国·上海·徐汇区宜山路889号3号楼 邮编: 200233 1HL (86-21) 61402584 1HL (86-21) 61150899 e sgs.china@sgs.com

Member of the SGS Group (SGS SA)