



BTC1510F3

NPN SILICON TRANSISTOR

NPN EPITAXIAL PLANAR TRANSISTOR

■ DESCRIPTION

As a NPN Darlington transistor the UTC **BTC1510F3** is designed for general purpose amplifier and low speed switching application.

■ FEATURES

- * Very high BV_{CEO}
- * Very low $V_{CE(SAT)}$
- * Very high current gain

■ EQUIVALENT CIRCUIT

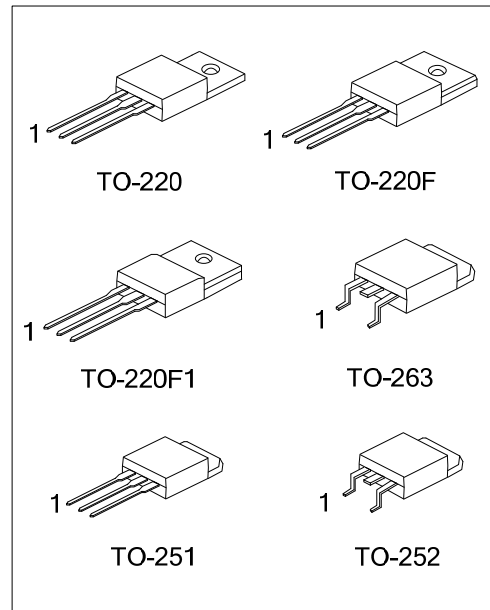
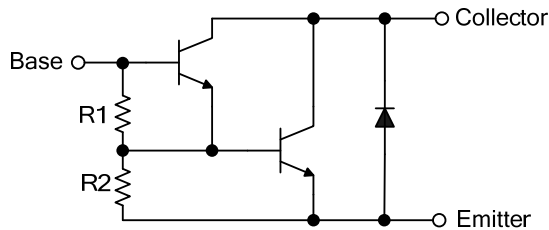

■ ORDERING INFORMATION

Ordering Number		Package	Pin Assignment			Packing
Lead Free	Halogen Free		1	2	3	
BTC1510F3L-TA3-T	BTC1510F3G-TA3-T	TO-220	B	C	E	Tube
BTC1510F3L-TF3-T	BTC1510F3G-TF3-T	TO-220F	B	C	E	Tube
BTC1510F3L-TF1-T	BTC1510F3G-TF1-T	TO-220F1	B	C	E	Tube
BTC1510F3L-TM3-T	BTC1510F3G-TM3-T	TO-251	B	C	E	Tube
BTC1510F3L-TN3-R	BTC1510F3G-TN3-R	TO-252	B	C	E	Tape Reel
BTC1510F3L-TQ2-T	BTC1510F3G-TQ2-T	TO-263	B	C	E	Tube
BTC1510F3L-TQ2-R	BTC1510F3G-TQ2-R	TO-263	B	C	E	Tape Reel

Note: Pin Assignment: B: Base C: Collector E: Emitter

<p>BTC1510F3G-TA3-T</p> <p>(1)Packing Type</p> <p>(2)Package Type</p> <p>(3)Green Package</p>	<p>(1) T: Tube, R: Tape Reel</p> <p>(2) TA3: TO-220, TF3: TO-220F, TF1: TO-220F1</p> <p>TM3: TO-251, N3: TO-252, TQ2: TO-263</p> <p>(3) G: Halogen Free and Lead Free, L: Lead Free</p>
---	---

■ MARKING

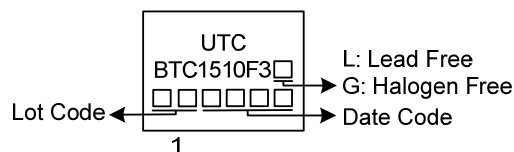

BTC1510F3

NPN SILICON TRANSISTOR

■ ABSOLUTE MAXIMUM RATING ($T_A=25^{\circ}\text{C}$, unless otherwise specified)

PARAMETER		SYMBOL	RATINGS	UNIT
Collector-Base Voltage		V_{CB0}	150	V
Collector-Emitter Voltage		V_{CEO}	150	V
Emitter-Base Voltage		V_{EBO}	5	V
Collector Current	DC	I_C	10	A
	Pulse(Note 2)		15	
Collector Dissipation	$T_A=25^{\circ}\text{C}$	TO-220/TO-220F TO-220F1	2	W
		TO-251/TO-252	1.1	W
		TO-263	2	W
	$T_C=25^{\circ}\text{C}$	TO-220	72	W
		TO-220F/TO-220F1	36	W
		TO-251/TO-252	44	W
		TO-263	60	W
Junction Temperature		T_J	150	$^{\circ}\text{C}$
Storage Temperature		T_{STG}	-55 ~ +150	$^{\circ}\text{C}$

Notes: 1. Absolute maximum ratings are those values beyond which the device could be permanently damaged.

Absolute maximum ratings are stress ratings only and functional device operation is not implied.

2. Pulse test: Pulse Width=100ms

■ ELECTRICAL CHARACTERISTICS

PARAMETER	SYMBOL	TEST CONDITIONS	MIN	TYP	MAX	UNIT
Collector-Base Breakdown Voltage	BV_{CB0}	$I_C=100\mu\text{A}$, $I_E=0$	150			V
Collector-Emitter Breakdown Voltage	BV_{CEO}	$I_C=5\text{mA}$, $I_B=0$	150			V
Base-Emitter Turn-On Voltage (Note)	$V_{BE(ON)}$	$V_{CE}=3\text{V}$, $I_C=5\text{A}$			2.8	V
		$V_{CE}=3\text{V}$, $I_C=10\text{A}$			4.5	V
Forward Voltage	V_{FEC}	$I_C=5\text{A}$			3	V
Collector Cutoff Current	I_{CB0}	$V_{CB}=150\text{V}$, $I_E=0$			200	μA
Collector Cutoff Current	I_{CEO}	$V_{CE}=150\text{V}$, $I_E=0$			200	μA
Emitter Cutoff Current	I_{EBO}	$V_{EB}=5\text{V}$, $I_C=0$			2	mA

ON CHARACTERISTICS

DC Current Gain (Note)	h_{FE}	$V_{CE}=3\text{V}$, $I_C=5\text{A}$	2		20	K
		$V_{CE}=3\text{V}$, $I_C=10\text{A}$	100			
Base-Emitter Saturation Voltage(Note)	$V_{BE(SAT)}$	$I_C=5\text{A}$, $I_B=5\text{mA}$			2	V
Collector-Emitter Saturation Voltage (Note)	$V_{CE(SAT)}$	$I_C=5\text{A}$, $I_B=10\text{mA}$			1.5	V
		$I_C=10\text{A}$, $I_B=100\text{mA}$			3	V
		$I_C=5\text{A}$, $I_B=2.5\text{mA}$			2	V

Note: Pulse test: Pulse Width $\leq 380\mu\text{s}$, Duty Cycle $\leq 2\%$

■ TYPICAL CHARACTERISTICS

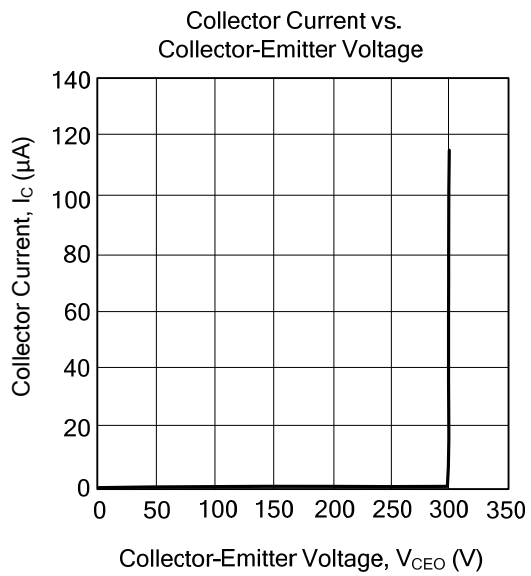
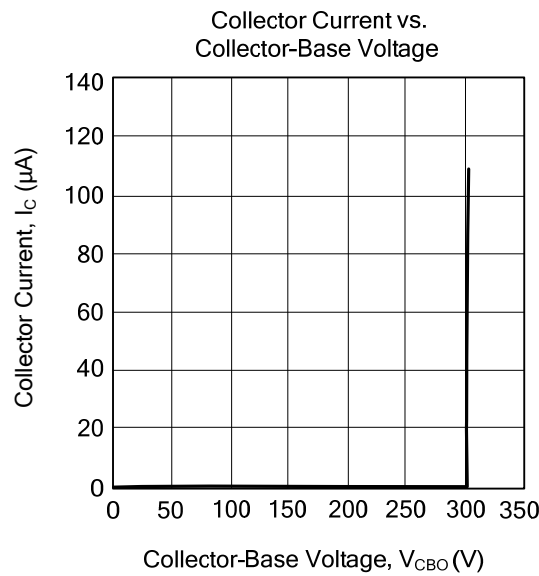

UTC assumes no responsibility for equipment failures that result from using products at values that exceed, even momentarily, rated values (such as maximum ratings, operating condition ranges, or other parameters) listed in products specifications of any and all UTC products described or contained herein. UTC products are not designed for use in life support appliances, devices or systems where malfunction of these products can be reasonably expected to result in personal injury. Reproduction in whole or in part is prohibited without the prior written consent of the copyright owner. UTC reserves the right to make changes to information published in this document, including without limitation specifications and product descriptions, at any time and without notice. This document supersedes and replaces all information supplied prior to the publication hereof.