



DEQING HUAYING ELECTRONICS CO.,LTD.

# APPROVAL SHEET

## SAW BANDPASS FILTER PART NO.: NDFH011-1960SA

<b>Product Type:</b>		<b>Customer:</b>	
SAW Filter			
<b>Part NO.:</b>		<b>Customer Part NO.:</b>	
NDFH011-1960SA			
<b>Ver. Ctrl.:</b>		<b>Issued Date:</b>	
SFH011-1960SA -181115-v1.2			

PREPARED BY	CHECKED BY	APPROVED BY

Part No.	:	NDFH011-1960SA
Pages	:	8
Data	:	2018-11-15
Revision	:	SFH011-1960SA -181115-v1.2

Add (Deqing): 188 Zhiyuan North Rd.Wukang Town Deqing County Zhejiang Province 313200,P.R.China  
Phone : +86-572-8281127  
Fax : +86-572-8281298  
E-mail : [sales@dquaying.com](mailto:sales@dquaying.com)  
Website : <http://www.dquaying.com>



**Features**

SAW filter for LTE BAND 2 (Rx).

- 1 High stability and reliability with good performance and no adjustment.
- 2 Single ended to Single ended.
- 3 Narrow and sharp pass band characteristics. RoHS compatible.
- 4 Low insertion loss and deep stop band attenuation for interference.
- 5 Useable Pass band 60MHz.
- 6 Package size 1.1mm\*0.9mm

**Package Dimensions**

Ceramic Package: Unit: mm

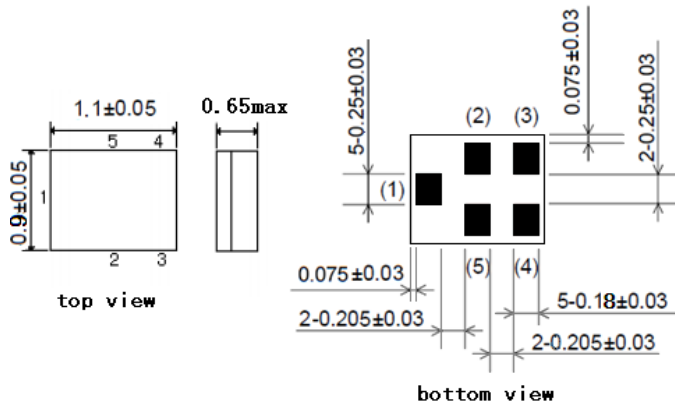

**Pin Configuration**

1	Input
4	Output
2,3,5	Ground

**Marking**

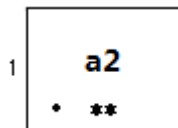

Top View, Laser Marking

"a2" Part number

"." Dot marking, indicates input 1

"1" Terminal1

The first "\*": Month Code (The code shown below varies in a 4-year-cycle)

Month	1	2	3	4	5	6	7	8	9	10	11	12
2016/2020	n	p	q	r	s	t	u	v	w	x	y	z
2017/2021	A	B	C	D	E	F	G	H	J	K	L	M
2018/2022	N	P	Q	R	S	T	U	V	W	X	Y	Z
2019/2023	a	b	c	d	e	f	g	h	i	j	k	m

The second "\*": Date Code

data	1st	2nd	3rd	4th	5th	6th	7th	8th	9th	10th	
code	A	B	C	D	E	F	G	H	J	K	
data	11th	12th	13th	14th	15th	16th	17th	18th	19th	20th	
code	L	M	N	P	Q	R	S	T	U	V	
data	21st	22nd	23rd	24th	25th	26th	27th	28th	29th	30th	31st
code	W	X	Y	Z	a	b	d	e	f	g	h

## Maximum Ratings

Rating		Value	Unit
DC Voltage (between any Terminals)	$V_{DC}$	10	V
RF Power (in <i>BW</i> )	$P$	13 dBm /2000hr@55°C	
Operating Temperature Range	$T_A$	-30 ~ +85	°C
Storage Temperature Range	$T_{stg}$	-40 ~ +85	°C
ESD Voltage (HB)	$V_{ESD}$	>150	V
Moisture Sensitivity Levels	$MSL$	2A	

## Electrical Characteristics:

Item		Minimum	Typical	Maximum	Unit	
Insertion Loss	$IL$					
		1932.4 ...1987.6 MHz		1.5	2.2	dB
		1930.0 ...1990.0 MHz		1.7	2.5	
Passband Ripple	$Pr$					
		1930.0 ...1990.0 MHz		0.9	2.0	dB
VSWR	$V_{swr}$					
		1930.0 ...1990.0 MHz		1.5	2.1	
Absolute Attenuation	$\alpha$					
		30 .... 824 MHz	31	34	dB	
		824 .... 849 MHz	31	34	dB	
		849 .... 1850 MHz	26	30	dB	
		1852.4 .... 1907.6 MHz	35	46	dB	
		2065.... 2150 MHz	25	28	dB	
		2150 .... 2400 MHz	25	28	dB	
		2400 .... 2500 MHz	33	38	dB	
2500 .... 8000 MHz	25	28	dB			
Input / Output Impedance (Nominal)		50			$\Omega$	

 RoHS Compliant

 Electrostatic Sensitive Device

## Test Circuit

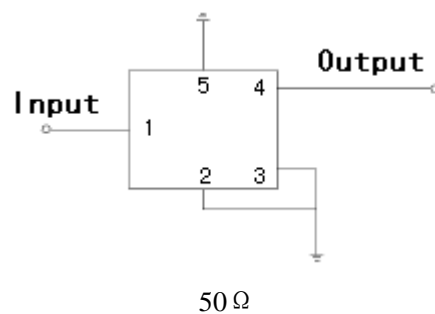

Typical Frequency Response

S21

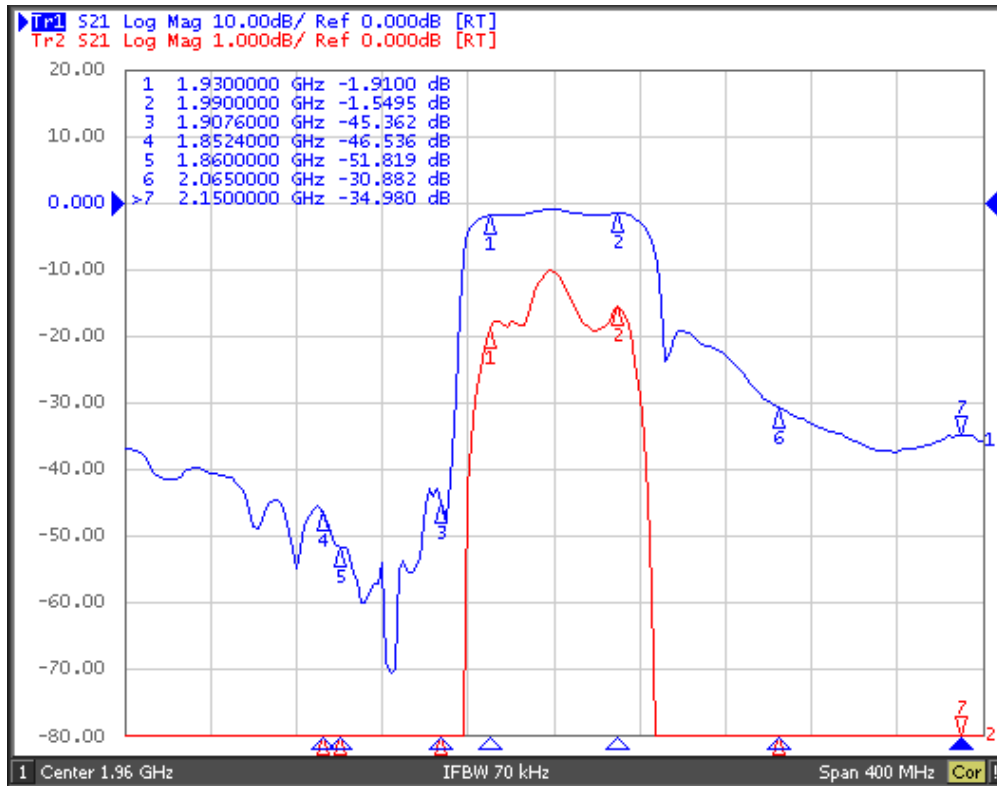

S11

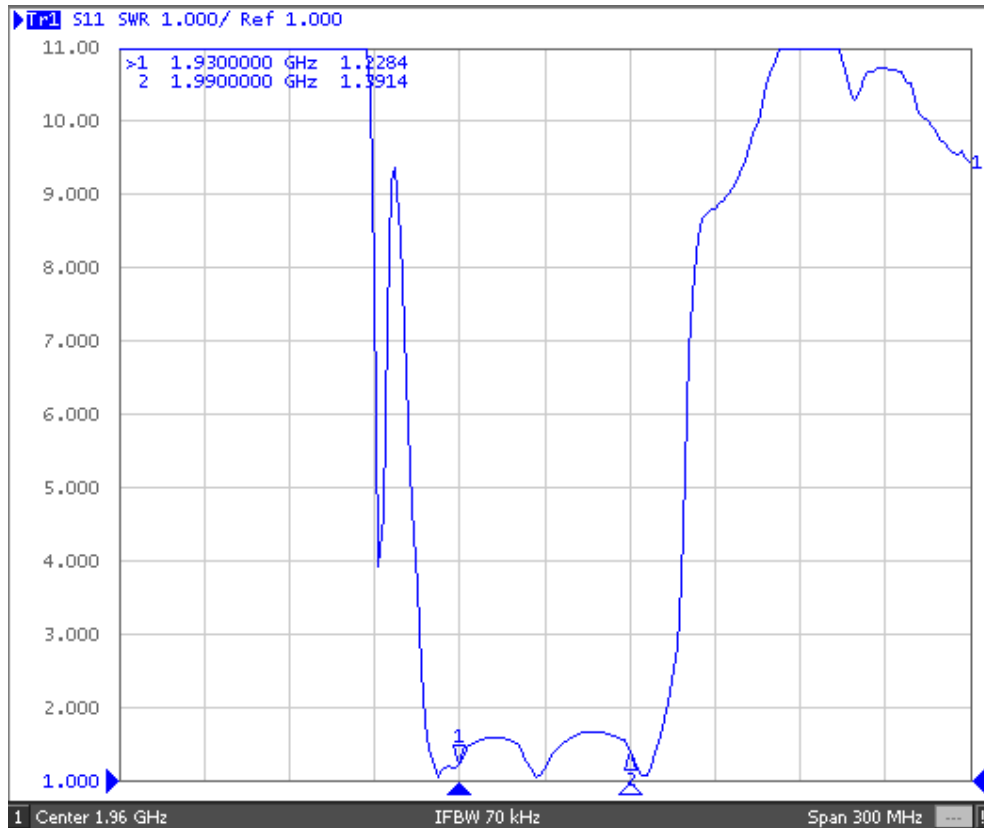

S22

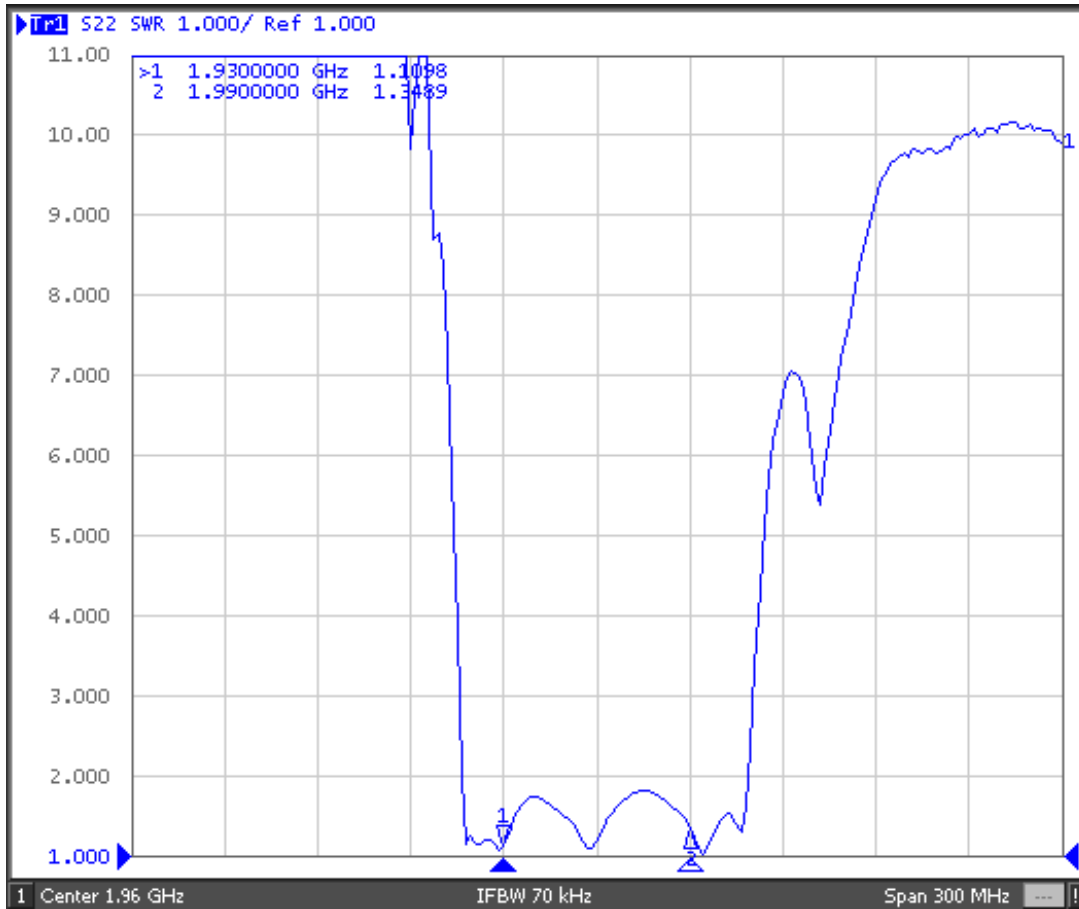

Far side

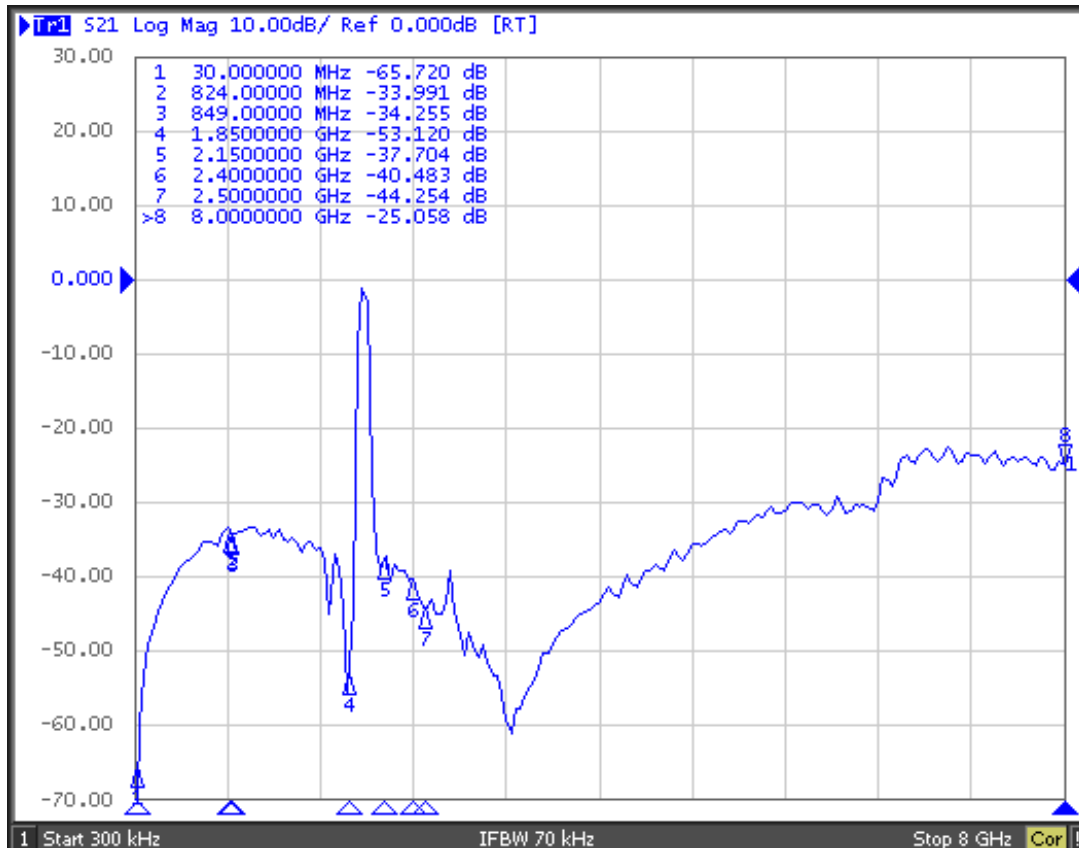

**Stability Characteristics**

Item No.	Test Item	STD Reference	Test Conditions	per lot
	Preconditioning	JESD22-A113	1) Temperature Cycling, 5 cycles -40°C to 85°C; 2) Bake, 24 hrs @85±5°C; 3)Moisture Soak, Soak time and conditions per IPC/JEDEC J-STD-020 based on device MSL level; 4) Reflow, 3 reflow cycles; 5) Drying, Room ambient temperature.	All behind
1	Temperature Cycling	JESD22-A104	-40°C / +85°C,5°C/min,15min dwell,<1 min transfer time,500cycles	3*25 pcs
2	High Temperature Storage	JESD22-A103	Temperature=85°C, 1000 hours.	3*25 pcs
3	Temperature Humidity no bias	JEDEC Std A101-B	85°C 85%RH 240 hours	3*25 pcs
4	Human Body Mode ESD	JESD22-A114	Ta=25°C, ≥100V	3 pcs
5	Charge Device Mode ESD	JESD22-C101	Ta=25°C, ≥100V	3 pcs
6	Solderability	JESD22-B102	Wetting: 245°C, 5s.	22 pcs
7	Drop Test	JESD22-B111	1500 Gs, 0.5 millisecond duration, half-sine pulse.	20 pcs
8	Mechanical Shock	JESD-47	Shock pulse of 1500g with pulse duration of 0.5+/-0.1msec (X ,Y & Z); 5 shocks per axis.	3*25 pcs

**Requirements:** The SAW filer shall remain within the electrical specifications after tests.

**Remarks**

- SAW devices should not be used in any type of fluid such as water, oil, organic solvent, etc.
- Be certain not to apply voltage exceeding the rated voltage of components.
- Do not operate outside the recommended operating temperature range of components.
- Sudden change of temperature shall be avoided, deterioration of the characteristics can occur.
- Be careful of soldering temperature and duration of components when soldering.
- Do not place soldering iron on the body of components.
- Be careful not to subject the terminals or leads of components to excessive force.
- SAW devices are electrostatic sensitive. Please avoid static voltage during operation and storage.
- Ultrasonic cleaning shall be avoided. Ultrasonic vibration may cause destruction of components.

**Packing Information**

Carrier Tape

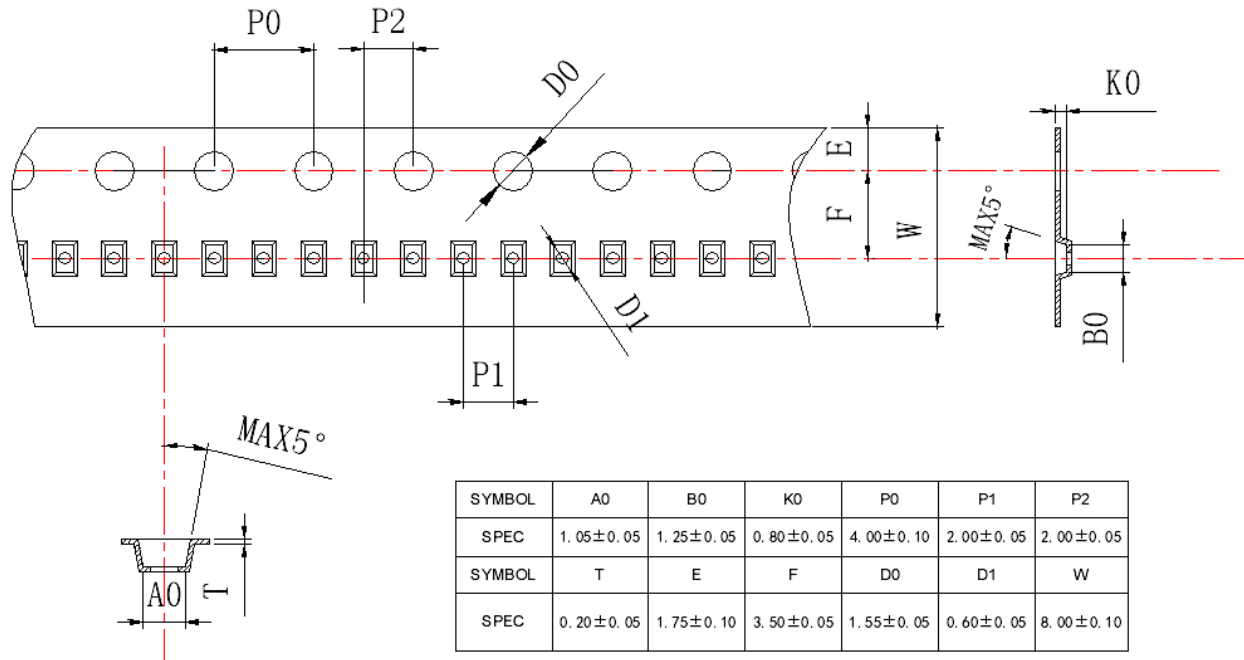

Reel Dimensions

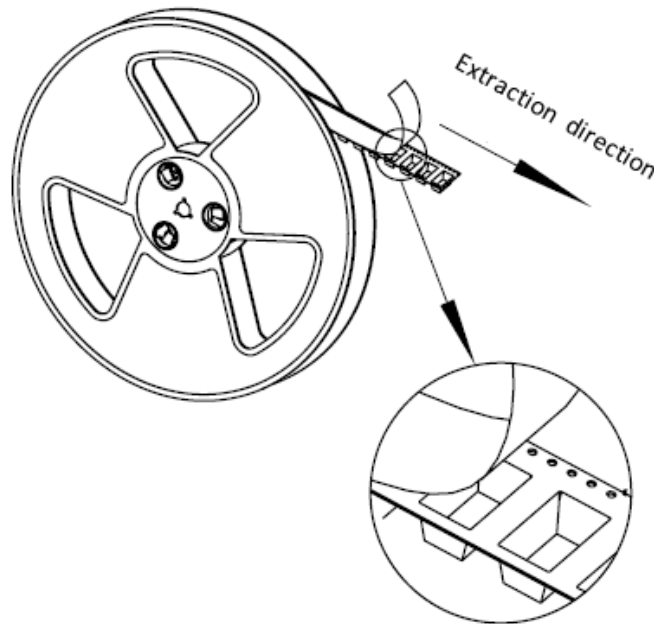

Material	PS
Unit	mm
Tolerance	±0.20mm
Quantity	10000/reel

Outer Packing

Type	Quantity	Dimension	Description	Weight
Carton Box I	100000	240x210x285	anti-static plastic bag & carton box 1 reel / bag	2.15
Carton Box II	300000	470x310x285	10bags / box (100000 pcs) 30 bags / box (300000pcs)	6.22

Unit: mm

Unit: kg



## Recommended Soldering Profile

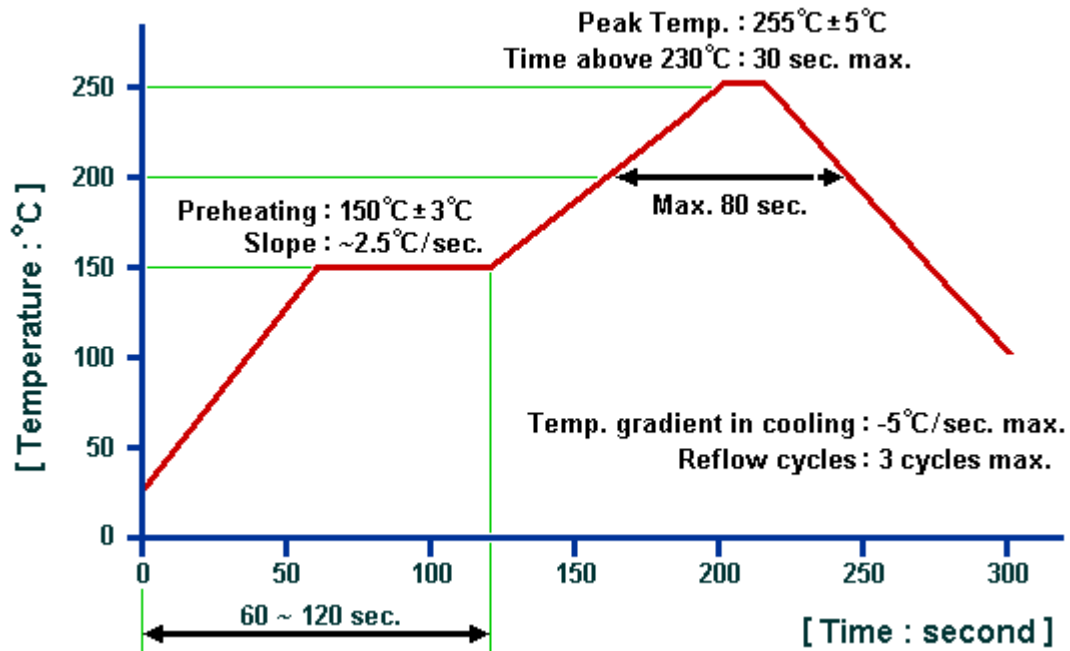

© DQHUAYING 2018. All Rights Reserved.

1. The specifications of this device are subject to change or obsolescence without notice.
2. Typically, equipment utilizing this device requires emissions testing and government approval, which is the responsibility of the equipment manufacturer.
3. Our liability is only assumed for the Surface Acoustic Wave (SAW) component(s) per se, not for applications, processes and circuits implemented within components or assemblies.
4. For questions on technology, prices and delivery, please contact our sales offices or e-mail [sales@dquaying.com](mailto:sales@dquaying.com).