

Specification of MEMS Microphone (GGS3177 & Halogen-free)

Customer Name :
Customer Model :
GoerTek Model : SD18OB261-104

GoerTek Microelectronics	CUSTOMER APPROVAL												
<table style="width: 100%; border-collapse: collapse;"> <tr> <td style="width: 15%;"><u>DESIGN</u></td> <td style="width: 60%;"><u>Aaron</u></td> <td style="width: 25%; text-align: right;"><small>2021.05.15</small></td> </tr> <tr> <td><u>CHKD</u></td> <td><u>Samual</u></td> <td style="text-align: right;"><small>2021.05.15</small></td> </tr> <tr> <td><u>STANDARD</u></td> <td><u>Angela</u></td> <td style="text-align: right;"><small>2021.05.15</small></td> </tr> <tr> <td><u>APVD</u></td> <td><u>Roy</u></td> <td style="text-align: right;"><small>2021.05.15</small></td> </tr> </table>	<u>DESIGN</u>	<u>Aaron</u>	<small>2021.05.15</small>	<u>CHKD</u>	<u>Samual</u>	<small>2021.05.15</small>	<u>STANDARD</u>	<u>Angela</u>	<small>2021.05.15</small>	<u>APVD</u>	<u>Roy</u>	<small>2021.05.15</small>	
<u>DESIGN</u>	<u>Aaron</u>	<small>2021.05.15</small>											
<u>CHKD</u>	<u>Samual</u>	<small>2021.05.15</small>											
<u>STANDARD</u>	<u>Angela</u>	<small>2021.05.15</small>											
<u>APVD</u>	<u>Roy</u>	<small>2021.05.15</small>											

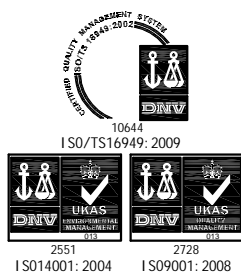

Tel : + 86 536 3051234
E- Mail : goertek@goertek.com
Website: <http://www.goertek.com>
Address: No.268 Dongfang Road, High-Tech Industry
Development District, Weifang, Shandong, P.R.C.

Contents

1	Introduction	4
2	Test Condition	4
3	Acoustical and Electrical Characteristics	4
3.1	Standard Performance Mode	4
3.2	Frequency Response Curve and Limits	4
3.3	Low Power Mode	5
3.4	General Microphone Specification	5
3.5	Micronphone Interface Specifications	6
4	Measurement Circuit	7
5	Test Setup Drawing	7
6	Mechanical Characteristics	8
6.1	Appearance Drawing	8
6.2	Weight	8
7	Reliability Test	9
7.1	Vibration Test	9
7.2	Drop Test	9
7.3	Temperature Test	9
7.4	Humidity Test	9
7.5	Mechanical Shock Test	9
7.6	Thermal Shock Test	9
7.7	Reflow Test	9
7.8	ESD Shock Test	9
8	Package	10
8.1	Tape Specification	10
8.2	Reel Dimension	11
8.3	The Content of Box	11
8.4	Packing Explain	12
9	Storage and Transportation	12
10	Land Pattern Recommendation	13
10.1	The Pattern of MIC Pad	13
10.2	Recommended Soldering Surface Land Pattern	13
11	Soldering Recommendation	14
11.1	Soldering Machine Condition	14
11.2	The Drawing and Dimension of Nozzle	14
11.3	Reflow Profile	15
11.4	Rework	16
12	Cautions When Using MEMS MIC	16
12.1	Board Wash Restrictions	16
12.2	Sound Hole Productions	16
12.3	Wire Width Adaption	16
12.4	Ultrasonic Restrictions	16
13	Output Inspection Standard	16

1 Introduction:

MEMS MIC which is able to endure reflow temperature up to 260 °C for 50 seconds can be used in SMT process. It is widely used in telecommunication and electronics device such as mobile phone, MP3, PDAs etc.

2 Test Condition (L=50 cm)

StandardConditions (As IEC 60268-4)	Temperature	Humidity	Air pressure
Environment Conditions	+15°C~+35°C	25%RH~75%RH	86kPa~106kPa
Basic Test Conditions	+20°C±2°C	60%RH~70%RH	86kPa~106kPa

3 Acoustical and Electrical Characteristics

3.1 Standard Performance Mode (Test Condition: V_{DD}=1.8V, f_{CLK}=2.4MHz)

Item	Symbol	Test Conditions	Min	Typ	Max	Unit
Sensitivity	S	f=1kHz, P _{in} =1Pa	-27	-26	-25	dBFS (Note 1)
Current Consumption (Note 2)	I	f _{clk} =2.4MHz	-	750	900	μA
S/N Ratio	SNR	f=1kHz, P _{in} =1Pa A-Weighted Curve	-	65	-	dB
Distortion	THD	94dB SPL @ 1kHz	-	0.1	1	%
Acoustic Overload Point	AOP	10% THD @1 kHz	-	120	-	dB SPL
Power Supply Rejection	PSR	100mVpp squarewave @217Hz, A-weighted	-	-80	-	dBFS
Power Supply Rejection Ratio	PSRR	200mVpp Sine wave @1KHz	-	60	-	dBFS

3.2 Frequency Response Curve and Limits

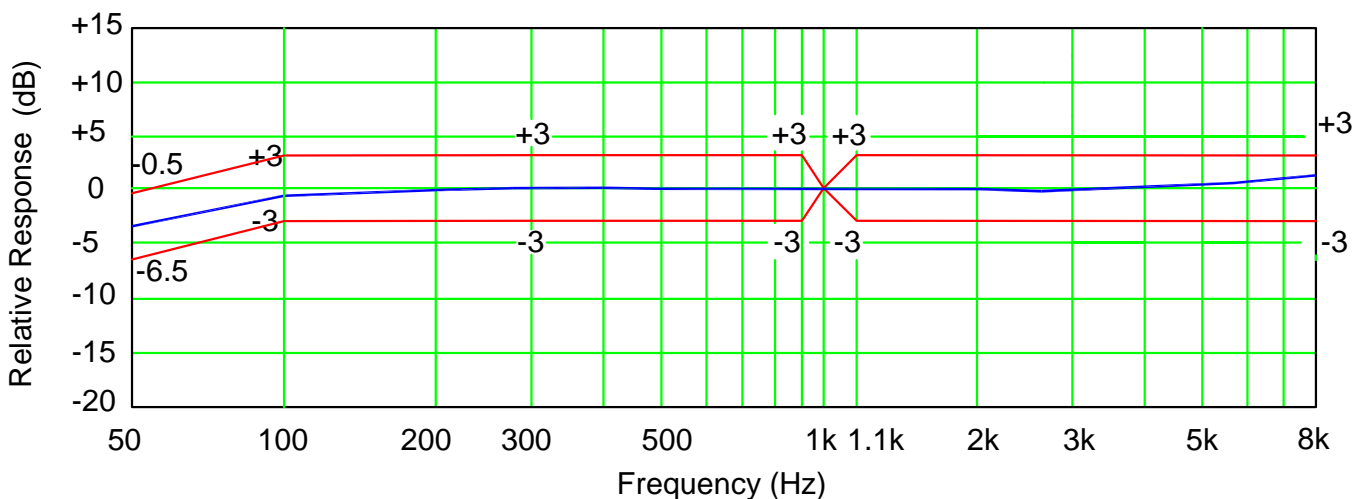

3.3 Low Power Mode (Test Condition: $V_{DD}=1.8V$, $f_{CLK}=768kHz$)

Item	Symbol	Test Conditions	Min	Typ	Max	Unit
Sensitivity	S	$f=1kHz$, $P_{in}=1Pa$	-27	-26	-25	dBFS (Note 1)
Current Consumption (Note 2)	I	$f_{clk}=768kHz$	-	300	350	μA
S/N Ratio	SNR	$f=1kHz$, $P_{in}=1Pa$ A-Weighted Curve	-	64	-	dB
Distortion	THD	94dB SPL @ 1kHz	-	0.2	1	%
Acoustic Overload Point	AOP	10% THD @ 1 kHz	-	120	-	dB SPL
Power Supply Rejection	PSR	100mVpp squarewave @217Hz, A-weighted	-	-86	-	dBFS
Power Supply Rejection Ratio	PSRR	200mVpp Sine wave @1KHz	-	60	-	dBFS

3.4 General Microphone Specifications

Test Condition: $V_{DD}=1.8V$, $f_{CLK}=2.4MHz$, select pin grounded, no load.

Item	Symbol	Test Conditions	Min	Typ	Max	Unit
Supply Voltage	V_{DD}		1.60	-	3.6	V
Clock Frequency Range	Standby Mode		0		50	kHz
	Lower Power Mode		150	768	900	kHz
	Normal Mode		1.0	-	4.8	MHz
Sleep Current	I_{sleep}	$F_{clk}=0Hz$, $V_{dd}=1.8V$	-	3		μA
Directivity			Omnidirectional			
Polarity		Increasing Sound	Increasing density of 1's			
Data Format			PDM			
Short Circuit Current	I_{SC}	Ground Data Pin			20	mA
Output Load	C_{load}				140	pF
Fall Asleep Time	T_{isp}	$F_{clk}<50KHz$		5		us
Wake-up Time	T_{wk}	$\pm 0.5dB$ sensitivity accuracy			20	ms
Power Up Time	T_{pu}	$\pm 0.5dB$ sensitivity accuracy			20	ms
Mode Change Time	T_{mc}	$\pm 0.5dB$ sensitivity accuracy			20	ms

3.5 Microphone Interface Specifications

Item	Symbol	Test Conditions	Min	Typ	Max	Unit
Supply Voltage	V_{DD}		1.60	-	3.6	V
Clock Frequency Range	Standby Mode		0		50	kHz
	Lower Power Mode		150	768	900	kHz
	Normal Mode		1.0	-	4.8	MHz
Sleep Current	I_{sleep}	Fclk=0Hz, Vdd=1.8V	-	3		μA
Directivity			Omnidirectional			
Polarity		Increasing Sound	Increasing density of 1's			
Data Format			PDM			
Short Circuit Current	I_{SC}	Ground Data Pin			20	mA
Output Load	C_{load}				140	pF
Fall Asleep Time	T_{lsp}	Fclk<50KHz		5		us
Wake-up Time	T_{wk}	$\pm 0.5dB$ sensitivity accuracy			20	ms
Power Up Time	T_{pu}	$\pm 0.5dB$ sensitivity accuracy			20	ms
Mode Change Time	T_{mc}	$\pm 0.5dB$ sensitivity accuracy			20	ms

Note 1. $dBFS = 20 \times \log(A/B)$ where A is the level of the signal, B is the level that corresponds to Full-scale level.

Note 2. The current consumption depends on the applied Clock Frequency and the load on the DATA output.

Note 3. Timing

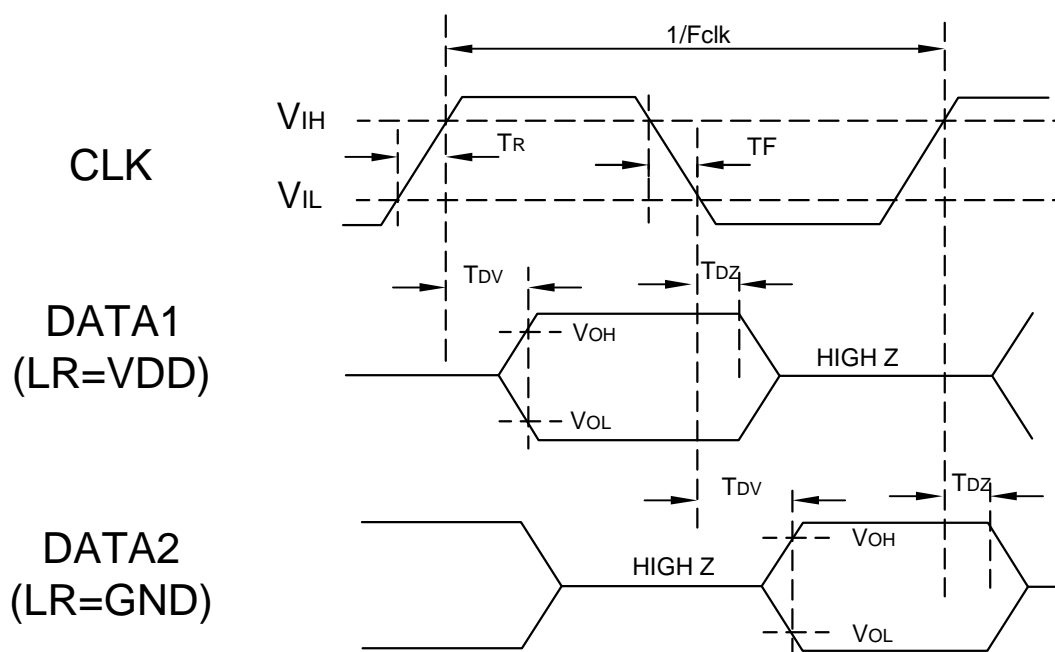

4 Measurement Circuit

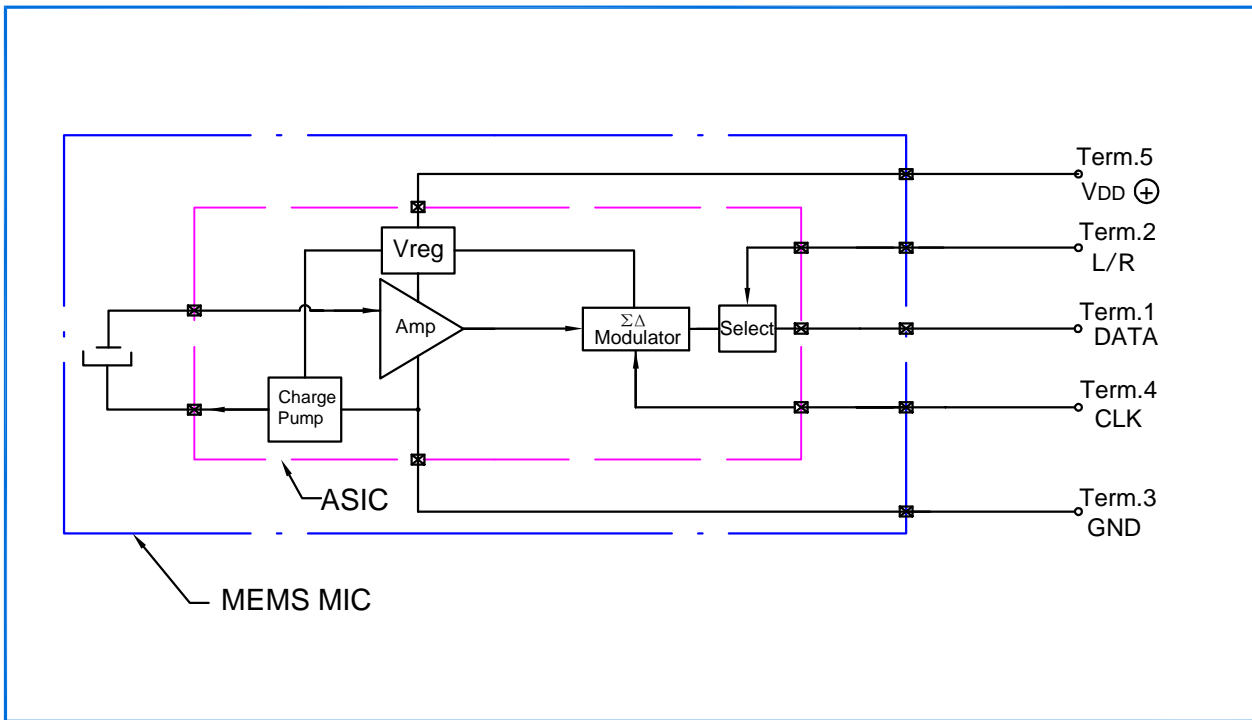

5 Test Setup Drawing

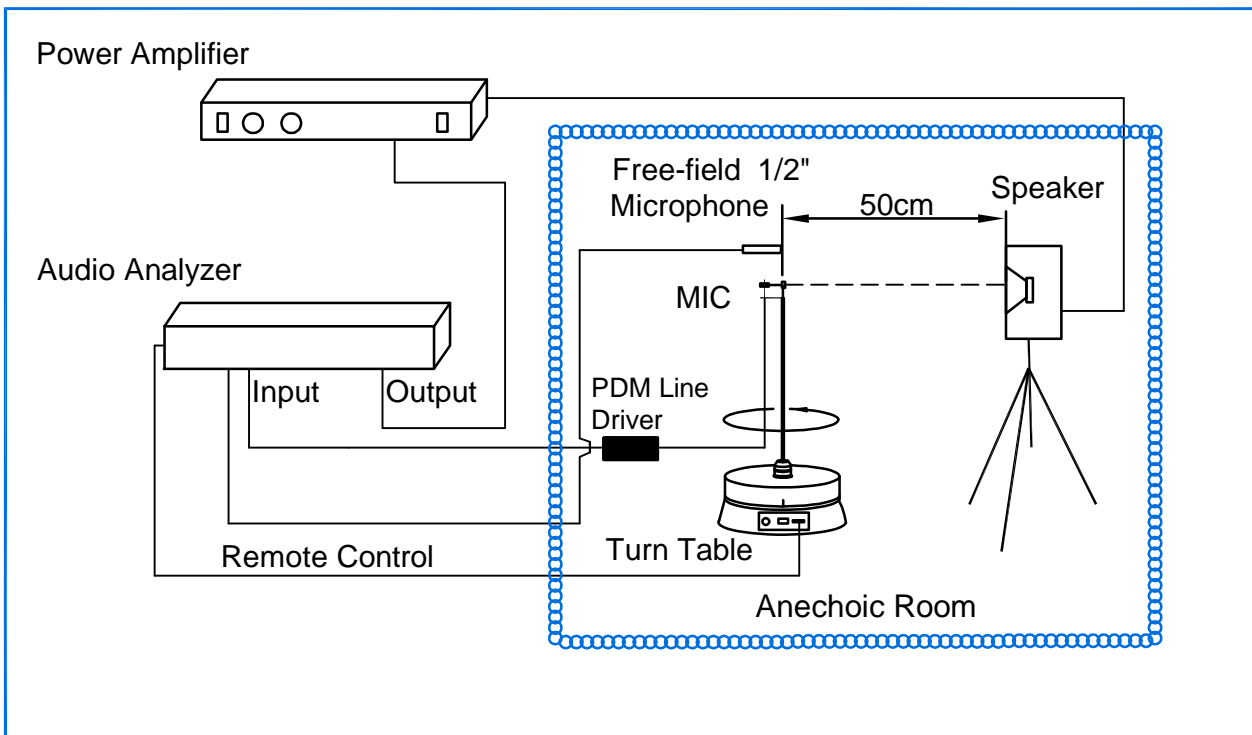

6 Mechanical Characteristics

6.1 Appearance Drawing (Unit: mm)

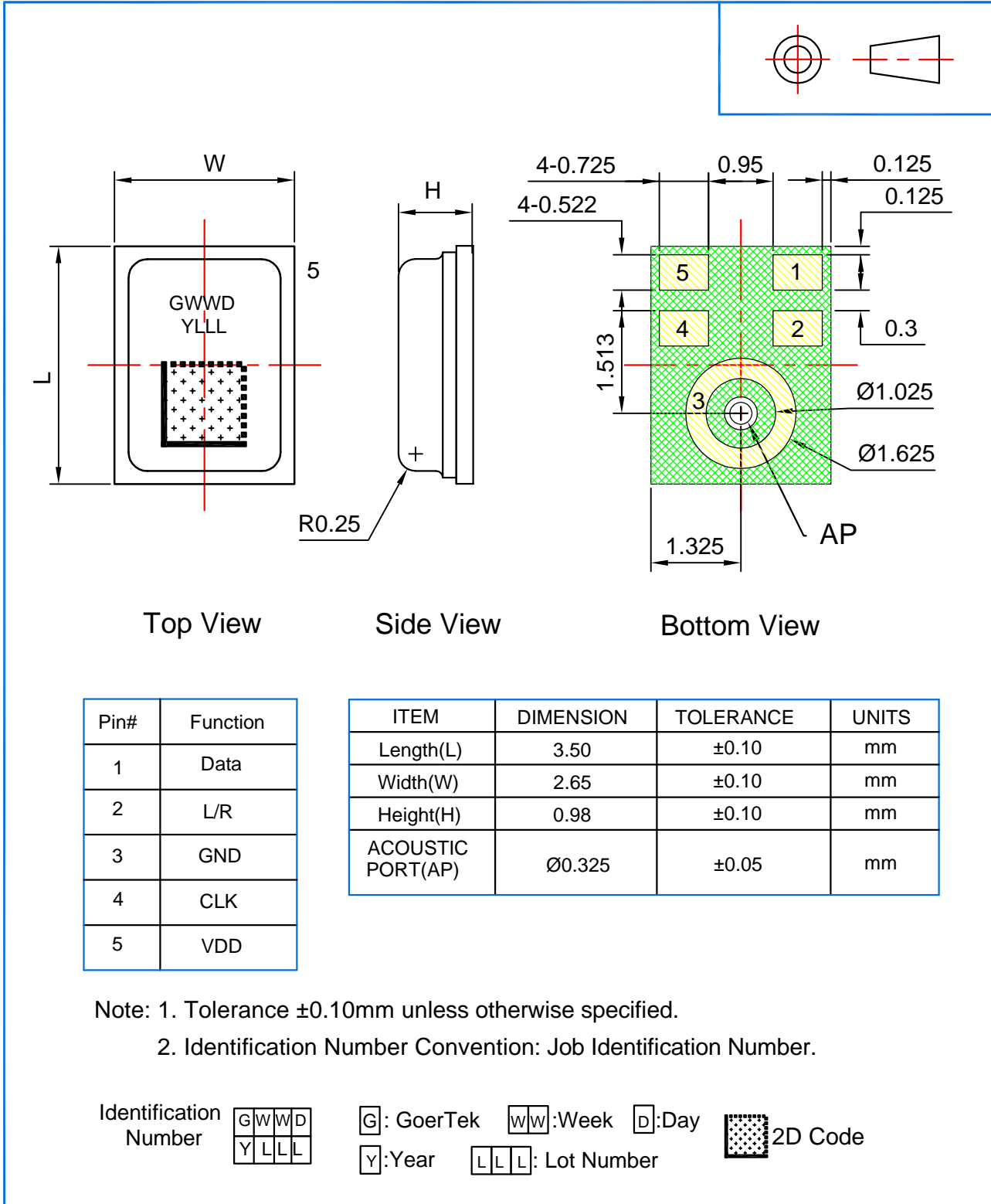

6.2 Weight

The weight of the MIC is Less than 0.05g.

7 Reliability Test

<p>7.1 Vibration Test</p>	<p>To be no interference in operation after vibrations, 4 cycles, from 20 to 2000HZ in each direction (X,Y,Z), 48min, user acceleration of 20g, sensitivity should vary within $\pm 3\text{dB}$ from initial sensitivity. (The measurement to be done after 2 hours of conditioning at $+15\text{ }^{\circ}\text{C} \sim +35\text{ }^{\circ}\text{C}$, R.H 25% \sim 75%)</p>
<p>7.2 Drop Test</p>	<p>To be no interference in operation after dropped to 1.0 cm steel plate 12 times from 1.5 meter height in state of JIG,JIG weight of 100 g, sensitivity should vary within $\pm 3\text{dB}$ from initial sensitivity. (The measurement to be done after 2 hours of conditioning at $+15\text{ }^{\circ}\text{C} \sim +35\text{ }^{\circ}\text{C}$, R.H 25% \sim 75%)</p>
<p>7.3 Temperature Test</p>	<p>a) After exposure at $+125\text{ }^{\circ}\text{C}$ for 200h, sensitivity should vary within $\pm 3\text{dB}$ from initial sensitivity. (The measurement to be done after 2h of conditioning at $+15\text{ }^{\circ}\text{C} \sim +35\text{ }^{\circ}\text{C}$, R.H 25% \sim 75%) b) After exposure at $-40\text{ }^{\circ}\text{C}$ for 200h, sensitivity should vary within $\pm 3\text{dB}$ from initial sensitivity. (The measurement to be done after 2 hours of conditioning at $+15\text{ }^{\circ}\text{C} \sim +35\text{ }^{\circ}\text{C}$, R.H 25% \sim 75%)</p>
<p>7.4 Humidity Test</p>	<p>After exposure at $+85\text{ }^{\circ}\text{C}$ and 85% relative humidity for 200 hours, sensitivity should vary within $\pm 3\text{dB}$ from initial sensitivity. (The measurement to be done after 2 hours of conditioning at $+15\text{ }^{\circ}\text{C} \sim +35\text{ }^{\circ}\text{C}$, R.H 25% \sim 75%)</p>
<p>7.5 Mechanical Shock Test</p>	<p>Then subject samples to three one-half sine shock pulses (3000 g for 0.3 milliseconds) in each direction (for six axes in total) along each of the three mutually perpendicular axes for a total of 18 shocks, sensitivity should vary within $\pm 3\text{dB}$ from initial sensitivity. (The measurement to be done after 2 hours of conditioning at $+15\text{ }^{\circ}\text{C} \sim +35\text{ }^{\circ}\text{C}$, R.H 25% \sim 75%)</p>
<p>7.6 Thermal Shock Test</p>	<p>After exposure at $-40\text{ }^{\circ}\text{C}$ for 30min, at $+125\text{ }^{\circ}\text{C}$ for 30min (change time 20 seconds) 32 cycles, sensitivity should vary within $\pm 3\text{dB}$ from initial sensitivity. (The measurement to be done after 2 hours of conditioning at $+15\text{ }^{\circ}\text{C} \sim +35\text{ }^{\circ}\text{C}$, R.H 25% \sim 75%)</p>
<p>7.7 Reflow Test</p>	<p>Adopt the reflow curve of item 12.3, after three reflows, sensitivity should vary within $\pm 3\text{dB}$ from initial sensitivity. (The measurement to be done after 2 hours of conditioning at $+15\text{ }^{\circ}\text{C} \sim +35\text{ }^{\circ}\text{C}$, R.H 25% \sim 75%)</p>
<p>7.8 ESD Shock Test</p>	<p>Under $C=150\text{pF}$, $R=330\text{ohm}$. Tested to $\pm 8\text{KV}$ contact to the case and tested to $\pm 2\text{kV}$ contact to I/O terminals.10 times. Grounding. Sensitivity should vary within $\pm 3\text{dB}$ from initial sensitivity. (The measurement to be done after 2 hours of conditioning at $+15\text{ }^{\circ}\text{C} \sim +35\text{ }^{\circ}\text{C}$, R.H.25% \sim 75%)</p>

8 Package

8.1 Tape Specification

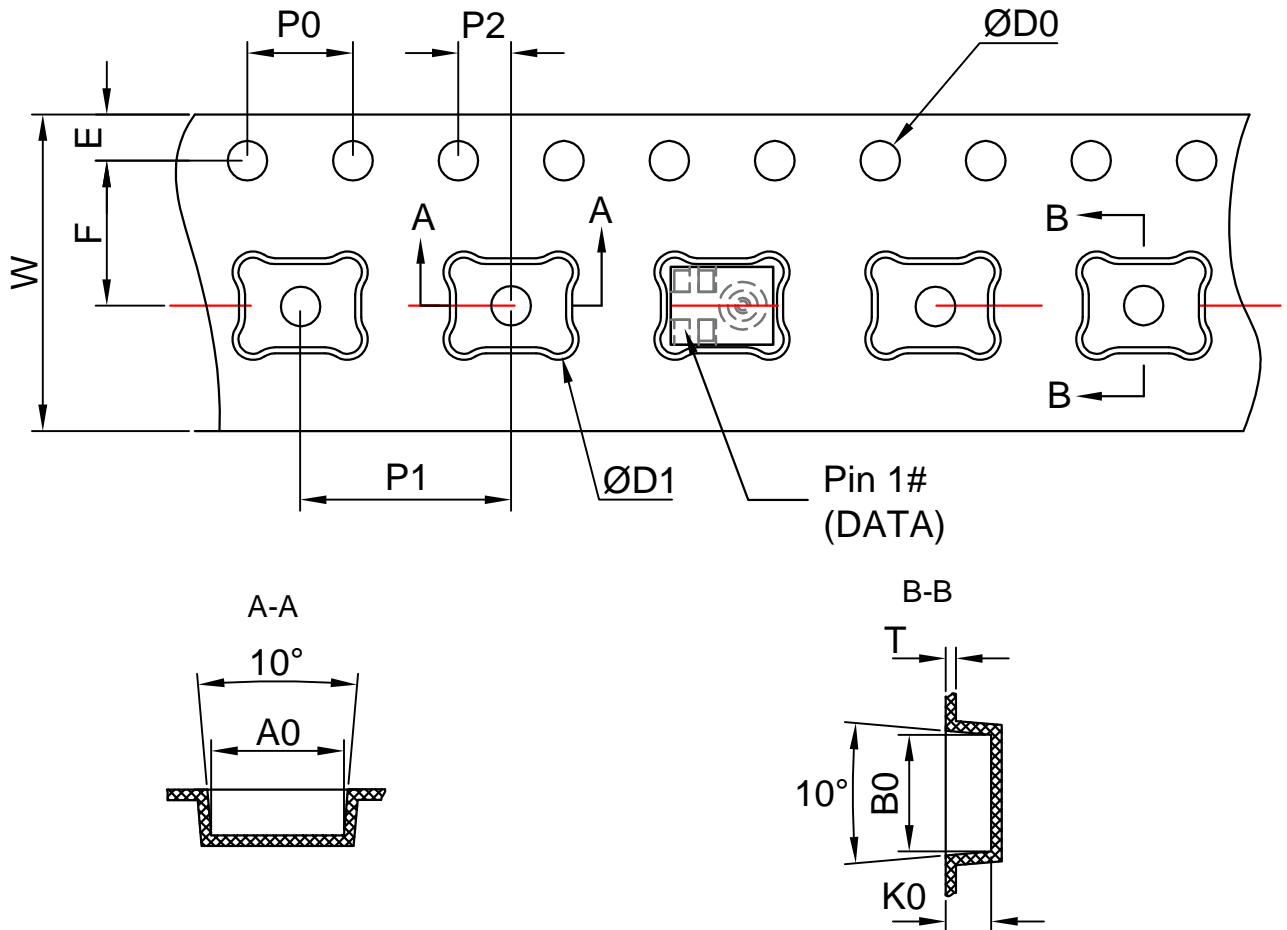

The Dimensions as Follows:

ITEM	W	E	F	ØD0	ØD1
DIM(mm)	12.0±0.30	1.75±0.10	5.5±0.05	1.50 ^{+0.10} ₀	0.50±0.10
ITEM	P0	10P0	P1	A0	B0
DIM(mm)	4.00±0.10	40.00±0.20	8.00±0.10	3.75±0.05	2.85±0.05
ITEM	K0	P2	T		
DIM(mm)	1.30±0.10	2.00±0.05	0.30±0.05		

8.2 Reel Dimension

7" reel for sample stage

13" reel will be provided for the mass production stage

The following is 13" reel dimensions (unit:mm)

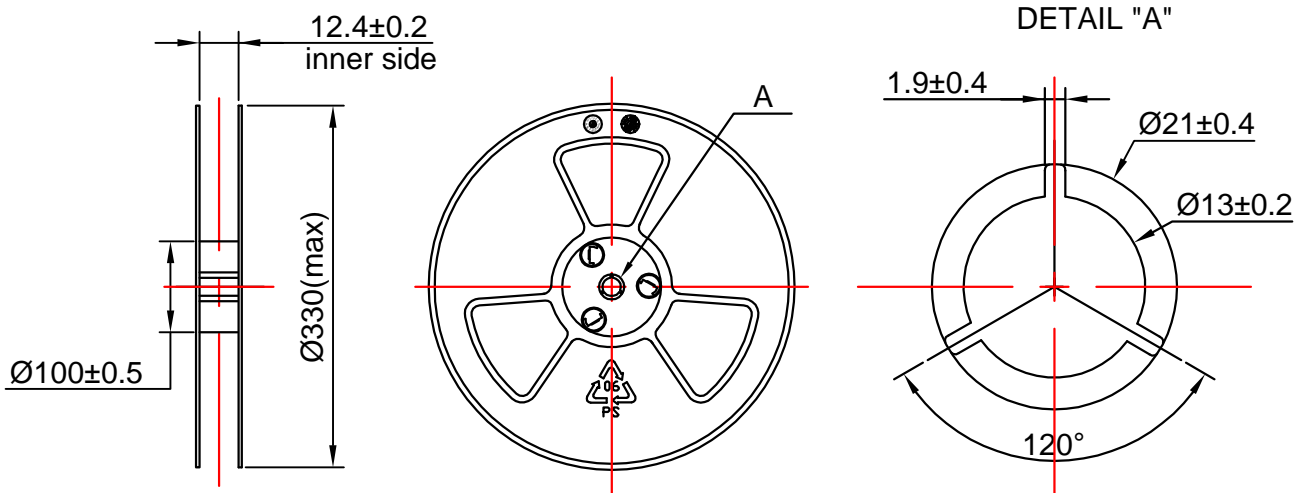

8.3 The Content of Box(13" reel)

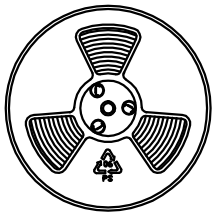

Packing (5,000PCS)

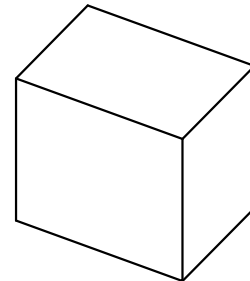
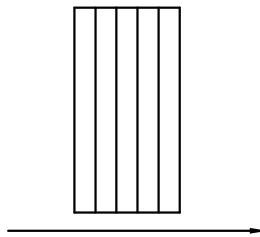

Inner Box(25,000PCS)
(340mm×135mm×355mm)

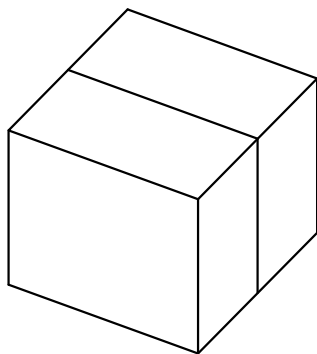

Two Inner Box(50,000PCS)

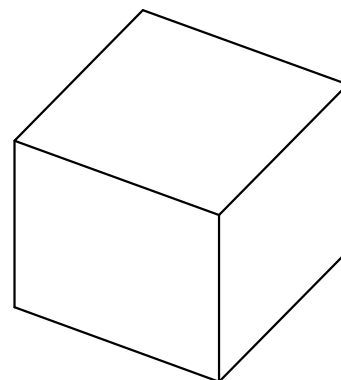

Outer Box(50,000PCS)
(370mm×300mm×390mm)

8.4 Packing Explain

8.4.1 The Label Content of the Reel

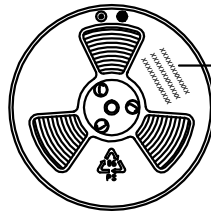

The Content Includes:
Product type, Lot, Customer P/N;
and other essential information such as
Quantity, Date etc.

8.4.2 The RoHS Label

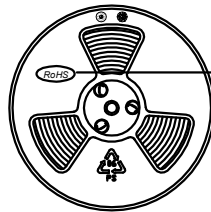

RoHS Compliance &
Halogen Free Mark

9 Storage and Transportation

- 9.1 Keep MEMS MIC in warehouse with less than 75% humidity and without sudden temperature change, acid air, any other harmful air or strong magnetic field. Recommend storage period no more than 1 year and floor life(out of bag) at factory no more than 4 weeks.
- 9.2 The MEMS MIC with normal pack can be transported by ordinary conveyances. Please protect products against moist, shock, sunburn and pressure during transportation.
- 9.3 Storage Temperature Range : -40°C ~ +70°C
- 9.4 Operating Temperature Range : -40°C ~ +100°C

10 Land Pattern Recommendation

10.1 The Pattern of MIC Pad(Unit:mm)

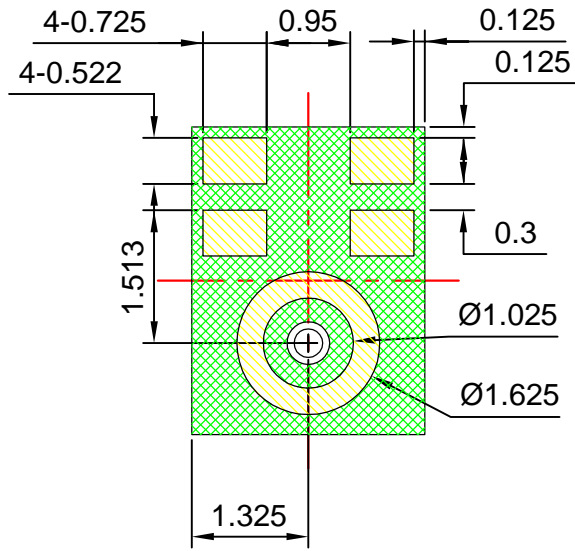

10.2 Recommended Soldering Surface Land Pattern (Unit:mm)

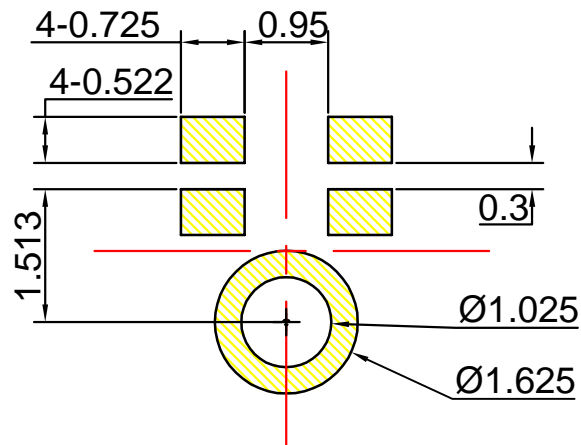

11 Soldering Recommendation

11.1 Soldering Machine Condition

Temperature Control	8 zones
Heater Type	Hot Air
Solder Type	Lead-free

11.2 The Drawing and Dimension of Nozzle

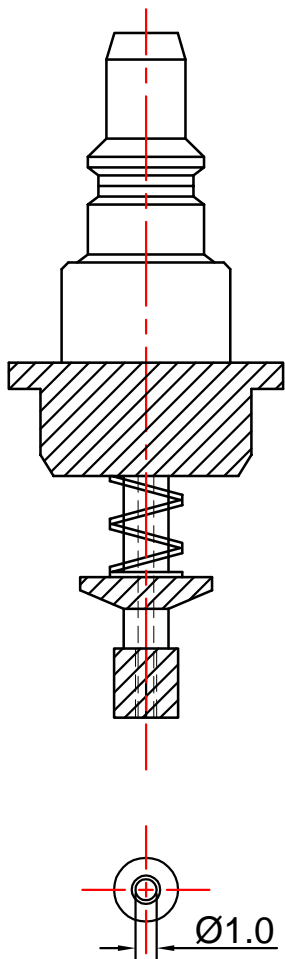

Inside Diameter: 1.0mm;

Please don't vacuum over the acoustic port directly.
Please don't blow the acoustic port directly.

11.3 Reflow Profile

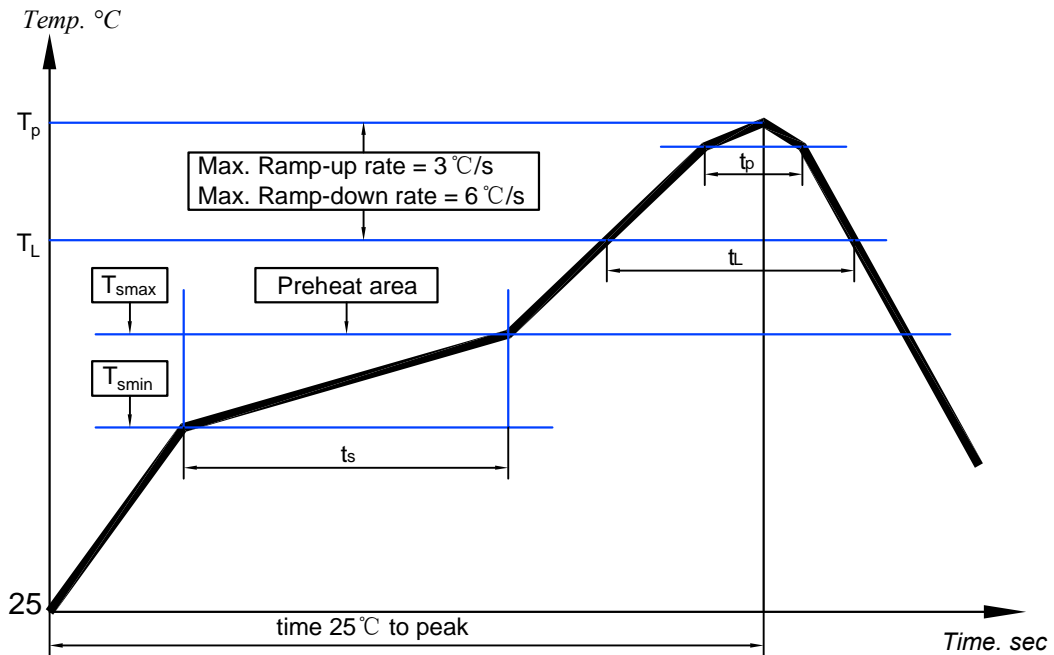

Key Features of The Profile:

Average Ramp-up rate(T_{smax} to T_p)	3°C/s max.
Preheat : Temperature Min(T_{smin}) Temperature Max(T_{smax}) Time(T_{smin} to T_{smax})(t_s)	150°C 200°C 60~180s
Time maintained above : Temperature(T_L) Time(t_L)	217°C 60~150s
Peak Temperature(T_p)	260°C
Time within 5°C of actual Peak Temperature(t_p) :	30~40s
Ramp-down rate(T_p to T_{smax})	6°C/s max
Time 25°C to Peak Temperature	8min max

When MEMS MIC is soldered on PCB, the reflow profile is set according to solder paste and the thickness of PCB etc.

11.4 Rework

- (1) 250°C ~ 270°C, maximum 30 sec, Peak temperature 330°C.
- (2) Wind speed: 15L/m.
- (3) It is very important not to put a heatgun over the acoustic port of the microphone.

12 Cautions When Using MEMS MIC

12.1 Board Wash Restrictions

It is very important not to wash this silicon microphone, otherwise this could damage the microphone.

12.2 Sound Hole Protection

It is very important not to operate vacuum and air blow into sound hole (without any covering over sound holes), otherwise this could damage the microphone. And it is necessary to be careful about foreign substances into sound hole inside silicon microphone.

12.3 Wire width Adaption

It is needed to adjust the dumping resistance according to the wire length and wire tod, etc. when using. It is also necessary to insert dumping resistance in the Data line located adjacent to the microphone according to circumstances.

12.4 Ultrasonic Restrictions

It is very important not to use ultrasonic process. otherwise this could damage the microphone.

13 Output Inspection Standard

Output inspection standard is executed according to <<ISO2859-1:1999>>.