

### Product Summary

$V_{(BR)DSS}$	$R_{DS(on)MAX}$	$I_D$
20V	380mΩ@4.5V	0.75A
	450mΩ@2.5V	
	800mΩ@1.8V	

### Feature

- Surface Mount Package
- N-Channel Switch with Low  $R_{DS(on)}$
- Operated at Low Logic Level Gate Drive

### Application

- Load/Power Switching
- Interfacing Switching
- Battery Management for Ultra Small Portable Electronics
- Logic Level Shift

### MARKING:

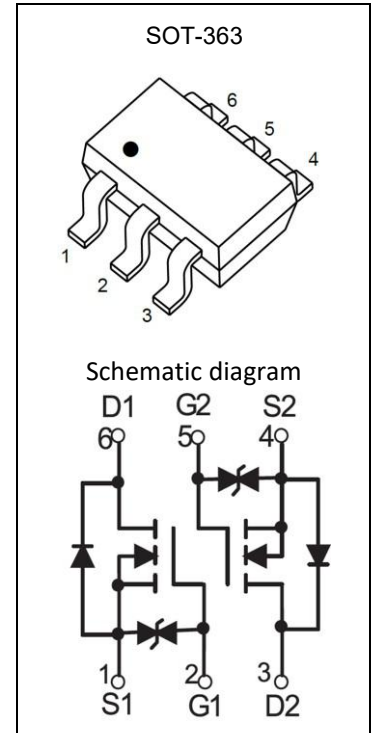
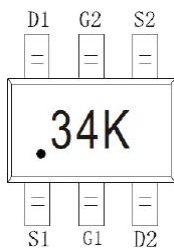

### ABSOLUTE MAXIMUM RATINGS ( $T_a=25^\circ\text{C}$ unless otherwise noted)

Parameter	Symbol	Value	Unit
Drain-Source Voltage	$V_{DS}$	20	V
Gate-Source Voltage	$V_{GS}$	$\pm 12$	V
Continuous Drain Current <sup>(1)</sup>	$I_D$	0.75	A
Power Dissipation <sup>(1)</sup>	$P_D$	150	mW
Thermal Resistance from Junction to Ambient <sup>(1)</sup>	$R_{\theta JA}$	833	$^\circ\text{C}/\text{W}$
Junction Temperature	$T_J$	150	$^\circ\text{C}$
Storage Temperature	$T_{STG}$	-55~+150	$^\circ\text{C}$

**MOSFET ELECTRICAL CHARACTERISTICS**( $T_a=25^\circ\text{C}$  unless otherwise noted)

Parameter	Symbol	Test Condition	Min	Type	Max	Unit
<b>Static Characteristics</b>						
Drain-source breakdown voltage	$V_{(BR)DSS}$	$V_{GS} = 0V, I_D = 250\mu A$	20			V
Zero gate voltage drain current	$I_{DSS}$	$V_{DS} = 20V, V_{GS} = 0V$			1	$\mu A$
Gate-body leakage current	$I_{GSS}$	$V_{GS} = \pm 10V, V_{DS} = 0V$			$\pm 20$	$\mu A$
Gate threshold voltage <sup>(1)</sup>	$V_{GS(th)}$	$V_{DS} = V_{GS}, I_D = 250\mu A$	0.35	0.75	1.1	V
Drain-source on-resistance <sup>(1)</sup>	$R_{DS(on)}$	$V_{GS} = 4.5V, I_D = 650mA$		190	380	m $\Omega$
		$V_{GS} = 2.5V, I_D = 550mA$		260	450	
		$V_{GS} = 1.8V, I_D = 450mA$		390	800	
Forward tranconductance <sup>(1)</sup>	$g_{FS}$	$V_{DS} = 10V, I_D = 800mA$		1.6		S
<b>Dynamic characteristics</b> <sup>(2)</sup>						
Input Capacitance	$C_{iss}$	$V_{DS} = 16V, V_{GS} = 0V, f = 1MHz$			120	pF
Output Capacitance	$C_{oss}$				20	
Reverse Transfer Capacitance	$C_{rss}$				15	
<b>Switching Characteristics</b> <sup>(2)</sup>						
Turn-on delay time	$t_{d(on)}$	$V_{DS} = 10V, I_D = 500mA,$ $V_{GS} = 4.5V, R_G = 10\Omega$		6.7		ns
Turn-on rise time	$t_r$			4.8		
Turn-off delay time	$t_{d(off)}$			17.3		
Turn-off fall time	$t_f$			7.4		
<b>Source-Drain Diode characteristics</b>						
Diode Forward voltage <sup>(1)</sup>	$V_{DS}$	$I_S = 0.15A, V_{GS} = 0V$			1.2	V

**Notes:**

1. Pulse Test : Pulse width  $\leq 300\mu s$ , duty cycle  $\leq 0.5\%$ .
2. Guaranteed by design, not subject to production testing

## Typical Electrical and Thermal Characteristics

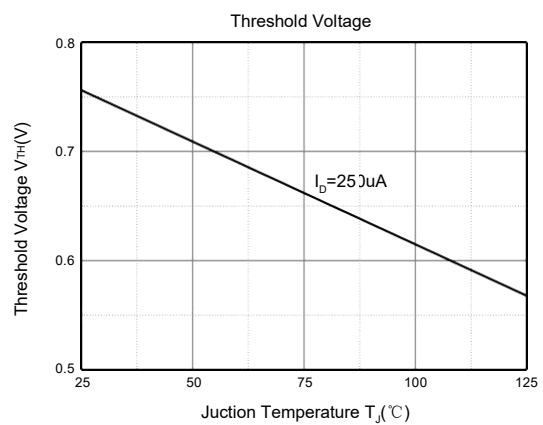
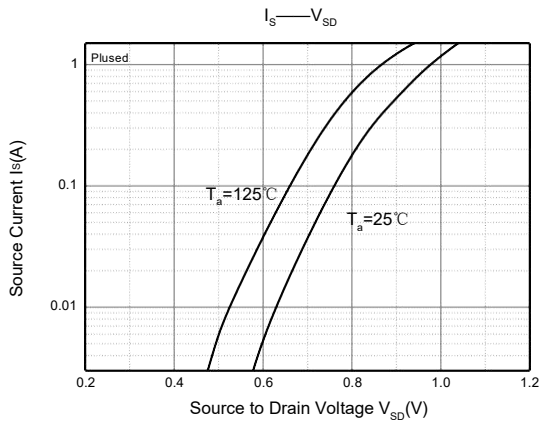
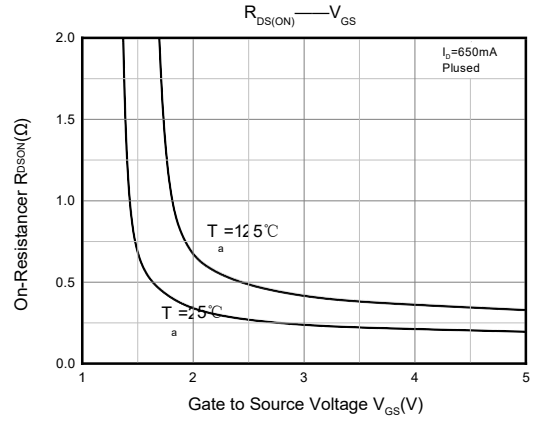
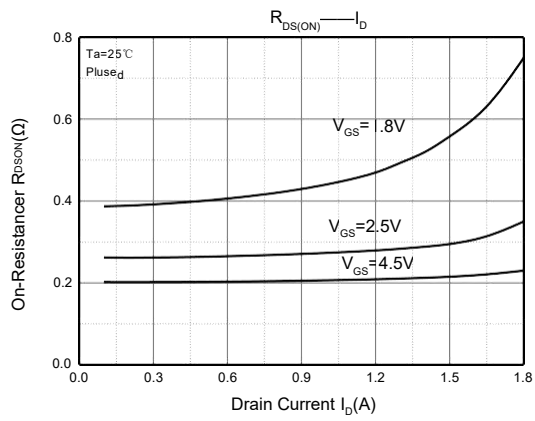
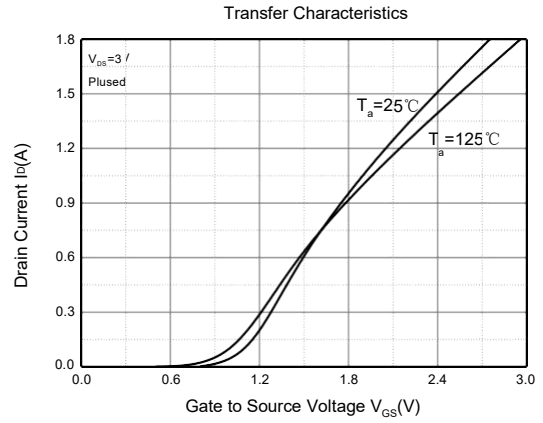
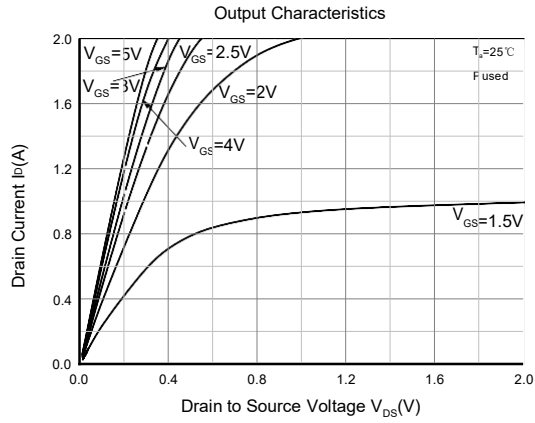

SOT-363 Package Information

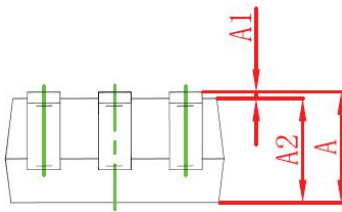
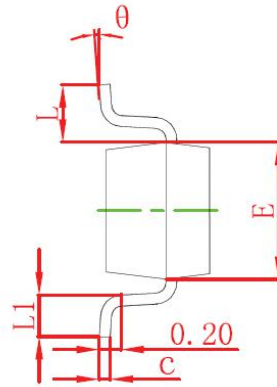
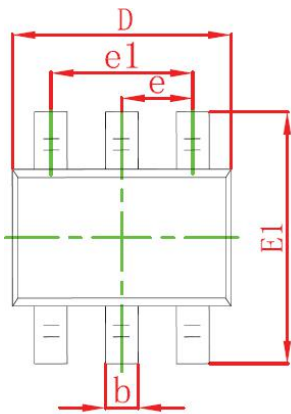

Symbol	Dimensions In Millimeters		Dimensions In Inches	
	Min	Max	Min	Max
A	0.900	1.100	0.035	0.043
A1	0.000	0.100	0.000	0.004
A2	0.900	1.000	0.035	0.039
b	0.150	0.350	0.006	0.014
c	0.100	0.150	0.004	0.006
D	2.000	2.200	0.079	0.087
E	1.150	1.350	0.045	0.053
E1	2.150	2.400	0.085	0.094
e	0.650 TYP		0.026 TYP	
e1	1.200	1.400	0.047	0.055
L	0.525 REF		0.021 REF	
L1	0.260	0.460	0.010	0.018
$\theta$	0°	8°	0°	8°

SOT-363 Tape and Reel

### SOT-363 Tape and reel

SOT-363 Embossed Carrier Tape

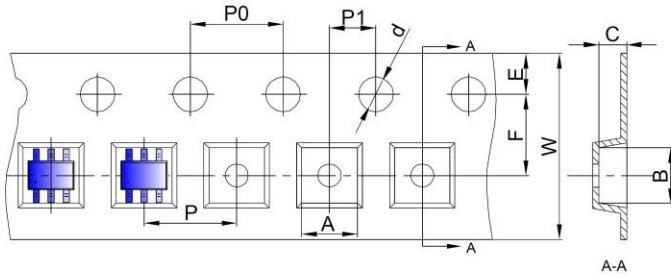

Dimensions are in millimeter										
Pkg type	A	B	C	d	E	F	P0	P	P1	W
SOT-363	2.25	2.55	1.20	Ø1.50	1.75	3.50	4.00	4.00	2.00	8.00

### SOT-363 Tape Leader and Trailer

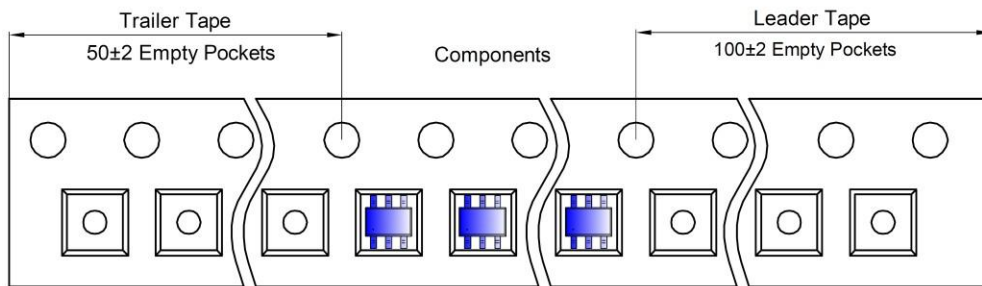

### SOT-363 Reel

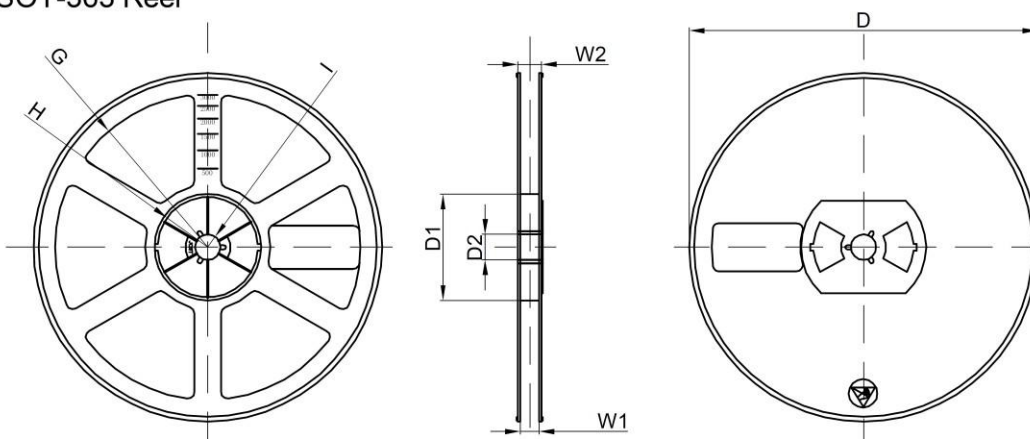

Dimensions are in millimeter								
Reel Option	D	D1	D2	G	H	I	W1	W2
7" Dia	Ø178.00	54.40	13.00	R78.00	R25.60	R6.50	9.50	12.30

REEL	Reel Size	Box	Box Size(mm)	Carton	Carton Size(mm)	G.W.(kg)
3000 pcs	7 inch	30,000 pcs	203×203×195	120,000 pcs	438×438×220	