

**■ Features**

- Molding Inductor.
- Low Profile,Low Temp.
- Large Current(Over 15A).
- Customize For Different Need.
- Operating temperature:-40℃ ~ +125℃.

**■ Applications**

- General Electronic.
- Video Device,TV,TFT.
- Power Module for PC.
- NB/Lap Top Computer.
- Server,VGA Card/Module.

**■ Product Identification**

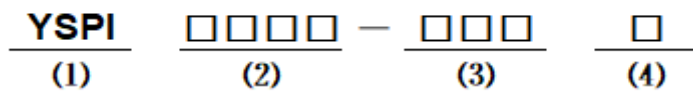

(1) : Type

(2) : Dimensions

(3) : Inductance value

(4) : Inductance Tolerance : N=±30%,M=±20% , K=±10%

**■ Shapes and Dimensions (Unit: mm)**

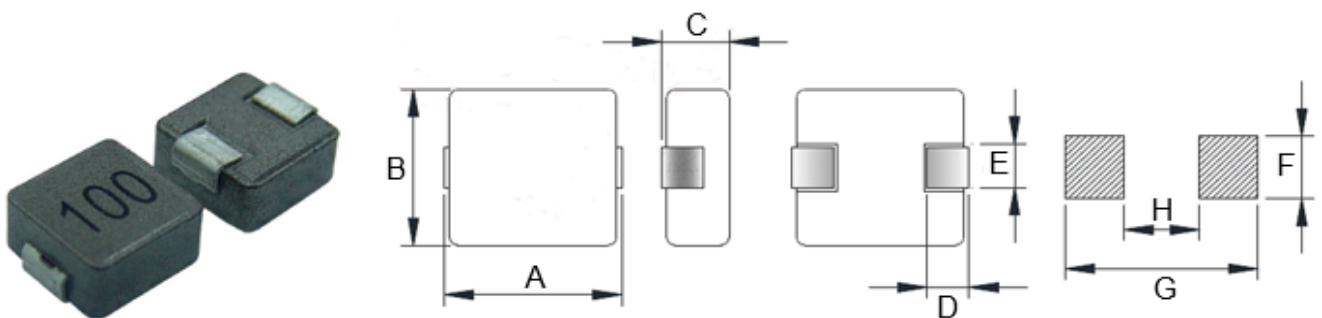

TYPE	A Max.	B	C Max.	D	E	F Ref.	G Ref.	H Ref.
YSPI1365	13.8	12.6±0.2	6.5	2.7±0.5	3.7±0.5	5.0	14.5	6.5

### ■ YSPI1365 Series

Part Number	Inductance (uH) @100KHz	DC Resistance (mΩ) Max.	Heat Rating Current (A)	Saturation Current (A)
YSPI1365-R47M	0.47	1.20	30.0	60.0
YSPI1365-1R0M	1.0	2.00	25.0	36.0
YSPI1365-1R5M	1.5	2.50	20.0	30.0
YSPI1365-2R2M	2.2	4.20	15.0	28.0
YSPI1365-3R3M	3.3	6.80	13.0	25.0
YSPI1365-4R7M	4.7	9.00	12.0	25.0
YSPI1365-5R6M	5.6	13.0	11.5	18.0
YSPI1365-6R8M	6.8	15.0	11.0	16.0
YSPI1365-100M	10	20.0	9.0	15.0
YSPI1365-150M	15	30.0	7.0	10.5
YSPI1365-220M	22	44.0	5.8	7.5
YSPI1365-330M	33	60.0	5.5	6.5
YSPI1365-470M	47	80.0	5.0	6.0
YSPI1365-680M	68	130	3.5	5.0
YSPI1365-101M	100	220	2.5	4.5

- ※ The saturation current value is the DC current value having inductance decrease down to 30%.(at 20°C)
- ※ The temperature rise current value is the DC current value having temperature increase up to 40°C. (at 20°C)
- ※ The rated current is the DC current value that satisfies both of current value saturation current value and temperature rise current value.

**■ Taping Dimensions(Unit:mm)**

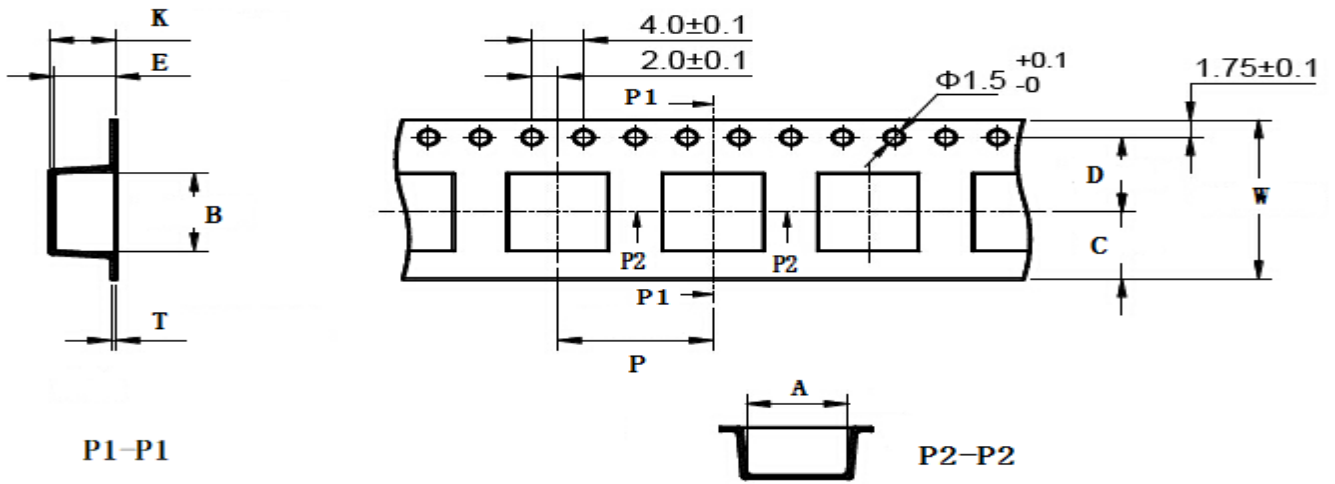

TYPE	W	A	B	C	D	E	P	K Ref	T	MPQ
YSPI1365	24±0.3	12.8±0.1	13.70±0.1	10.75	11.5±0.1	7.0±0.1	20±0.1	6.7	0.50±0.05	500

**■ Reel Dimensions(Unit:mm)**

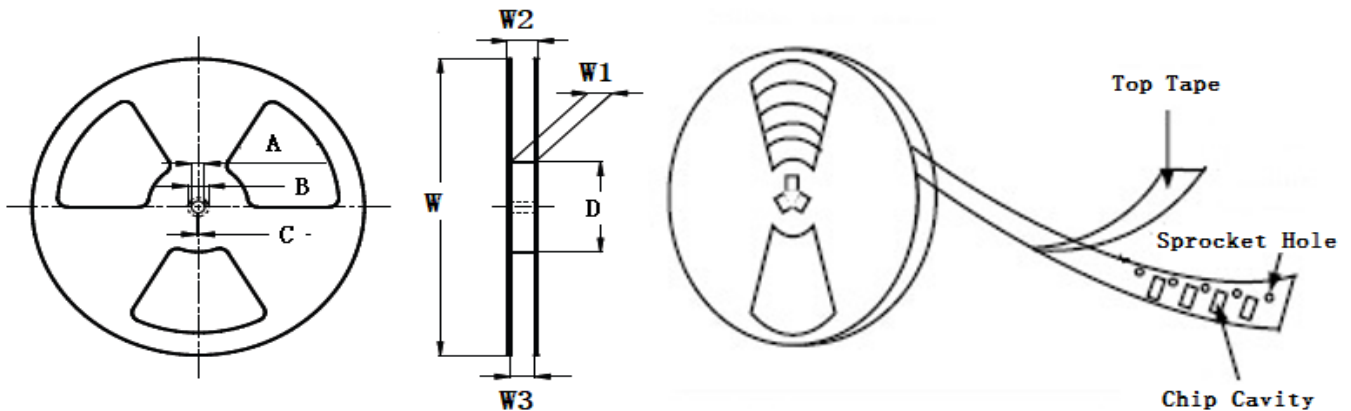

TYPE	W	W1	W2	W3	A	B	C	D
YSPI1365	330±2.0	24.4±1.5	30.4MAX	23.9 Min	13.0±0.50	21.0±0.80	2.0±0.50	100 Min

**Direction of rolling**

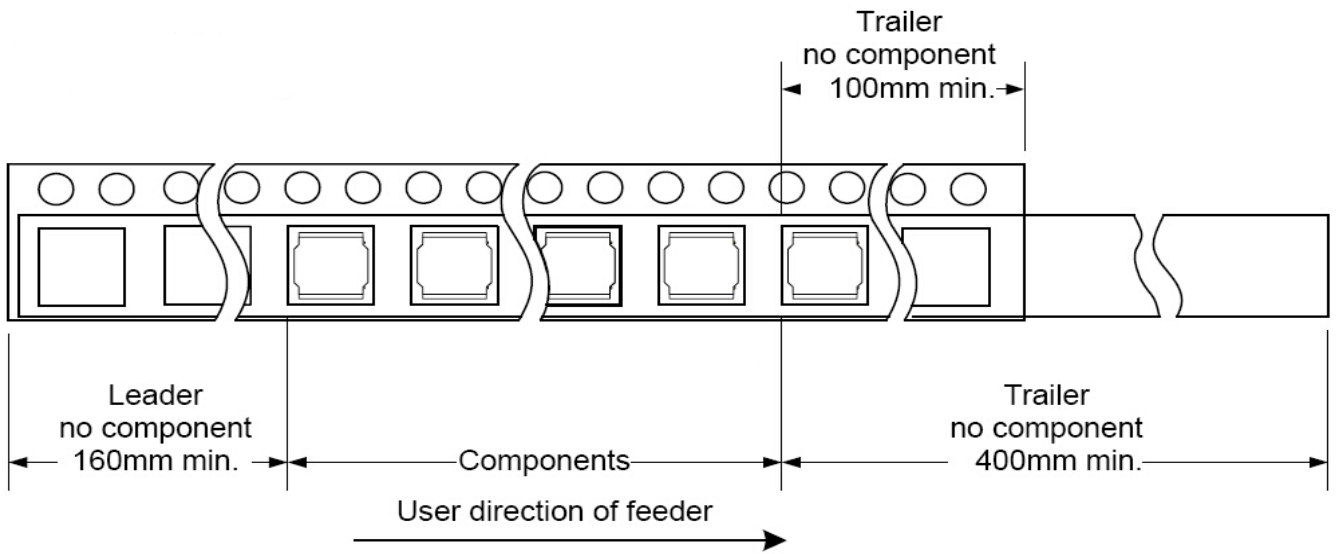

**Cover tape peel off condition**

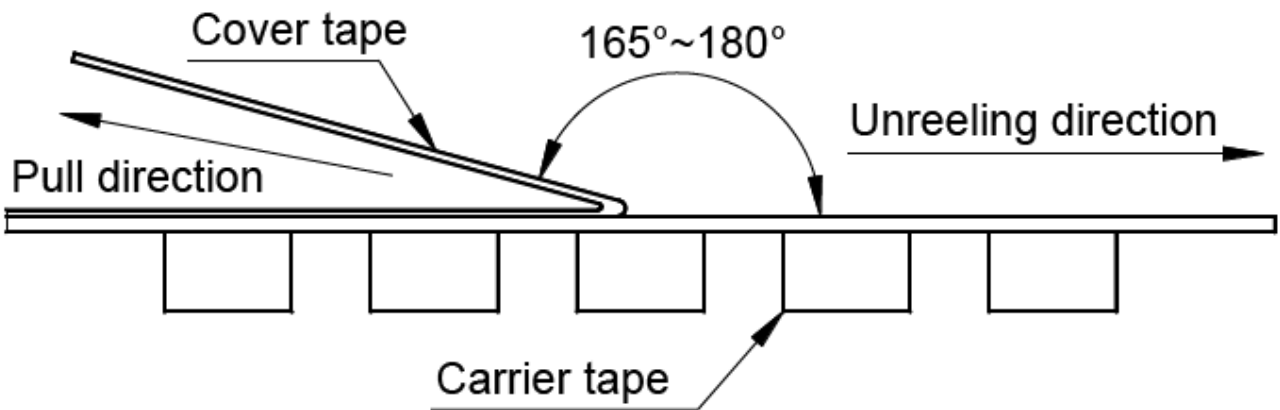

Cover tape peel force shall be 0.1N to 1.3N.

Reference peel speed  $300 \pm 10$ mm/min.