

## ■ Features

- Molding Inductor.
- Low Profile,Low Temp.
- Large Current(Over 15A).
- Customize For Different Need.
- Operating temperature:-40°C ~ +125°C.

## ■ Applications

- General Electronic.
- Video Device,TV,TFT.
- Power Module for PC.
- NB/Lap Top Computer.
- Server,VGA Card/Module.

## ■ Product Identification

$\frac{\text{YSPI}}{(1)} \quad \frac{\square\square\square\square}{(2)} - \frac{\square\square\square}{(3)} \quad \frac{\square}{(4)}$

(1) : Type

(2) : Dimensions

(3) : Inductance value

(4) : Inductance Tolerance : N=±30%,M=±20% , K=±10%

## ■ Shapes and Dimensions (Unit: mm)

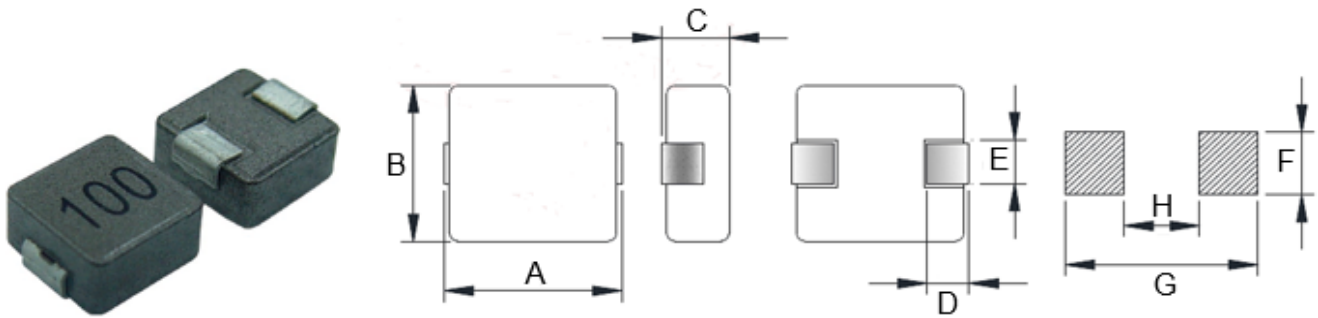

TYPE	A Max.	B	C Max.	D	E Ref.	F Ref.	G Ref.	H Ref.
YSPI1360	13.8	12.6±0.2	6.0	2.7±0.5	3.7±0.5	5.0	14.5	6.5

## ■ YSPI1360 Series

Part Number	Inductance (uH) @100KHz	DC Resistance (mΩ) Max.	Heat Rating Current (A)	Saturation Current (A)
YSPI1360-100M	10±20%	20.7	10.0	12.5
YSPI1360-150M	15±20%	32.0	6.0	9.0
YSPI1360-220M	22±20%	39.5	5.0	7.5
YSPI1360-470M	47±20%	95.0	3.5	5.5
YSPI1360-560M	56±20%	125	3.3	5.2
YSPI1360-680M	68±20%	134	3.2	5.0

- ※ The saturation current value is the DC current value having inductance decrease down to 30%. (at 20°C)
- ※ The temperature rise current value is the DC current value having temperature increase up to 40°C. (at 20°C)
- ※ The rated current is the DC current value that satisfies both of current value saturation current value and temperature rise current value.

**■ Taping Dimensions(Unit:mm)**

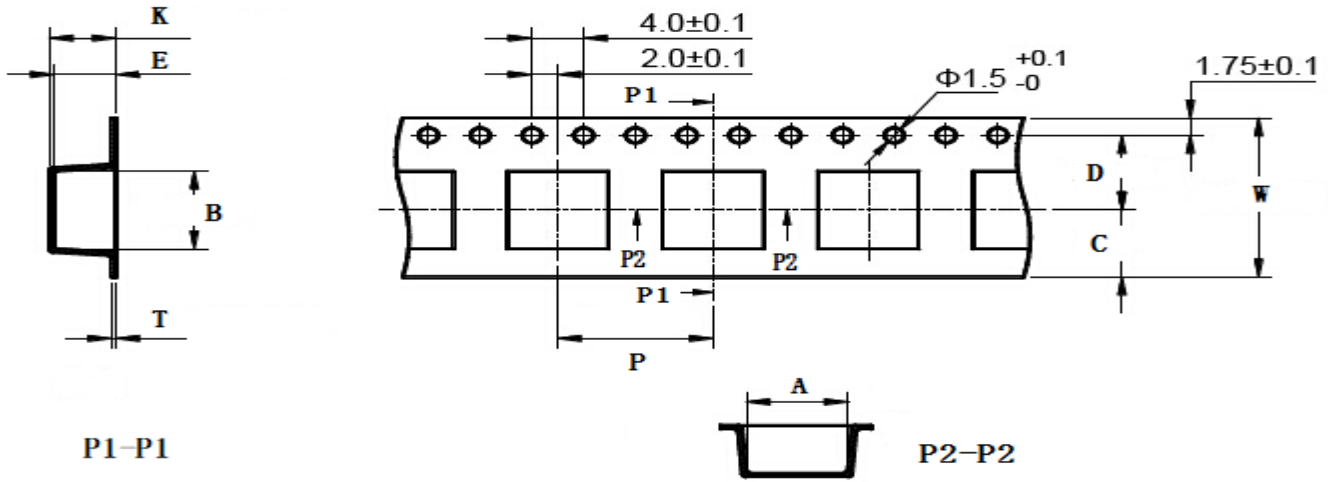

TYPE	W	A	B	C	D	E	P	K Ref	T	MPQ
YSPI1360	24±0.3	12.8±0.1	13.70±0.1	10.75	11.5±0.1	5.8±0.1	20±0.1	5.1	0.50±0.05	500

**■ Reel Dimensions(Unit:mm)**

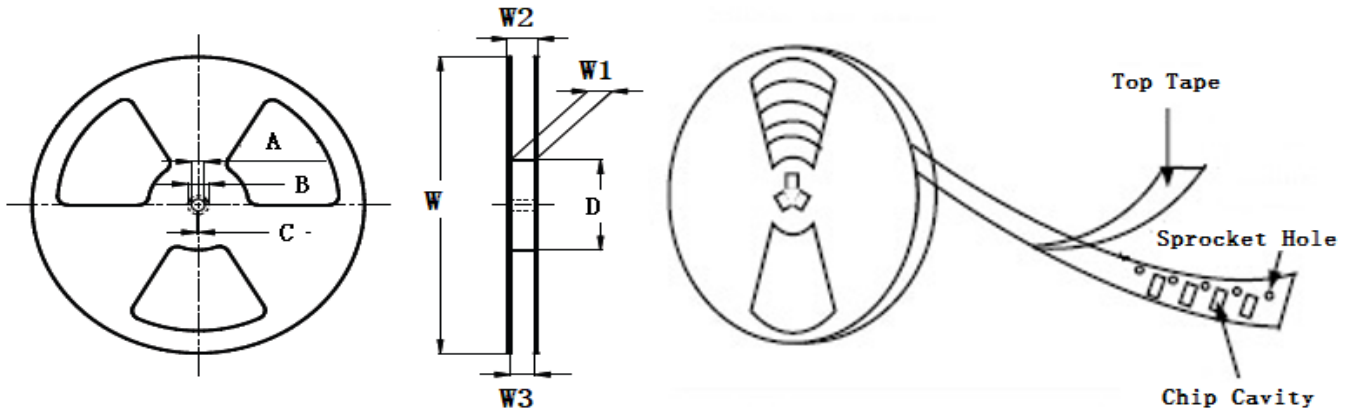

TYPE	W	W1	W2	W3	A	B	C	D
YSPI1360	330±2.0	24.4±1.5	30.4MAX	23.9 Min	13.0±0.50	21.0±0.80	2.0±0.50	100 Min

**Direction of rolling**

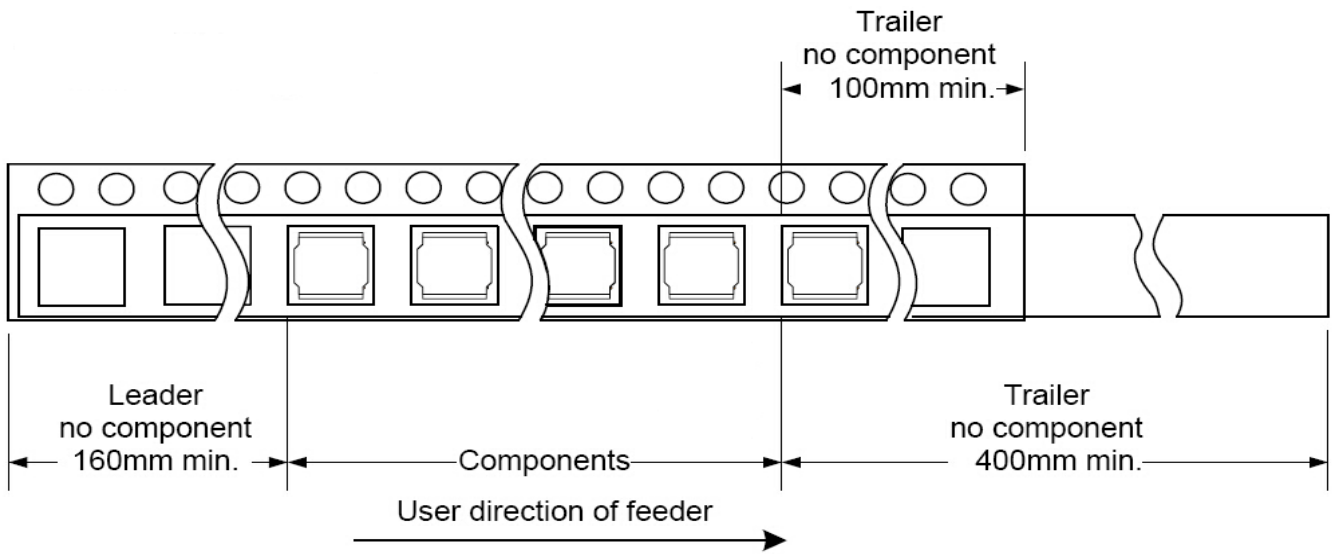

**Cover tape peel off condition**

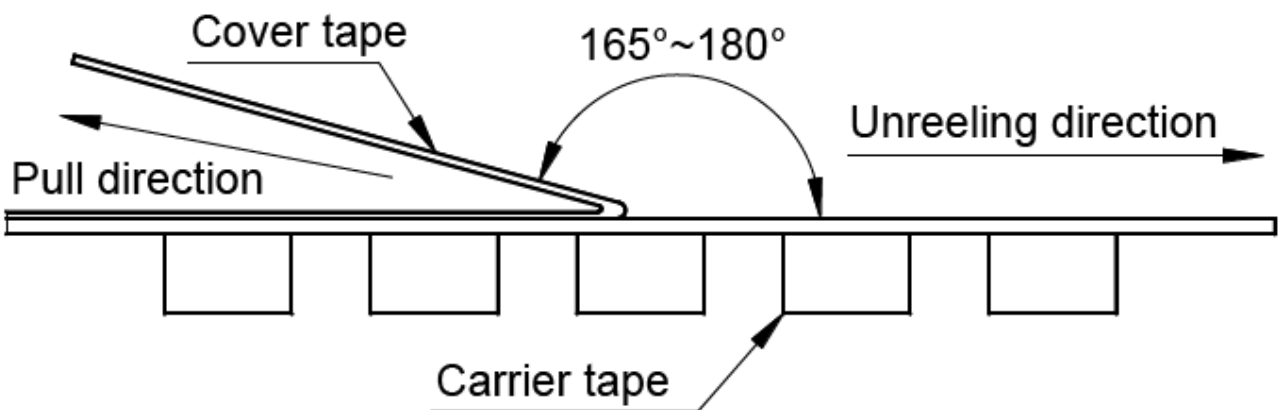

Cover tape peel force shall be 0.1N to 1.3N.

Reference peel speed  $300 \pm 10$ mm/min.