

## ■ Features

- Molding Inductor.
- Low Profile,Low Temp.
- Large Current(Over 15A).
- Customize For Different Need.
- Operating temperature:-40°C ~ +125°C.

## ■ Applications

- General Electronic.
- Video Device,TV,TFT.
- Power Module for PC.
- NB/Lap Top Computer.
- Server,VGA Card/Module.

## ■ Product Identification

$\frac{\text{YSPI}}{(1)} \quad \frac{\square\square\square\square}{(2)} - \frac{\square\square\square}{(3)} \quad \frac{\square}{(4)}$

(1) : Type

(2) : Dimensions

(3) : Inductance value

(4) : Inductance Tolerance : N=±30%,M=±20% , K=±10%

**■ Shapes and Dimensions (Unit: mm)**

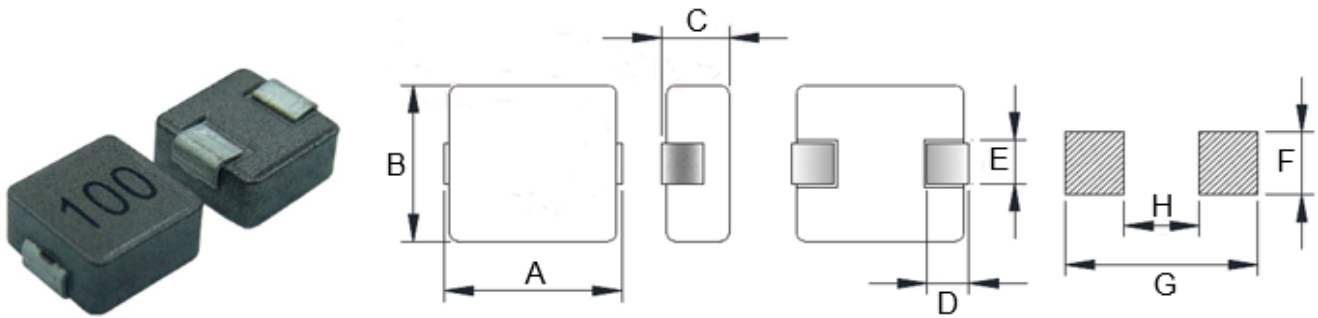

TYPE	A	B	C Max.	D	E Ref.	F Ref.	G Ref.	H Ref.
YSPI0415	4.6±0.2	4.1±0.25	1.5	1.0±0.5	1.5±0.3	2.5	5.2	2.2

**■ YSPI0415 Series**

Part Number	Inductance ( $\mu$ H) @100KHz	DCR Max. ( $m\Omega$ )	Heat Rating Current (A)	Saturation Current (A)
YSPI0415-1R0M	1.0±20%	42	4.0	6.0
YSPI0415-1R5M	1.5±20%	55	3.5	5.0
YSPI0415-3R3M	3.3±20%	132	2.3	3.5
YSPI0415-4R7M	4.7±20%	146	2.0	3.0
YSPI0415-6R8M	6.8±20%	207	1.7	2.3

- ※ The saturation current value is the DC current value having inductance decrease down to 30%.(at 20°C)
- ※ The temperature rise current value is the DC current value having temperature increase up to 40°C. (at 20°C)
- ※ The rated current is the DC current value that satisfies both of current value saturation current value and temperature rise current value.

**■ Taping Dimensions(Unit:mm)**

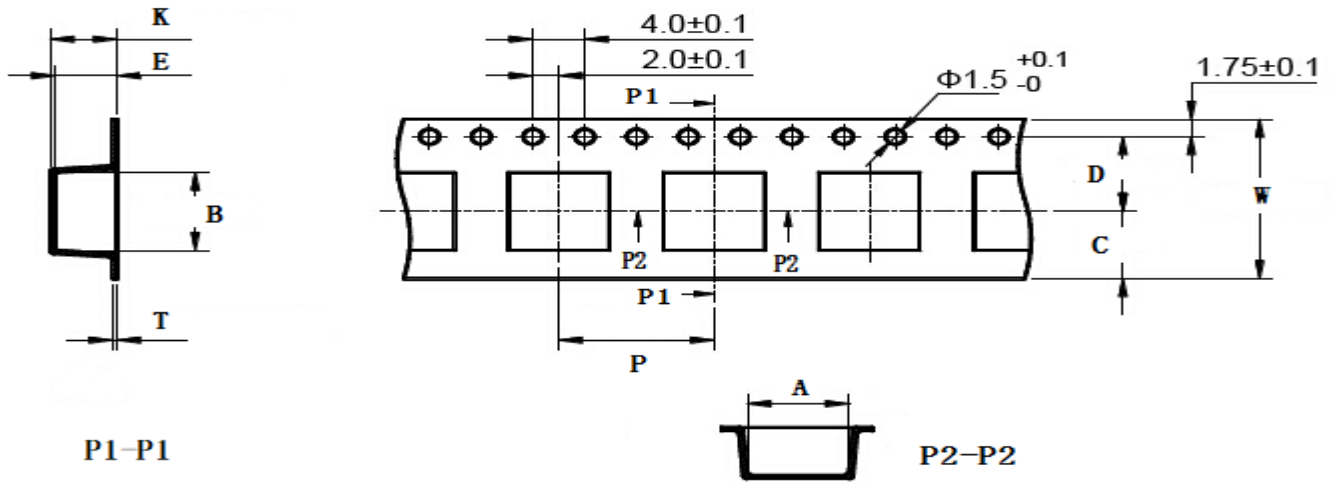

TYPE	W	A	B	C	D	E	P	K Ref	T	MPQ
YSPI0415	12±0.3	4.3±0.1	5.10±0.1	4.75	5.5±0.1	2.1±0.1	8±0.1	2.2	0.30±0.05	4000

**■ Reel Dimensions(Unit:mm)**

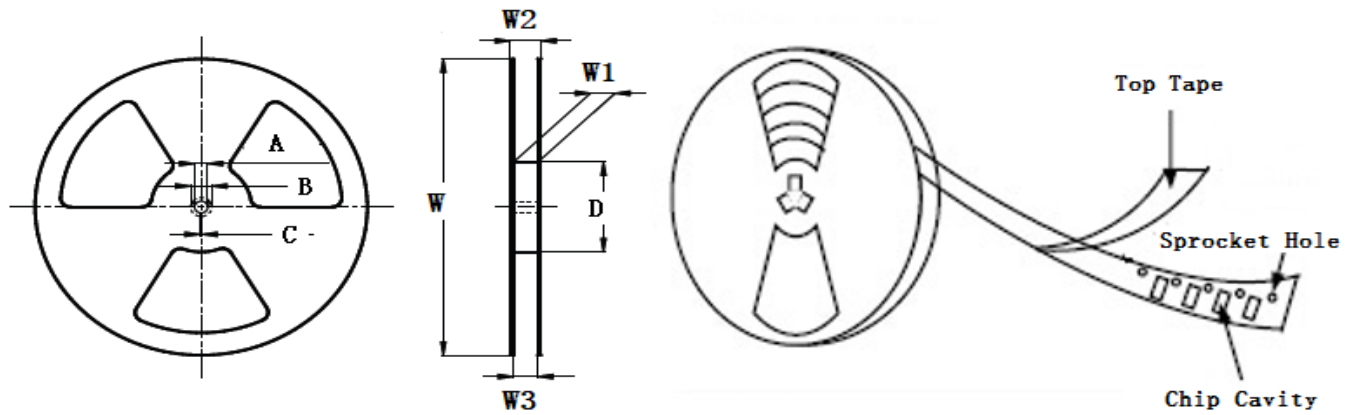

TYPE	W	W1	W2	W3	A	B	C	D
YSPI0415	330±2.0	12.8±1.50	18.4MAX	11.9 Min	13.0±0.50	21.0±0.80	2.0±0.50	100 Min

■ Direction of rolling



■ Cover tape peel off condition

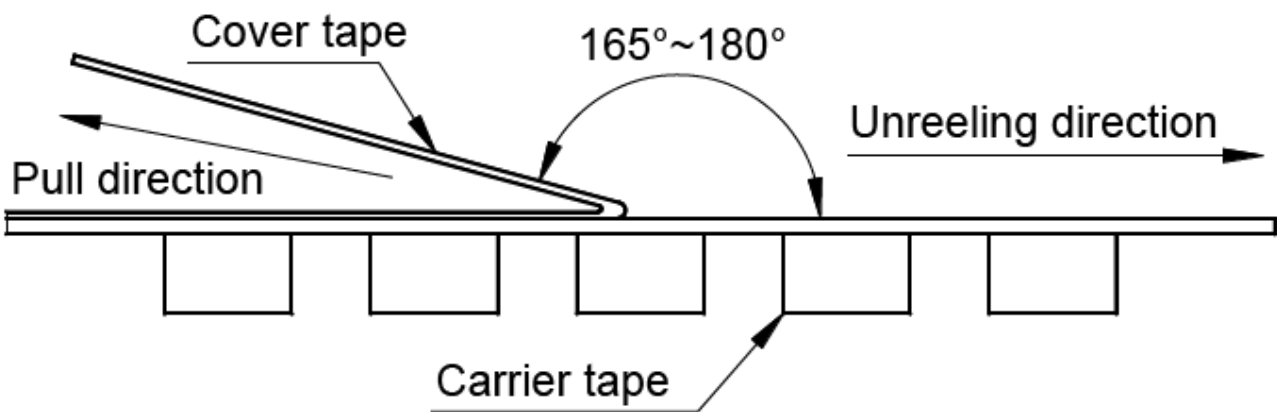

Cover tape peel force shall be 0.1N to 1.3N.

Reference peel speed  $300 \pm 10$ mm/min.