

N-沟道功率 MOS 管/ N-CHANNEL POWER MOSFET

SIF12N70F

- 特点：热阻低 开关速度快 输入阻抗高 符合RoHS规范
- FEATURES: ■LOW THERMAL RESISTANCE ■FAST SWITCHING ■HIGH INPUT RESISTANCE
■RoHS COMPLIANT
- 应用：电子镇流器 电子变压器 开关电源
- APPLICATION: ■ELECTRONIC BALLAST ■ELECTRONIC TRANSFORMER ■SWITCH MODE POWER SUPPLY

●最大额定值 (TC=25°C)

●Absolute Maximum Ratings (Tc=25°C)

TO-220/220FPL/262/263

参数 PARAMETER	符号 SYMBOL	额定值 VALUE	单位 UNIT
漏-源电压 Drain-source Voltage	V_{DS}	700	V
栅-源电压 gate-source Voltage	V_{GS}	± 30	V
漏极电流 Continuous Drain Current TC=25°C	I_D	12	A
漏极电流 Continuous Drain Current TC=100°C	I_D	7.4	A
最大脉冲电流 Drain Current - Pulsed ①	I_{DM}	48	A
耗散功率 Power Dissipation	P_{tot}	TO-220:141	W
		TO-220FPL:55	
		TO-262/263:141	
最高结温 Junction Temperature	T_j	150	°C
存储温度 Storage Temperature	T_{STG}	-55-150	°C
单脉冲雪崩能量 Single Pulse Avalanche Energy②	E_{AS}	600	mJ

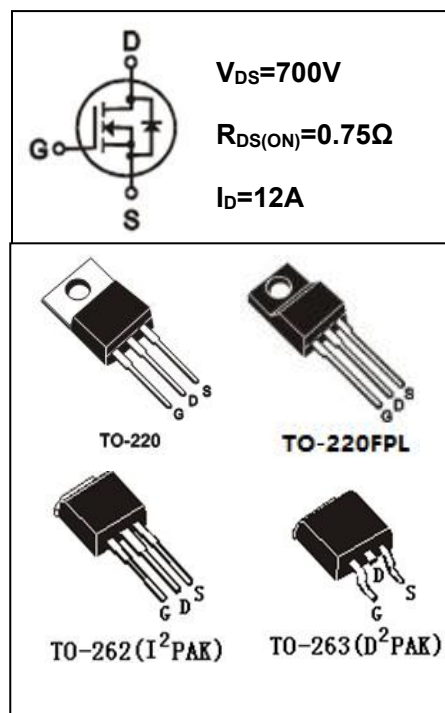

●电特性 (Tc=25°C)

●Electronic Characteristics (Tc=25°C)

参数 PARAMETER	符号 SYMBOL	测试条件 TEST CONDITION	最小值 MIN	典型值 TYP	最大值 MAX	单位 UNIT
漏-源击穿电压 Drain-source Breakdown Voltage	BV_{DSS}	$V_{GS}=0V, I_D=250\mu A$	700			V
击穿电压温度系数 Breakdown Voltage Temperature coefficient	$\Delta BV_{DSS}/\Delta T_j$	$I_D=250\mu A$, Referenced to 25°C		0.65		V/°C
栅极开启电压 Gate Threshold Voltage	$V_{GS(TH)}$	$V_{GS}=V_{DS}, I_D=250\mu A$	2.0		4.0	V
漏-源漏电流 Drain-source Leakage Current	I_{DSS}	$V_{DS}=700V$, $V_{GS}=0V, T_j=25^\circ C$			1	μA
		$V_{DS}=560V$, $V_{GS}=0V, T_j=125^\circ C$			10	μA
跨导 Forward Transconductance	g_{fs}	$V_{DS}=15V, I_D=6.0A$ ③		11		S

●订单信息/ORDERING INFORMATION:

包装形式/PACKING	订货编码/ORDERING CODE	
	普通塑封料 Normal Package Material	无卤塑封料 Halogen Free
TO-220 条管装/TUBE PACKING	SIF12N70F TO-220-TU	SIF12N70F TO-220-TU-HF
TO-220FPL 条管装/TUBE PACKING	SIF12N70F TO-220FPL-TU	SIF12N70F TO-220FPL-TU-HF
TO-262 或 263 条管装/TUBE PACKING	SIF12N70F TO-262-TU 或 SIF12N70F TO-263-TU	SIF12N70F TO-262-TU-HF 或 SIF12N70F TO-263-TU-HF
TO-263 编带装/TAPE & REEL PACKING	SIF12N70F TO-263-TR	SIF12N70F TO-263-TR-HF

N-沟道功率 MOS 管/ N-CHANNEL POWER MOSFET

SIF12N70F

参数 PARAMETER	符号 SYMBOL	测试条件 TEST CONDITION	最小值 MIN	典型值 TYP	最大值 MAX	单位 UNIT
栅极漏电流 Gate-body Leakage Current ($V_{DS} = 0$)	I_{GSS}	$V_{GS} = \pm 30V$			± 100	nA
漏-源导通电阻 Static Drain-source On Resistance	$R_{DS(ON)}$	$V_{GS} = 10V, I_D = 6.0A$ ③		0.75	0.90	Ω
输入电容 Input Capacitance	C_{iss}	$V_{GS} = 0V, V_{DS} = 25V$ $F = 1.0MHz$		1840		pF
输出电容 Output Capacitance	C_{oss}			148		
反向传输电容 Reverse transfer Capacitance	C_{rss}			16		
关断延迟 Turn -Off Delay Time	$T_d(off)$	$V_{DD} = 350V, I_D = 12A$ $R_G = 25\Omega$ ③		155		ns
栅极电荷 Total Gate Charge	Q_g	$I_D = 12A, V_{DS} = 560V$ $V_{GS} = 10V$ ③		40		nC
栅源电荷 Gate-to-Source Charge	Q_{gs}			9.4		nC
栅漏电荷 Gate-to-Drain Charge	Q_{gd}			14		nC
二极管正向电流 Continuous Diode Forward Current	I_S				12	A
二极管正向压降 Diode Forward Voltage	V_{SD}	$T_j = 25^\circ C, I_S = 12A$ $V_{GS} = 0V$ ③			1.4	V
反向恢复时间 Reverse Recovery Time	t_{rr}	$T_j = 25^\circ C, I_f = 12A$ $di/dt = 100A/\mu s$ ③		530		ns
反向恢复电荷 Reverse Recovery Charge	Q_{rr}			4.6		μC

●热特性

●Thermal Characteristics

参数 PARAMETER	符号 SYMBOL	最大值 MAX			单位 UNIT
		TO-220	TO-220FP(L)	TO-262/263	
热阻结-壳 Thermal Resistance Junction-case	R_{thJC}	0.89	2.27	0.89	$^\circ C/W$
热阻结-环境 Thermal Resistance Junction-ambient	R_{thJA}	62.5	62.5	62.5	$^\circ C/W$

注释(Notes):

① 脉冲宽度：以最高节温为限制

Repetitive rating: Pulse width limited by maximum junction temperature

② 初始结温= $25^\circ C$, $V_{DD} = 50V$, $L = 12mH$, $R_G = 25\Omega$, $I_{AS} = 10A$

Starting $T_j = 25^\circ C$, $V_{DD} = 50V$, $L = 12mH$, $R_G = 25\Omega$, $I_{AS} = 10A$

③ 脉冲测试：脉冲宽度 $\leq 300\mu s$ ，占空比 $\leq 2\%$

Pulse Test : Pulse width $\leq 300\mu s$, Duty cycle $\leq 2\%$

N-沟道功率 MOS 管/ N-CHANNEL POWER MOSFET

SIF12N70F

● 特性曲线



图 1 输出特性曲线, Tc=25°C
Fig1 Typical Output Characteristics, Tc=25°C



图 2 导通电阻与漏极电流和栅极电压曲线
Fig2 On-Resistance Vs.Drain Current and Gate Voltage

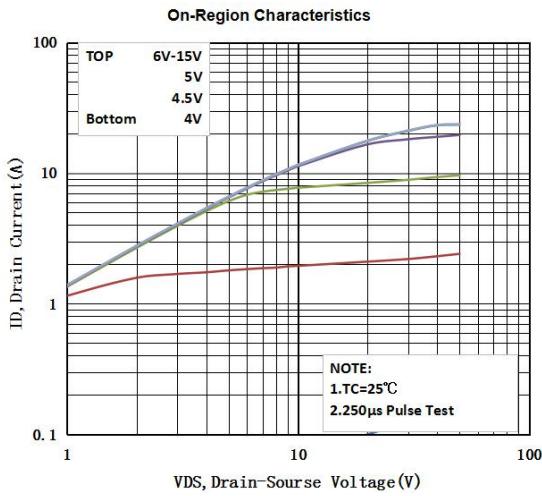

图 3 导通电阻与温度曲线
Fig3 Normalized On-Resistance Vs. Temperature

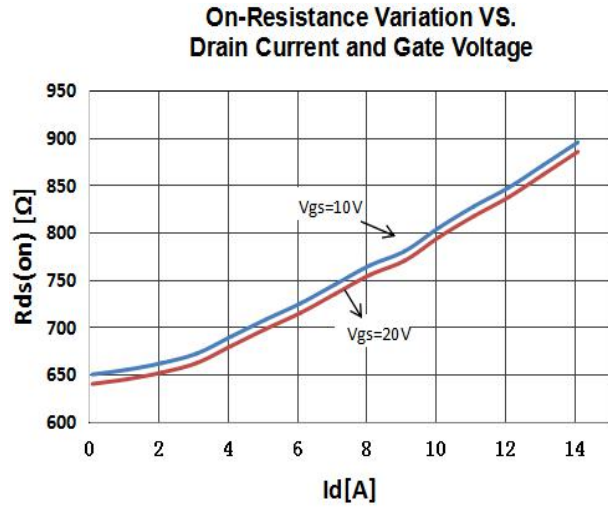

图 4 二极管正向电压曲线
Fig4 Typical Source-Drain Diode Forward Voltage

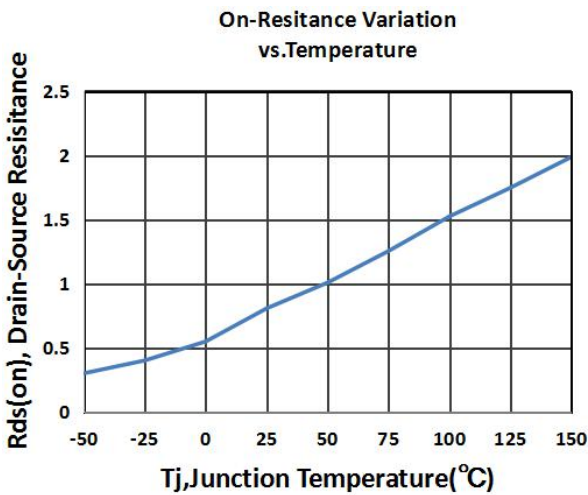

图 5 电容与电压特性曲线
Fig5 Typical Capacitance VS Drain to Source Voltage

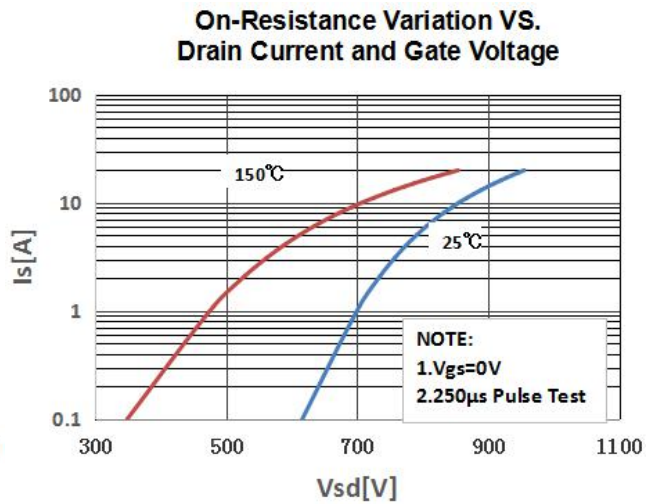

图 6 最大漏极电流与壳温曲线
Fig6 Maximum Drain Current Vs. Case Temperature

N-沟道功率 MOS 管/ N-CHANNEL POWER MOSFET

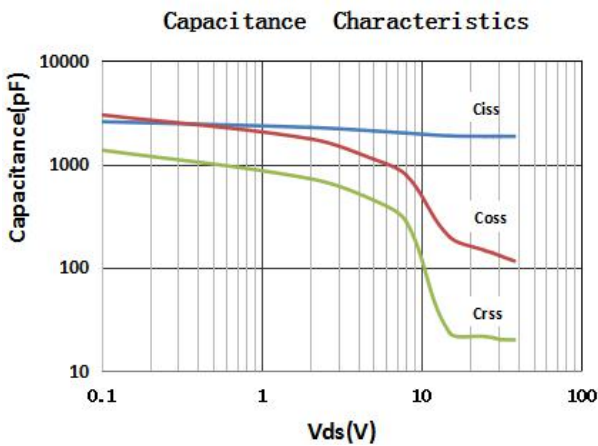
SIF12N70F

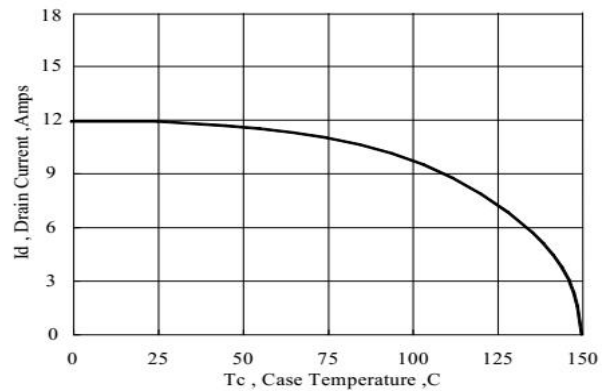

图 7-1 最大安全工作区曲线 (TO-220)

Fig7-1 Maximum Safe Operating Area(TO-220)

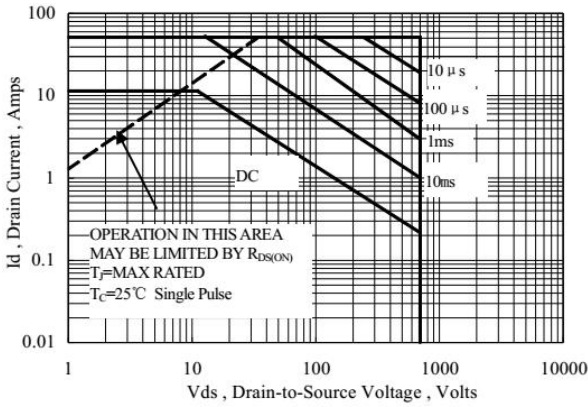

图 7-2 最大安全工作区曲线 (TO-220FPL)

Fig7-2 Maximum Safe Operating Area(TO-220FPL)

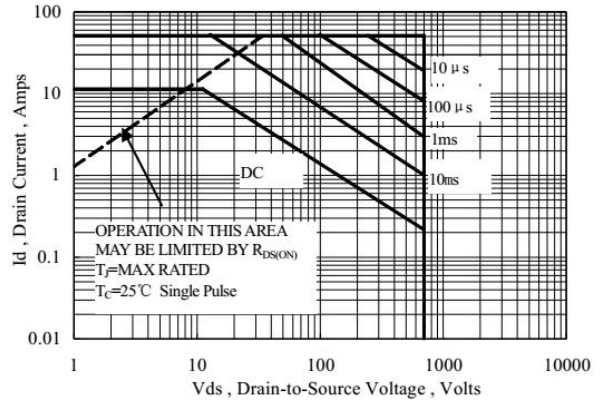

图 7-3 最大安全工作区曲线 (TO-262/263)

Fig7-3 Maximum Safe Operating Area(TO-262/263)

TO-220 封装机械尺寸 TO-220 MECHANICAL DATA

单位：毫米/UNIT: mm

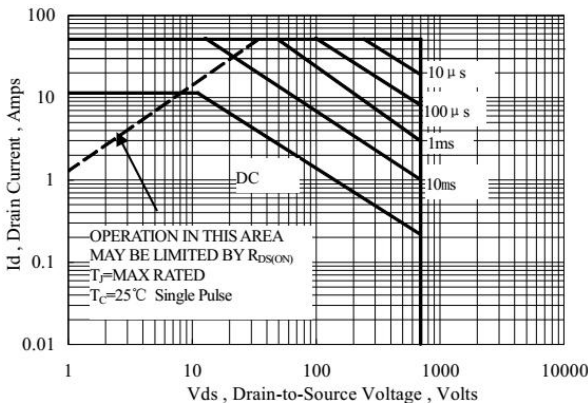
符号 SYMBOL	最小值 min	典型值 nom	最大值 max	符号 SYMBOL	最小值 min	典型值 nom	最大值 max
A	4.00		4.80	E	9.90		10.70
B	1.20		1.50	e		2.54	
B1	1.00		1.40	F	1.10		1.45
b1	0.65		1.00	L	12.50		14.50
c	0.35		0.75	L1	3.00	3.50	4.00
D	15.00		16.50	Q	2.50		3.00
D1	5.90		6.90	Q1	2.00		3.00
				ϕP	3.60		3.90

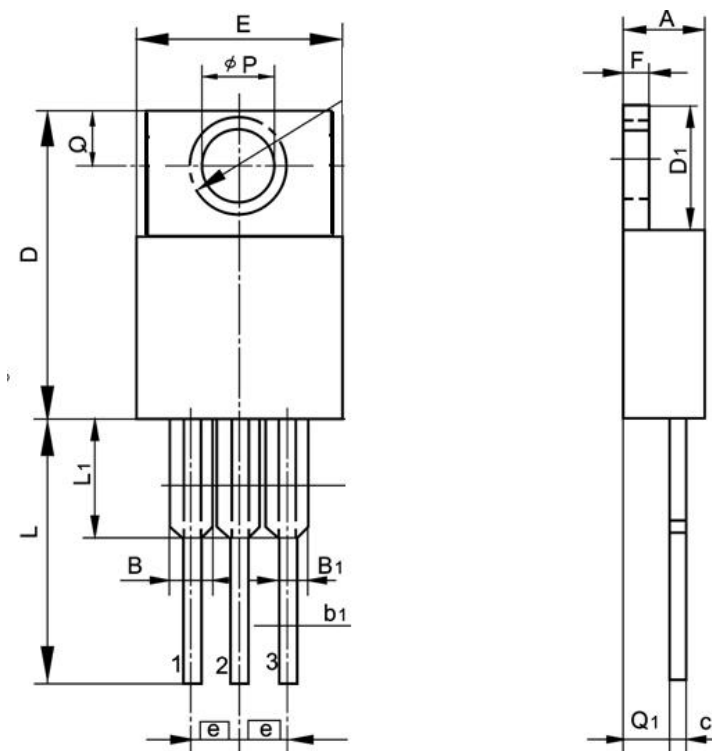

TO-220FPL 封装机械尺寸
TO-220FPL MECHANICAL DATA

单位:毫米/UNIT: mm

符号 SYMBOL	最小值 min	典型值 nom	最大值 max	符号 SYMBOL	最小值 min	典型值 nom	最大值 max
A	9.90		10.36	a	1.08		1.48
B	15.40		16.40	a1	0.70		0.90
B1	3.05		3.55	E	2.34		2.75
C	4.40		5.00	C1	2.25		2.85
c	0.40		0.60	C2	2.45		3.05
b	12.40		13.50	R	2.90		3.35
b1	2.60		3.60				L

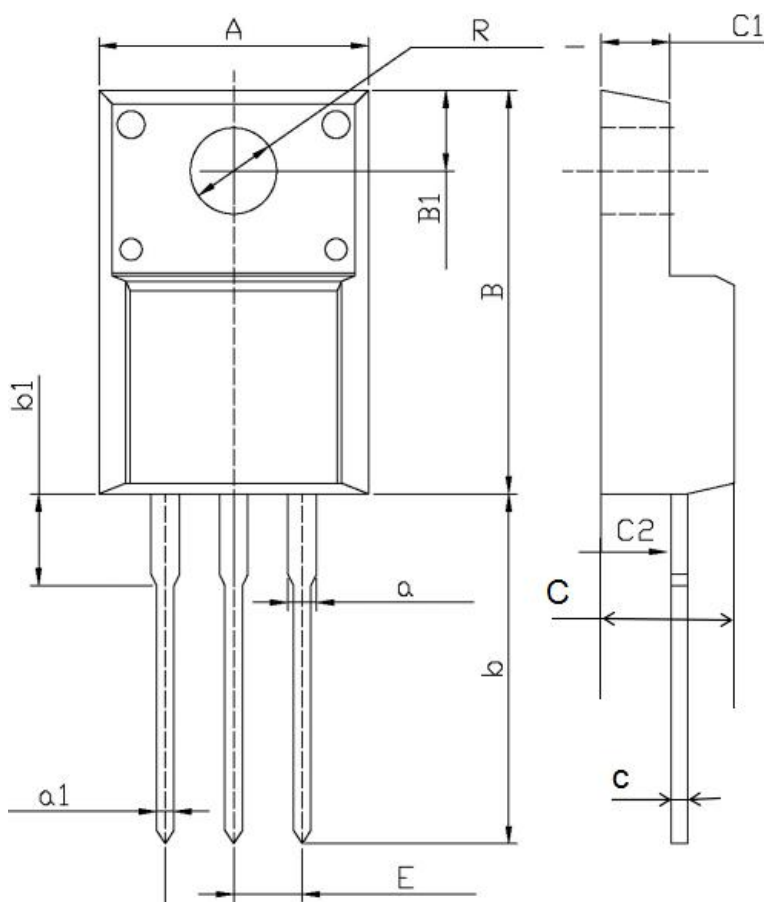

TO-262 封装机械尺寸 TO-262 MECHANICAL DATA

单位：毫米/UNIT: mm

符号 SYMBOL	最小值 min	典型值 nom	最大值 max	符号 SYMBOL	最小值 min	典型值 nom	最大值 max
A	3.80		4.80	e		2.54	
A1	2.00		2.80	e1			5.30
b	0.60		1.00	E	9.90		10.70
b1	1.20		1.40	L	12.50		14.50
c	0.40		0.70	L1	0.80	1.00	1.20
c2	1.10		1.40	L2			1.50
D			9.60				

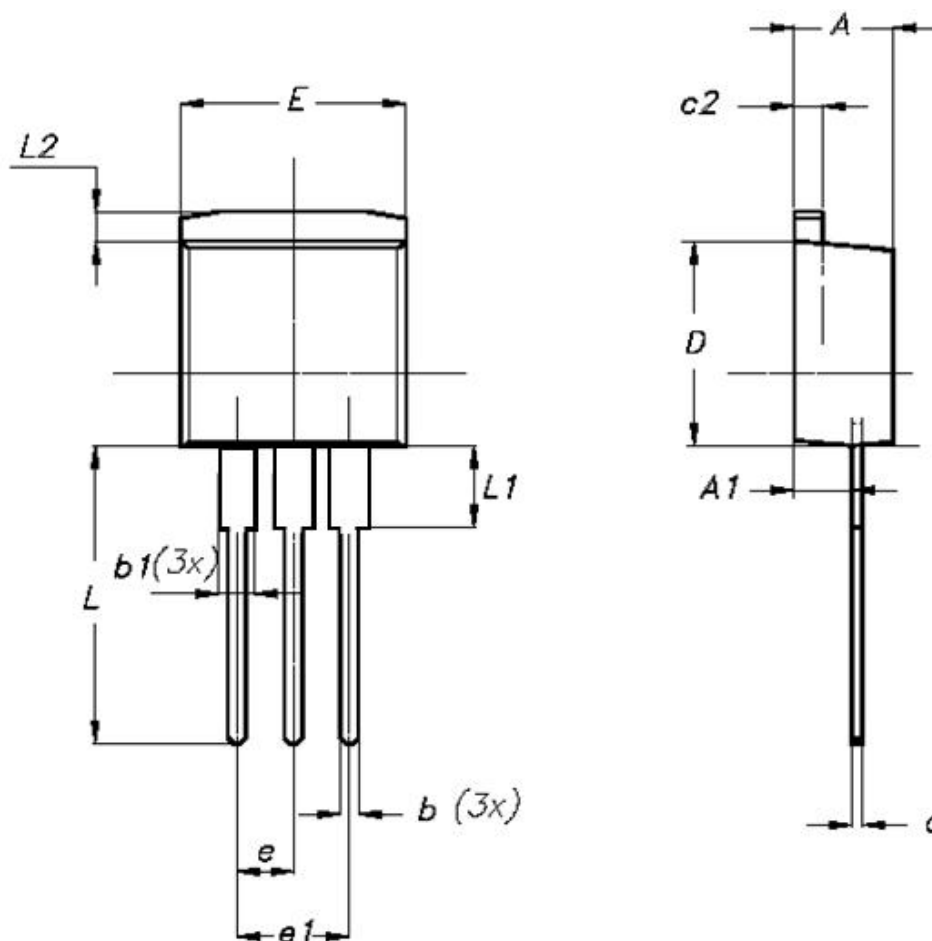

TO-263 封装机械尺寸

TO-263(D2PAK) MECHANICAL DATA

单位：毫米/UNIT: mm

符号 SYMBOL	最小值 min	典型值 nom	最大值 max	符号 SYMBOL	最小值 min	典型值 nom	最大值 max
A	4.42		4.72	E	8.99		9.29
B	1.22		1.32	e1	2.44		2.64
b	0.76		0.86	e2	4.98		5.18
b1	1.22		1.32	L1	15.19		15.79
b2	0.33		0.43	L2	2.29		2.79
C	1.22		1.32	L3	1.30		1.75
D	9.95		10.25				

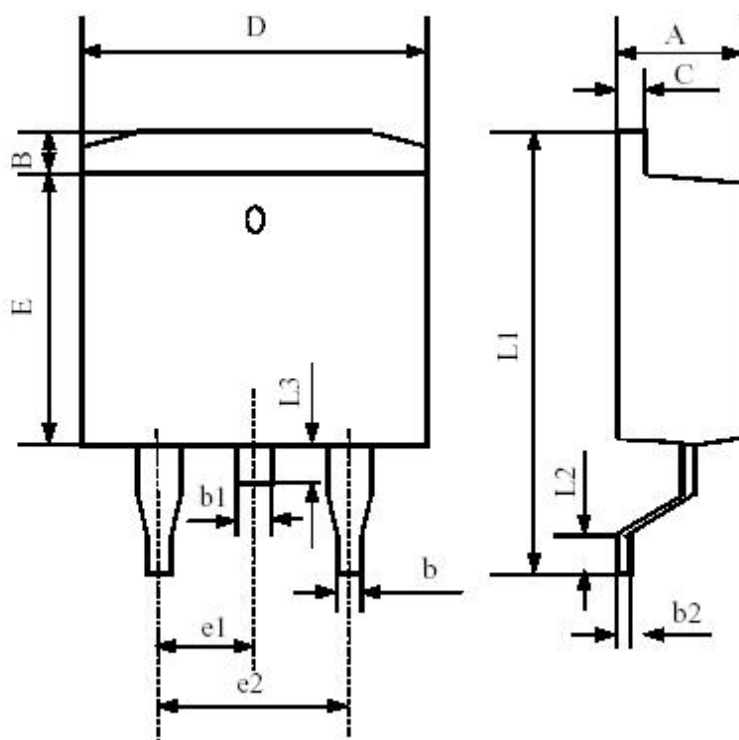

TO-263 编带规格尺寸 TO-263 TAPE AND REEL DATA

单位:毫米/UNIT: mm

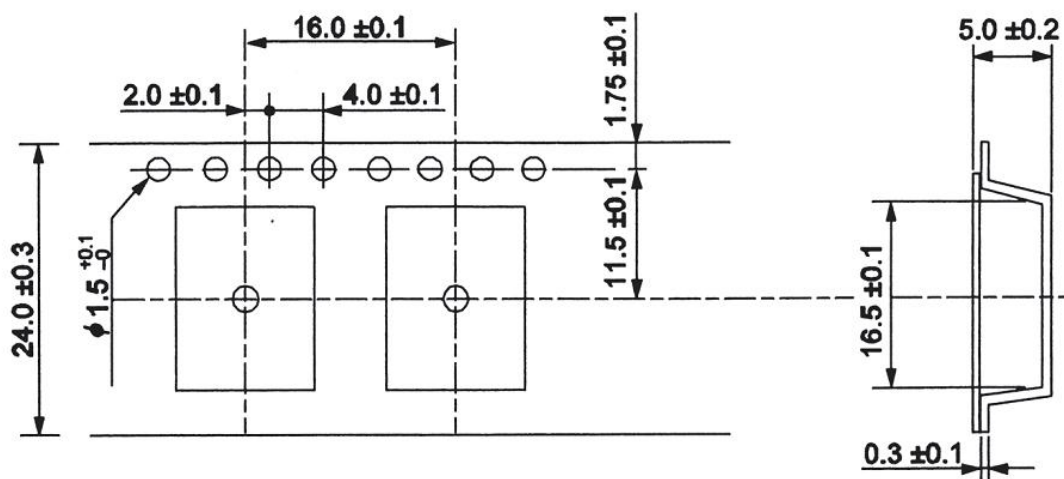

使用供带方向/USER DIRECTION OF FEED

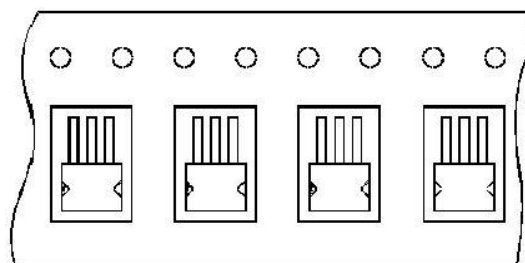

编带器件定位示意图/UNIT ORIENTATION