

PRODUCT NO.	RoHS compliant
DSWB04LHGETB	

REV.	ECN NO.	DR	DATE

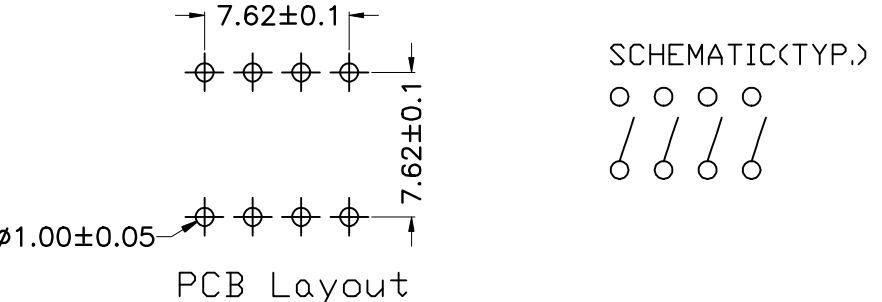
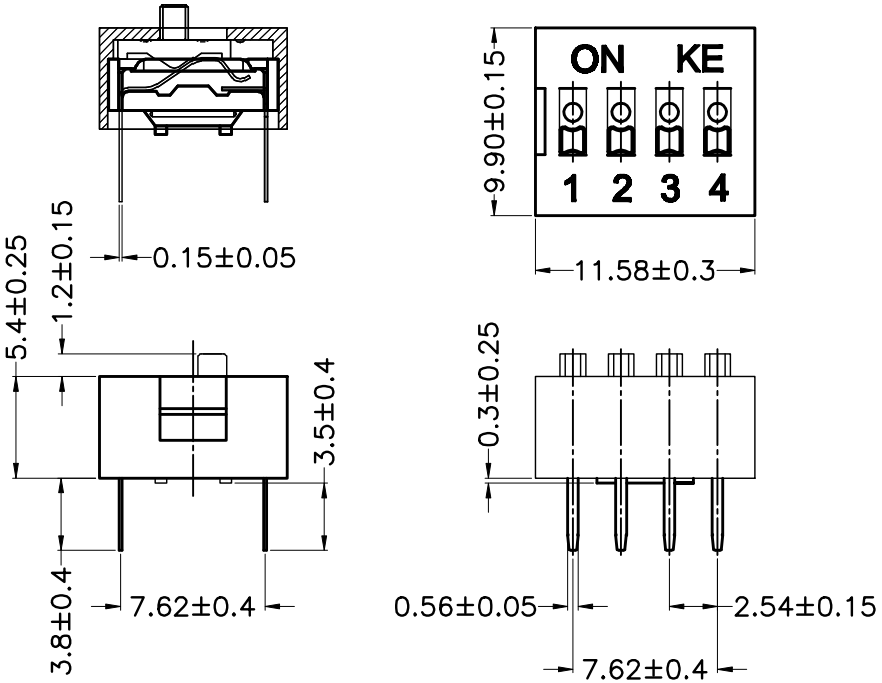

Note:

- 1. All dimensions are in millimeters.
- 2. General tolerance: ±0.2mm.
- 3. Material:
 - Base: UL94V-0 PBT Thermoplastic (Black).
 - Cover: UL94V-0 PBT Thermoplastic (Black/Red/Blue).
 - Actuators: UL94V-0 PBT Thermoplastic (White).
 - Contact plating: Gold plating over nickel.
 - Pitting material: Epoxy.
- 4. Electrical
 - Electrical: 2000 Operations per switch 24/VDC, 25mA.
 - Non-Switching Rating: 100mA, 50/VDC.
 - Switching Rating: 25mA, 24/VDC.
 - Contact Resistance: 100 mΩ Max. at initial.
- 5. Mechanical
 - Mechanical life: 2000 Operations per switch.
 - Stroke: 2.0mm.
 - Operation Temp: -20°C to 70°C.
 - Storage Temp: -40°C to 85°C.

6. PART NUMBER DESCRIPTION:

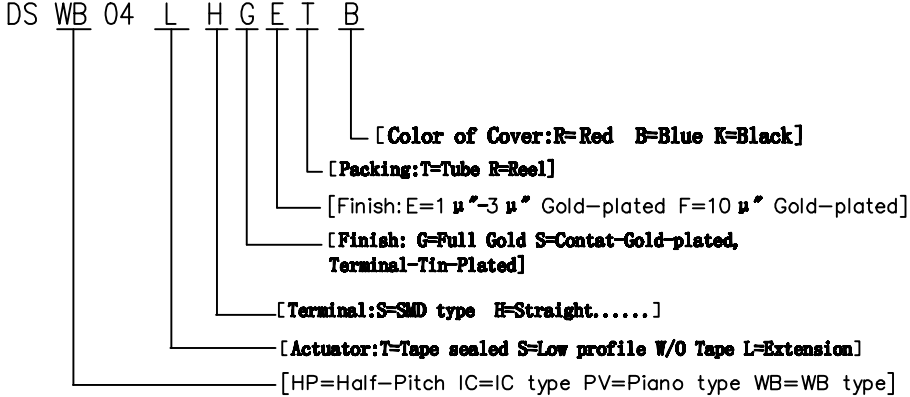

- 注意:**
- 1. 波峰焊: 推荐焊锡温度在270°C ± 5°C, 浸锡时间为5~6秒钟。
 - 2. 手工焊: 使用30瓦烙铁控制温度在320°C, 焊接时间大约2~3秒钟。
 - 3. 拨柄位置: 产品焊接时, 请将产品的拨柄置于OFF端, 能给予产品更好的接触性能。
 - 4. 清洗过程: 清洗使用超声波方式, 能给予更好的效果。

TOLERANCE UNLESS OTHERWISE SPECIFIED		INSPECTION COPY	
LINER	ANGLES		
.0 ± 0.30	0. ± 1'	PROJECTION	TITLE
.00 ± 0.20	.0 ± 0.5'		BY DSWB SERIES PITCH 2.54mm
.000 ± 0.10	.00 ±		PRODUCT FAMILY DSWB SERIES
DESIGN	LU ER XIN	2013/07/02	PRAT NO. DSWB04LHGETB
DRAWING			FILE NO. DSWB04LHGETB-A
CHECK			SIZE UNIT SCALE SHEET REV.
APPRO.			A4 mm FIT 1 OF 1 A