

PRODUCT NO.	RoHS compliant
DSWB03LHGETB	

REV.	ECN NO.	DR	DATE

**Note:**

- All dimensions are in millimeters.
- General tolerance:  $\pm 0.2\text{mm}$ .
- Material:
  - Base: UL94V-0 PBT Thermoplastic (Black).
  - Cover: UL94V-0 PBT Thermoplastic (Black/Red/Blue).
  - Actuators: UL94V-0 PBT Thermoplastic (White).
  - Contact plating: Gold plating over nickel.
  - Pitting material: Epoxy.
- Electrical
  - Electrical: 2000 Operations per switch 24/VDC, 25mA.
  - Non-Switching Rating: 100mA, 50/VDC.
  - Switching Rating: 25mA, 24/VDC.
  - Contact Resistance: 100 m $\Omega$  Max. at initial.
- Mechanical
  - Mechanical life: 2000 Operations per switch.
  - Stroke: 2.0mm.
  - Operation Temp: -20°C to 70°C.
  - Storage Temp: -40°C to 85°C.

**6. PART NUMBER DESCRIPTION:**

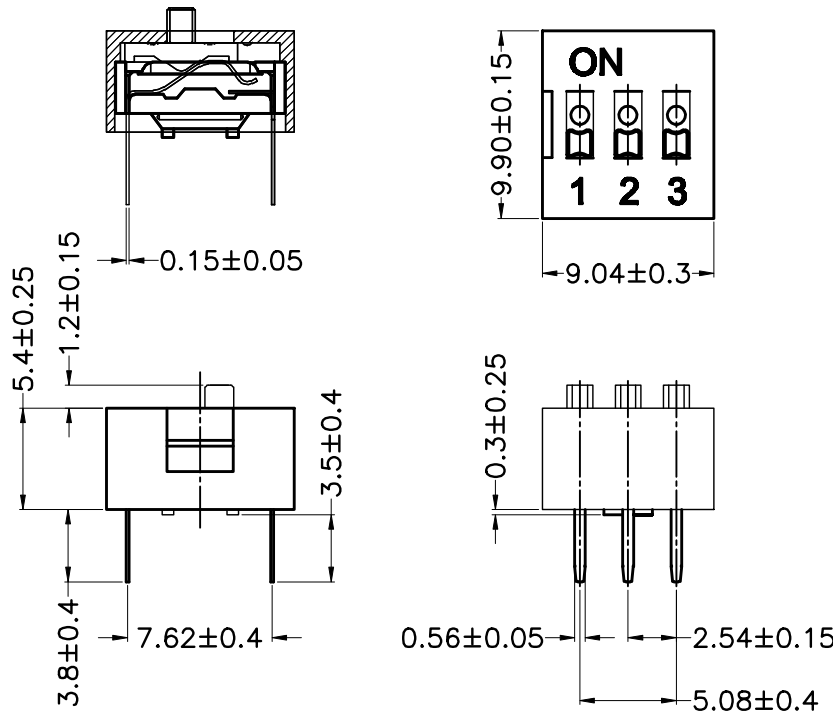
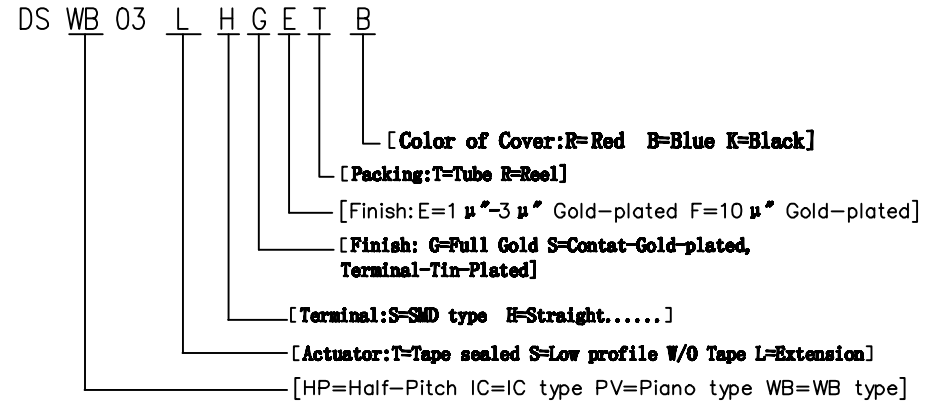

SCHMATIC (TYP.)

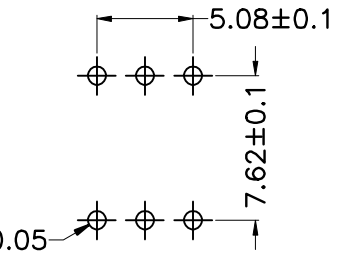
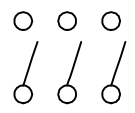

PCB Layout

**注意:**

- 波峰焊: 推荐焊锡温度在  $270^\circ\text{C} \pm 5^\circ\text{C}$ , 浸锡时间为 5~6 秒钟。
- 手工焊: 使用 30 瓦烙铁控制温度在  $320^\circ\text{C}$ , 焊接时间大约 2~3 秒钟。
- 拨柄位置: 产品焊接时, 请将产品的拨柄置于 OFF 端, 能给予产品更好的接触性能。
- 清洗过程: 清洗使用超声波方式, 能给予更好的效果。

TOLERANCE UNLESS OTHERWISE SPECIFIED		INSPECTION COPY	东莞市广誉实业有限公司 DongGuan Kingtek Industrial Co., Ltd.
LINER	ANGLES	PROJECTION	
.0 $\pm$ 0.30	0. $\pm$ 1'		TITLE
.00 $\pm$ 0.20	.0 $\pm$ 0.5'		BY DSWB SERIES PITCH 2.54mm
.000 $\pm$ 0.10	.00 $\pm$		PRODUCT FAMILY DSWB SERIES
DESIGN LU ER XIN	2013/07/02		PRAT NO. DSWB03LHGETB
DRAWING			FILE NO. DSWB03LHGETB-A
CHECK			SIZE A4
APPRO.			UNIT mm
			SCALE FIT
			SHEET 1 OF 1
			REV. A