

SEBT3904U
NPN switching transistor

Features

- Low current (max. 100 mA).
- Low voltage (max. 40 V).

Applications

- Telephony and professional communication equipment.

DESCRIPTION

- NPN switching transistor in a SOT323 plastic package
- PNP complement: SEBT3906U.

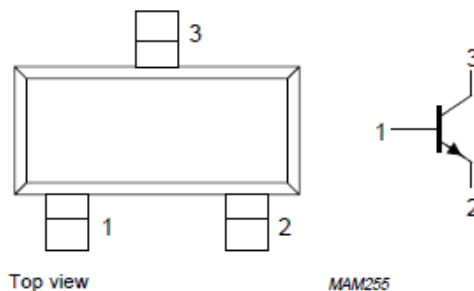

Fig.1 Simplified outline (SOT323) and symbol.

Absolute maximum ratings (Ta=25°C)

Parameter	Symbol	CONDITIO NS	MIN.	MAX.	Unit
collector-base voltage	V_{CBO}	open emitter	–	60	V
collector-emitter voltage	V_{CEO}	open base	–	40	V
emitter-base voltage	V_{EBO}	open collector	–	6	V
collector current DC	I_C		–	200	mA
peak collector current	I_{CM}		–	200	mA
peak base current	I_{BM}		–	100	mA
total power dissipation	P_{tot}	$T_{amb} \leq 25$ ° C; note 1	–	250	mW
storage temperature	T_{stg}		–65	+150	°C
junction temperature	T_j		–	150	°C
operating ambient temperature	T_{amb}		–65	+150	°C

Electrical characteristics (Ta=25°C)

Parameter	Symbol	CONDITIONS	Min.	Max.	Unit
collector cut-off current	I_{CBO}	$I_E = 0; V_{CB} = 30$ V	-	50	nA
emitter cut-off current	I_{EBO}	$I_C = 0; V_{EB} = 6$ V	-	50	nA

SEBT3904U

DC current gain	h_{FE}	$V_{CE} = 1 \text{ V}$; note 1; Fig.2 $I_C = 0.1 \text{ mA}$	60	-	
		$I_C = 1 \text{ mA}$	80	-	
		$I_C = 10 \text{ mA}$	100	300	
		$I_C = 50 \text{ mA}$	60	-	
		$I_C = 100 \text{ mA}$	30	-	
collector-emitter saturation voltage	V_{CEsat}	$I_C = 10 \text{ mA}$; $I_B = 1 \text{ mA}$	-	200	mV
		$I_C = 50 \text{ mA}$; $I_B = 5 \text{ mA}$	-	200	mV
base-emitter saturation voltage	V_{BEsat}	$I_C = 10 \text{ mA}$; $I_B = 1 \text{ mA}$	650	850	mV
		$I_C = 50 \text{ mA}$; $I_B = 5 \text{ mA}$	-	950	mV
collector capacitance	C_c	$I_E = i_e = 0$; $V_{CB} = 5 \text{ V}$; $f = 1 \text{ MHz}$	-	4	pF
emitter capacitance	C_e	$I_C = i_c = 0$; $V_{BE} = 500 \text{ mV}$; $f = 1 \text{ MHz}$	-	8	pF
transition frequency	f_T	$I_C = 10 \text{ mA}$; $V_{CE} = 20 \text{ V}$; $f = 100 \text{ MHz}$	300	-	MHz
noise figure	F	$I_C = 100 \text{ mA}$; $V_{CE} = 5 \text{ V}$; $R_S = 1 \text{ kW}$; $f = 10 \text{ Hz}$ to 15.7 kHz	-	5	dB

Switching times (between 10% and 90% levels); (see Fig.3)

t_{on}	turn-on time	$I_{Con} = 10 \text{ mA}$; $I_{Bon} = 1 \text{ mA}$; $I_{Boff} = -1 \text{ mA}$	-	65	ns
t_d	delay time		-	35	ns
t_r	rise time		-	35	ns
t_{off}	turn-off time		-	240	ns
t_s	storage time		-	200	ns
t_f	fall time		-	50	ns

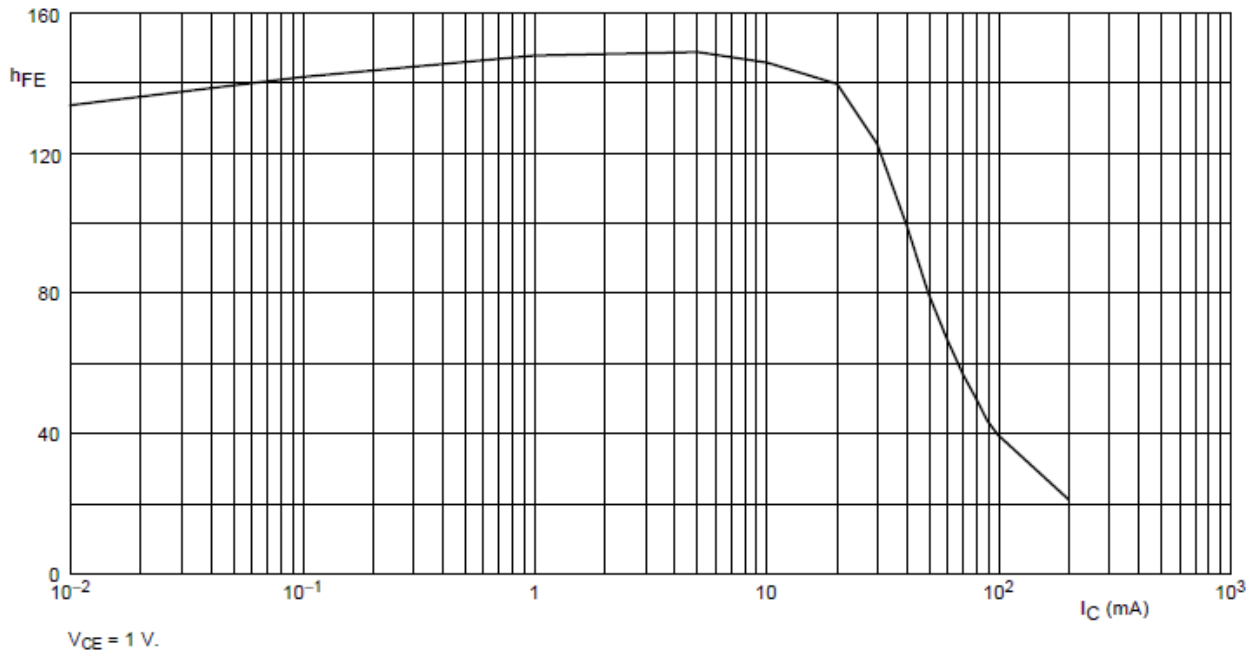
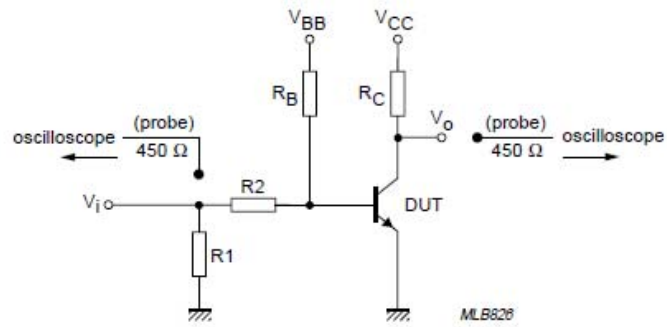

Fig.2 DC current gain; typical values.



$V_i = 5 \text{ V; } T = 500 \mu\text{s; } t_p = 10 \mu\text{s; } t_r = t_f \leq 3 \text{ ns.}$
 $R_1 = 56 \Omega; R_2 = 2.5 \text{ k}\Omega; R_B = 3.9 \text{ k}\Omega; R_C = 270 \Omega.$
 $V_{BB} = -1.9 \text{ V; } V_{CC} = 3 \text{ V.}$
 Oscilloscope: input impedance $Z_i = 50 \Omega.$

Fig.3 Test circuit for switching times.

SEBT3904U

SOT-323 PACKAGE OUTLINE

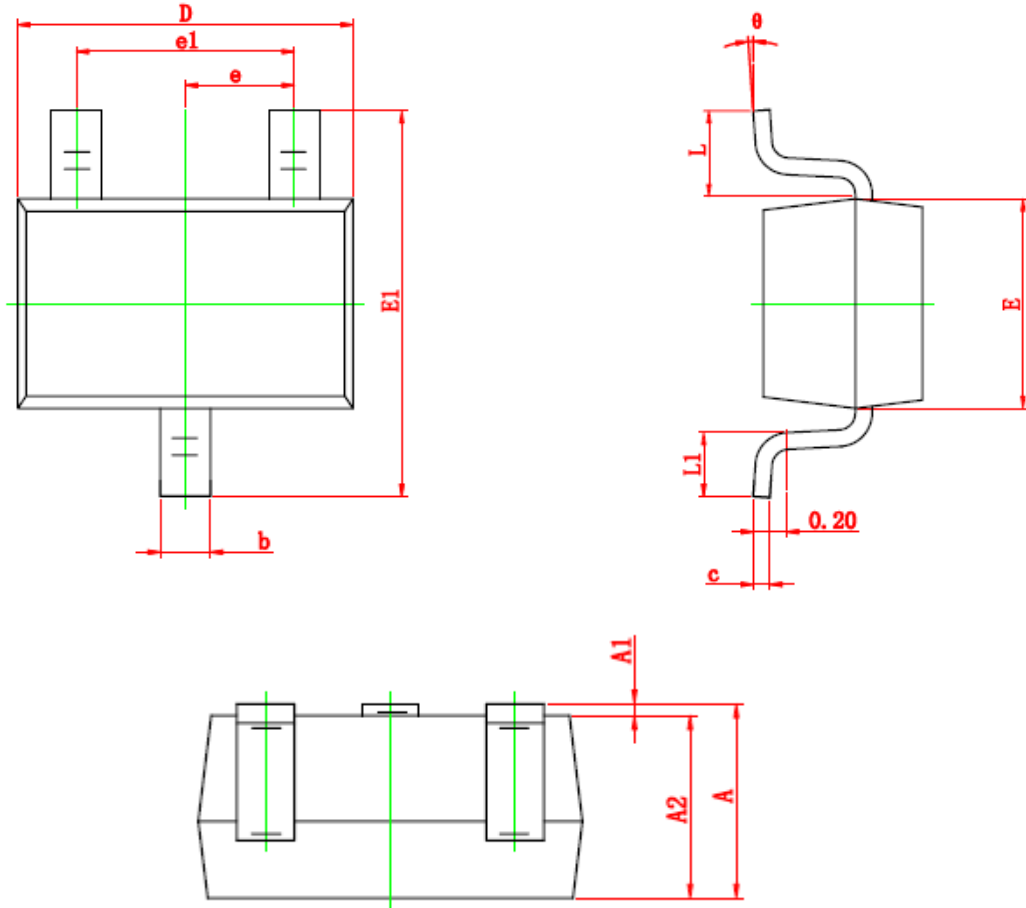

Symbol	Dimensions In Millimeters		Dimensions In Inches	
	Min	Max	Min	Max
A	0.900	1.100	0.035	0.043
A1	0.000	0.100	0.000	0.004
A2	0.900	1.000	0.035	0.039
b	0.200	0.400	0.008	0.016
c	0.080	0.150	0.003	0.006
D	2.000	2.200	0.079	0.087
E	1.150	1.350	0.045	0.053
E1	2.150	2.450	0.085	0.096
e	0.650 TYP		0.026 TYP	
e1	1.200	1.400	0.047	0.055
L	0.525 REF		0.021 REF	
L1	0.260	0.460	0.010	0.018
θ	0°	8°	0°	8°

The SINO-IC logo is a registered trademark of ShangHai Sino-IC Microelectronics Co., Ltd.

© 2005 SINO-IC – Printed in China – All rights reserved.

SHANGHAI SINO-IC MICROELECTRONICS CO., LTD

Add: Building 3, Room 3401-03, No.200 Zhangheng Road, ZhangJiang Hi-Tech Park, Pudong,
Shanghai 201203, China

Phone: +86-21-33932402 33932403 33932405 33933508 33933608

Fax: +86-21-33932401

Email: szrxw002@126.com

Website: <http://www.sino-ic.net>