

36V, 5A Monolithic Step-Down Switching Regulator

1 Features

- 5A continuous output current capability
- 4.5V to 36V wide operating input range
- 2V to 32 V wide output range
- Integrated 40V, 11mΩ high side and 40V, 13mΩ low side power MOSFET switches
- Dynamical programming of input current, Output current and Output voltage using PWM signal or analog signal
- Adjustable Switching Frequency using resistor
- Frequency dithering for good EMI performance
- Comprehensive protection features including Output Short Protection (OSP), Cycle-by-Cycle input and output Peak Current Limit, thermal regulation, thermal shutdown, input UVLO, input OVP, output OVP etc.
- Input or Output Average Current Limiting with stable CC loop
- 5V/55mA low I_q LDO to power system MCU
- QFN5x5-32 Package

3 Description

PL84051 integrates a high efficiency synchronous step-down switching regulator, which includes a 40V, 11mΩ high side and a 40V, 13mΩ low side MOSFETs to provide 5A continuous load current over 4.5V to 36V wide operating input voltage.

PL84051 employs Constant ON time control. The switching frequency could be set to 150kHz, 300kHz, 600kHz or 1200kHz based on different resistor value between **FREQ** pin and **GND** pin. The device also features a programmable soft-start function and offers all kinds of protection features including cycle-by-cycle current limiting, input under voltage lockout (UVLO), output over voltage protection (OVP), input Over Voltage Protection, thermal shutdown and output short protection etc.

PL84051 provides voltage control loop, constant current loop, and thermal regulation loop.

2 Applications

- Automotive Start-Stop Systems
- Power Bank / Car Charger
- Industrial PC Power Supplies
- USB Power Delivery

4 Typical Application Schematic

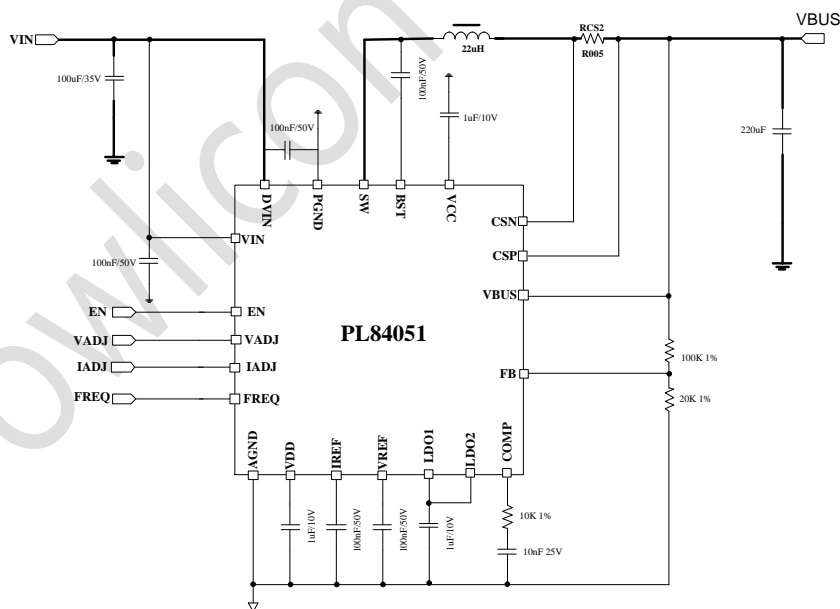

Fig. 1 Application Schematic

5 Pin Configuration and Functions

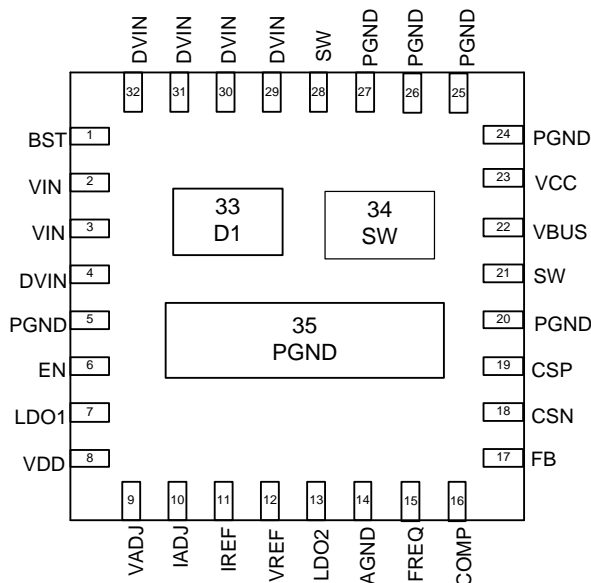

Fig. 2 Pin-Function (QFN5X5-32)

Pin		Description
Number	Name	
1	BST	Boost pin for high side MOSFET driver.
2,3	VIN	Input Voltage.
4, 29, 30, 31, 32	DVIN	Power node of VIN.
5, 20, 24, 25, 26, 27	PGND	Power ground.
6	EN	Logic High will enable the converter. Logic Low will disable the whole PL84051 except LDO2. Only LDO2 is working to power system MCU when EN is low.
7	LDO1	Connect LDO1 to LDO2.
8	VDD	5.4V power supply for PL84051 control core.
9	VADJ	Connect a 0-2V analog voltage or a PWM signal to program voltage reference on VREF pin. Connect this pin to VDD will force VREF to constant 2V.
10	IADJ	Connect a 0-2V analog voltage or a PWM signal to program voltage reference on IREF pin. Connect this pin to VDD will force IREF to 2V.
11	IREF	Reference voltage for input and output current limiting loop.
12	VREF	Voltage reference for voltage control loop
13	LDO2	Low quiescent current 5V/55mA LDO. Directly powered from VIN pin. LDO can be used as power supply for application processor such as MCU. When EN is low, only this LDO will be active to power MCU and keep low quiescent current for the whole system.
14	AGND	Analog ground. Connect PGND and AGND together at the thermal pad under IC.
15	FREQ	Connect to GND to set the switching frequency at 150kHz. Connect this pin to VDD to set switching frequency at 300kHz. Connect to a resistor divider between VDD and GND to set frequency to 600k and 1200k Hz.
16	COMP	Error Amplifier output.

17	FB	VBUS voltage feedback. Connect a resistor divider between VBUS and GND to FB to program VBUS voltage.
18	CSN	The minus input of output current sense.
19	CSP	The positive input of output current sense.
21、 28	SW	Connect this pin to the Switching point of the power stage.
22	VBUS	Connect to the VBUS rail.
23	VCC	6.6V power supply for high side and low side driver.

6 Device Marking Information

Part Number	Order Information	Package	Package Qty	Top Marking
PL84051	PL84051IQN32	QFN5*5-32	5000	84051 RAAYMD

PL84051: Part Number

RAAYMD: RAA: LOT NO.; YMD: Package Date

7 Specifications

7.1 Absolute Maximum Ratings^(Note1)

PARAMETER	MIN	MAX	Unit
VIN,VDIN, VBUS, CSN, CSP, SW	-0.3	40	V
BST to SW	-0.3	7	
VCC to GND	-0.3	7	
CSP to CSN	-0.3	0.6	
VBUS to CSP, CSN	-0.3	0.6	
Other Pins to GND	-0.3	6	

7.2 Handling Ratings

PARAMETER	DEFINITION	MIN	MAX	UNIT
T _{ST}	Storage Temperature Range	-65	150	°C
T _J	Junction Temperature		+150	°C
T _L	Lead Temperature		+260	°C
V _{ESD}	HBM Human body model		2	kV

7.3 Recommended Operating Conditions^(Note 2)

	PARAMETER	MIN	MAX	Unit
Input Voltages	VIN, VDIN , VBUS	3.6	32	V
Temperature	Operating junction temperature range, T _J	-40	+125	°C

7.4 Thermal Information^(Note 3)

Symbol	Description	QFN5X5-32	Unit
θ_{JA}	Junction to ambient thermal resistance	44	°C/W
θ_{JC}	Junction to case thermal resistance	9	

Notes:

- 1) Exceeding these ratings may damage the device.
- 2) The device function is not guaranteed outside of the recommended operating conditions.
- 3) Measured on approximately 1" square of 1 oz copper.

7.5 Electrical Characteristics (Typical at VIN = 12V, T_J = 25°C, unless otherwise noted.)

Supply voltages	PARAMETER	CONDITION	MIN	TYP	MAX	UNIT
V _{IN}	Input voltage		4.5		32	V
I _{Q_VIN}	V _{IN} Shutdown Current	EN=0V, V _{IN} =7.2V		15		µA
	V _{IN} Supply Current	No Switching, FB=2.1V		1000		µA
V _{BUS}	Bus line voltage		2		30	V
I _{Q_VBUS}	V _{BUS} Shutdown Current	EN=0V, V _{BUS} =7.2V		15		µA
	V _{BUS} Supply Current	No Switching		1200		µA
V _{VCC}	Driver power supply voltage	V _{IN} =15V		6.6		V
V _{VDD}	Control core power supply voltage	V _{IN} =15V		5.4		V
V _{LDO}	LDO output voltage	V _{IN} =15V		5		V
I _{LDO}	LDO output current	V _{LDO} =5V			55	mA
UVLO/EN						
V _{IN_UV}	V _{IN} UVLO Rising			3.5		V
	UVLO Hysteresis			300		mV
V _{BUS_UV}	V _{BUS} UVLO Rising			3.5		V
	UVLO Hysteresis			300		mV
V _{EN_UV}	Operation Threshold		1.1	1.2	1.3	V
	Hysteresis			200		mV
VREF						
V _{VREF_Dischg}	VREF voltage in discharge mode	V _{ADJ} connected to V _{DD}		2		V
V _{VREF_chg}	VREF voltage in charge mode	V _{ADJ} connected to V _{DD}		1.8		V
Control loop						
V _{FB}	V _{FB} regulation voltage in discharging mode	FB voltage		2		V
G _{mEA}	Error amplifier gm			450		µS
I _{SINK}	COMP sink/source current	V _{FB} =V _{VREF} +100mV		15		µA
I _{SOURCE}	COMP source current	V _{FB} =V _{VREF} -100mV		20		µA
I _{FB}	FB bias current	FB2 in regulation			100	nA
Frequency						
F _{SW}	Switching Frequency	FREQ 0-0.4V, short FREQ pin to GND.		150		KHz
		FREQ 1.8-5.4V, short FREQ pin to V _{DD} .		300		KHz
		FREQ 0.4-0.85V		600		KHz
		FREQ 0.85-1.8V		1200		KHz
Current Limit						
I _{CCLIM_BUS}	Bus average current Limit, V _{CSP2} - V _{CSP2}	Discharging mode		40		mV
Output Protection						
V _{OVP}	Output over voltage threshold			110		%
V _{UVP}	Output under voltage threshold			50		%
V_{ADJ}, I_{ADJ}						
V _{TH_VADJ} (Note 4)	VPWM low voltage				0.4	V
	VPWM high voltage		2.5			V
V _{TH_IADJ} (Note 4)	IPWM low voltage				0.4	V
	IPWM high voltage		2.5			V
T _{SD} (Note 4)	Thermal Shutdown Threshold			150		°C
T _{HYS} (Note 4)	Thermal Shutdown Hysteresis			20		°C

Notes:

4) Guaranteed by design.

8 Typical Characteristics

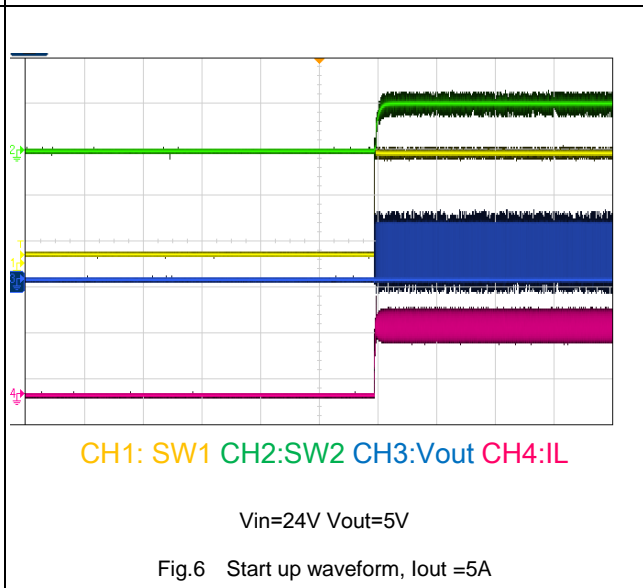
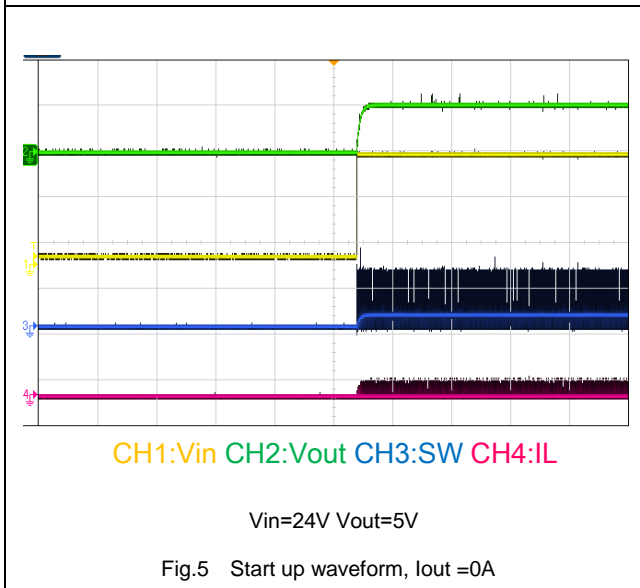
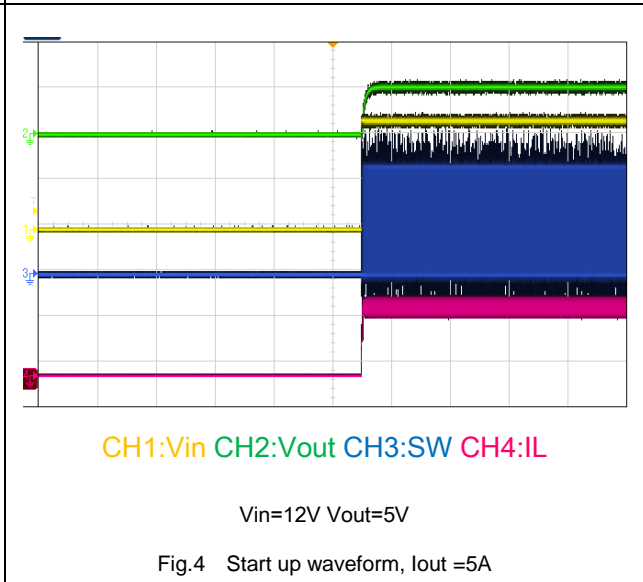
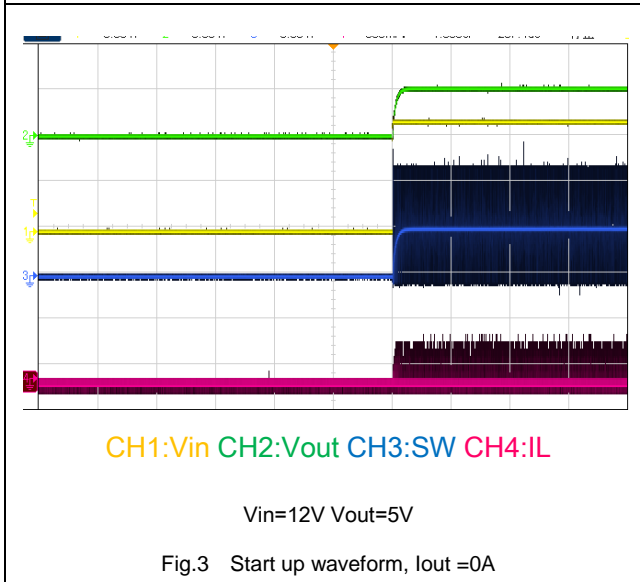
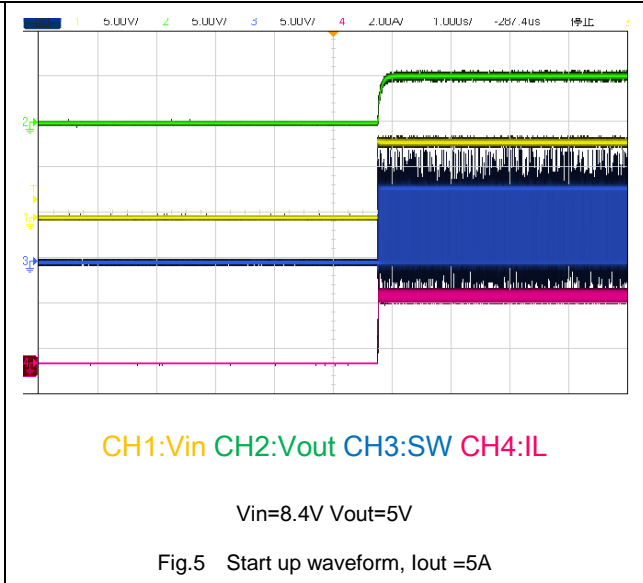
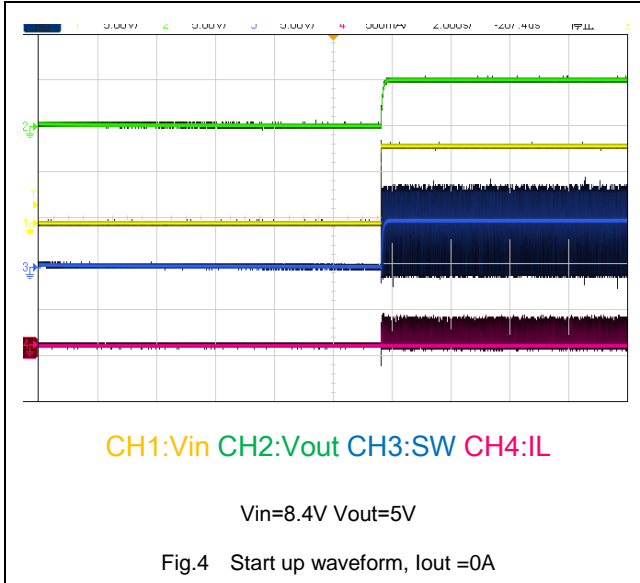

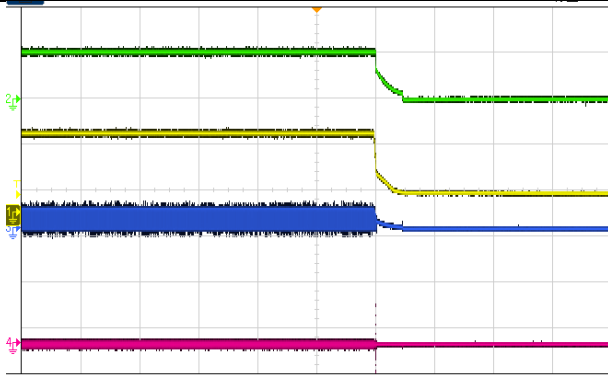

CH1:Vin CH2:Vout CH3:SW CH4:IL

Vin=8.4V Vout=5V

Fig.7 Shut down waveform, Iout =0A

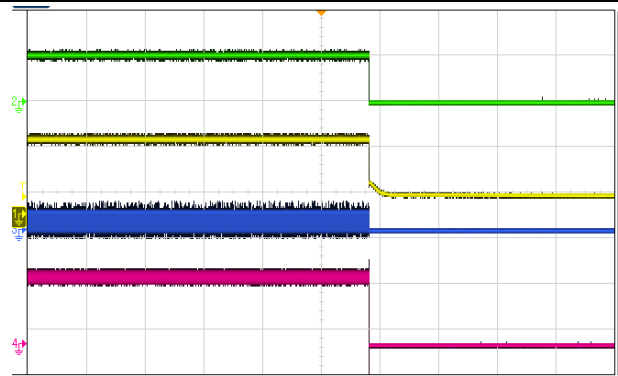

CH1:Vin CH2:Vout CH3:SW CH4:IL

Vin=8.4V Vout=5V

Fig.8 Shut down waveform, Iout =5A

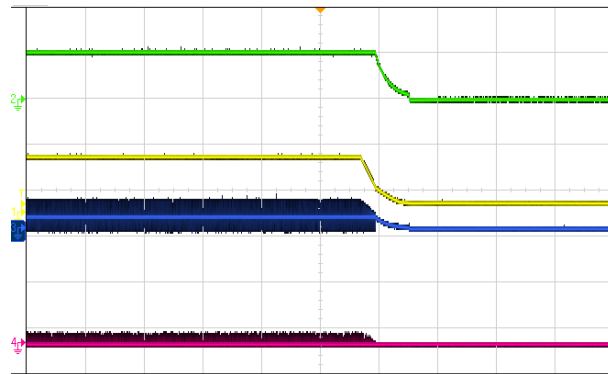

CH1:Vin CH2:Vout CH3:SW CH4:IL

Vin=12V Vout=5V

Fig.9 Shut down waveform, Iout =0A

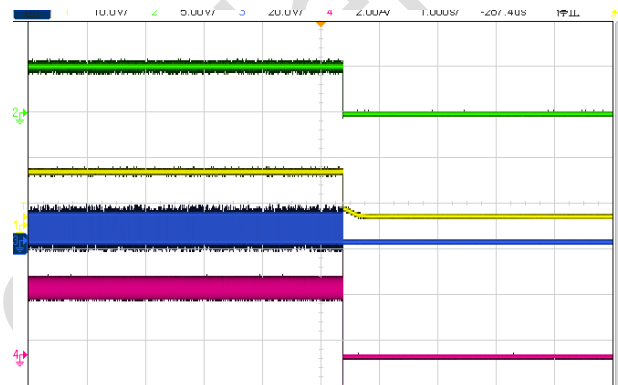

CH1:Vin CH2:Vout CH3:SW CH4:IL

Vin=12V Vout=5V

Fig.10 Shut down waveform, Iout =5A

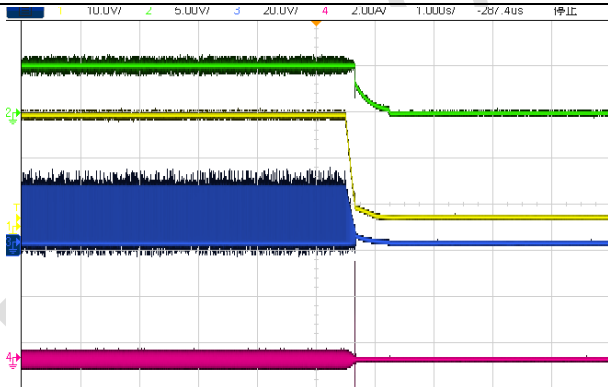

CH1:Vin CH2:Vout CH3:SW CH4:IL

Vin=24V Vout=5V

Fig.11 Shut down waveform, Iout =0A

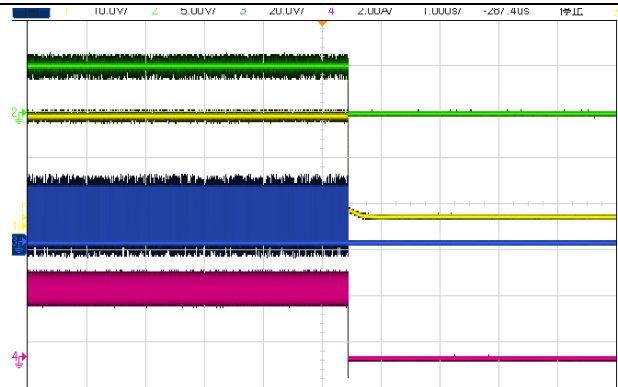

CH1:Vin CH2:Vout CH3:SW CH4:IL

Vin=24V Vout=5V

Fig.12 Shut down waveform, Iout =5A

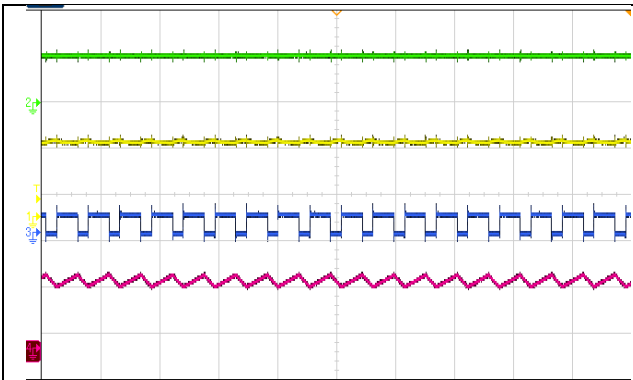

CH1:Vin CH2:Vout CH3:SW CH4:IL

Vin=8.4V Vout=5V

Fig.13 Steady State, Iout =5A

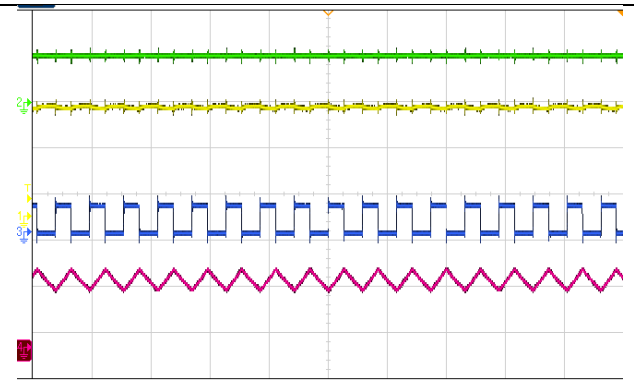

CH1:Vin CH2:Vout CH3:SW CH4:IL

Vin=12V Vout=5V

Fig.14 Steady State, Iout =5A

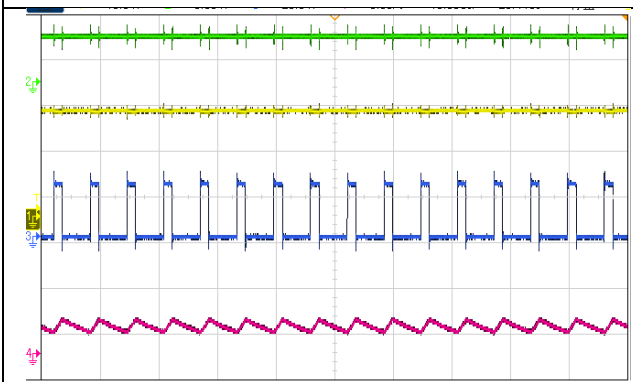

CH1:Vin CH2:Vout CH3:SW CH4:IL

Vin=24V Vout=5V

Fig.15 Steady State, Iout =5A

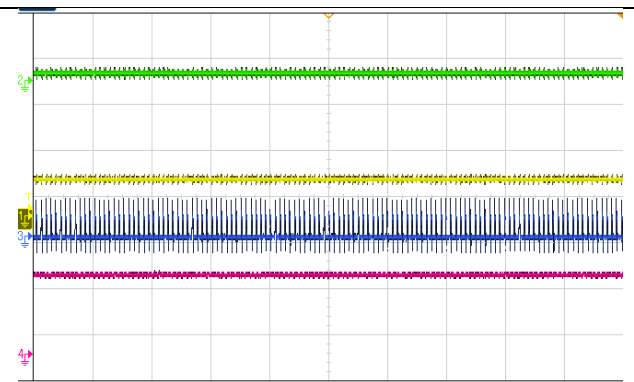

CH1:Vin CH2:Vout CH3:SW CH4:IL

Vin=8.4V Vout=5V

Fig.16 Short Circuit waveform

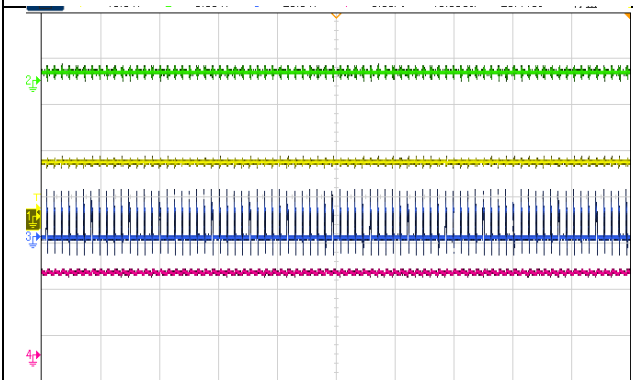

CH1:Vin CH2:Vout CH3:SW CH4:IL

Vin=12V Vout=5V

Fig.17 Short Circuit waveform

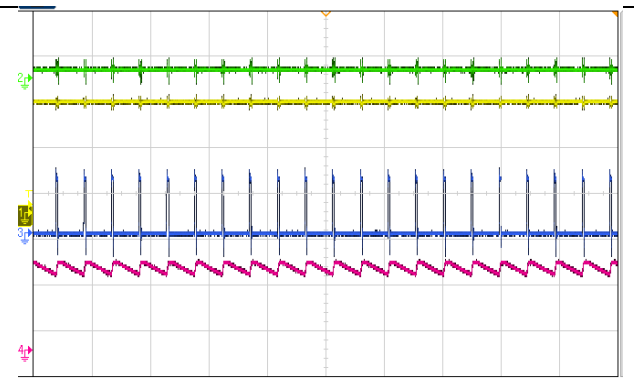

CH1:Vin CH2:Vout CH3:SW CH4:IL

Vin=24V Vout=5V

Fig.18 Short Circuit waveform

9 Detailed Descriptions

9.1 Overview

PL84051 integrates a high efficiency synchronous step-down switching regulator, which includes a 40V, 9mΩ high side and a 40V, 9mΩ low side MOSFETs to provide 5A continuous load current over 6.5V to 36V wide operating input voltage with 33V input over voltage protection.

PL84051 employs Constant ON time control. The switching frequency could be set to 150kHz, 300kHz, 600kHz or 1200kHz based on different resistor value between FREQ pin and GND pin. The device also features a programmable soft-start function and offers all kinds of protection features including cycle-by-cycle current limiting, input under voltage lockout (UVLO), output over voltage protection (OVP), input Over Voltage Protection, thermal shutdown and output short protection etc.

9.2 Functional Block Diagram

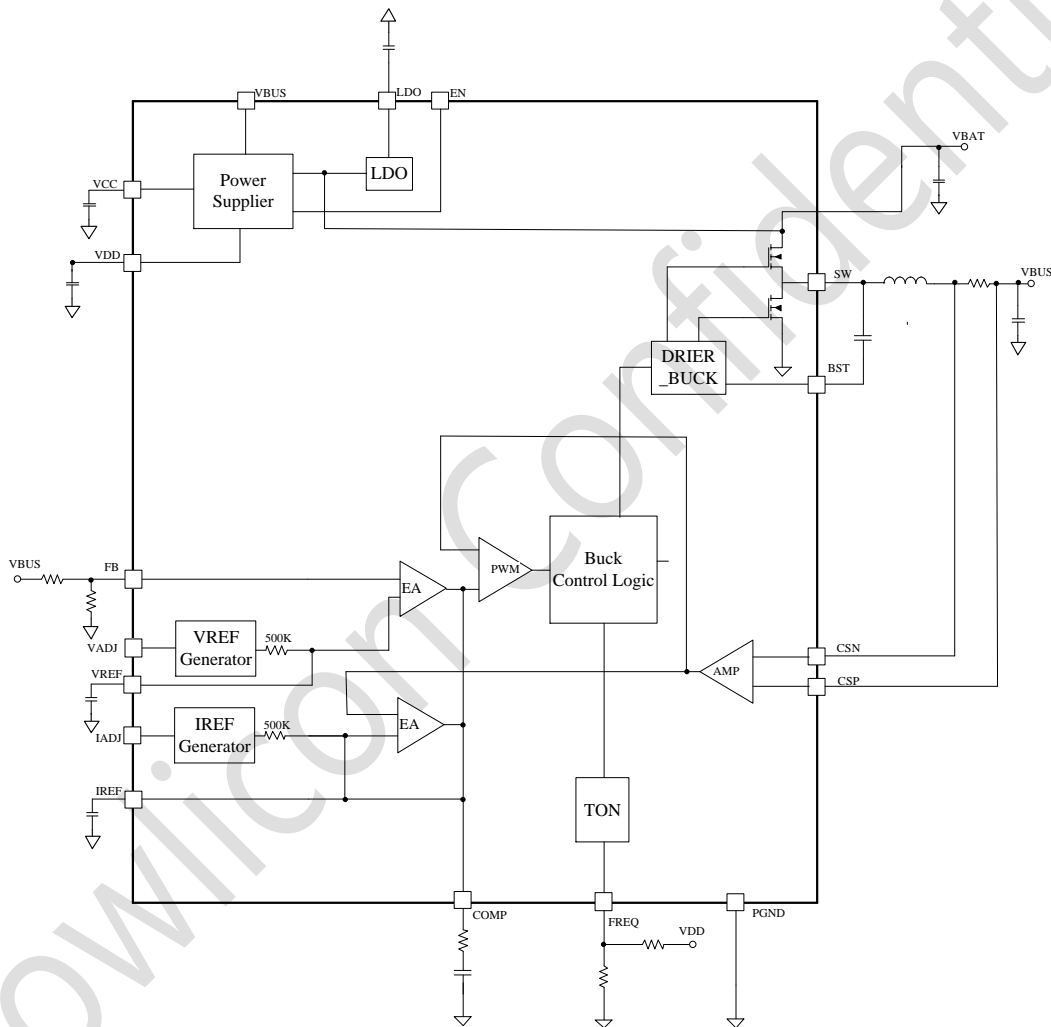

Fig. 19 PL84051 Block Diagram

9.3 Enable/UVLO

When EN is greater than 1.2V operating threshold, the control loop starts to work and regulate output to target voltage. When EN pin is below the standby threshold (1.1V typical), PL84051 stops working with only LDO is active to power MCU. EN is pulled high to 4V internally using a 2Meg resistor.

9.4 Over current Protection and short circuit protection

PL84051 provides cycle-by-cycle current limit to protect against over current and short circuit conditions. When VOUT is drop to UV threshold, PL84051 will go into hiccup mode to lower down power consumption.

9.5 Average Output Current Limiting

PL84051 provides optional average current limiting capability to limit either the output current. The average current limiting circuit uses an additional current sense resistor connected in series with the input supply or output voltage of the converter. If the drop across the sense resistor is greater than 40 mV, the gm amplifier regulates COMP voltage to lower down input or output current. The target constant current is given by Equation 1:

$$I_{CL(AVG)} = \frac{40 \text{ mV}}{R_{SNS}} \quad (1)$$

The average current loop can be disabled by shorting CSP to CSN.

9.6 Frequency Setting (FREQ) and frequency dithering

PL84051 switching frequency can be programmed at 150 kHz, 300 kHz or 600 kHz and 1200 kHz by voltage at FREQ pin to GND. When FREQ is connected to AGND, the switching frequency is set at 150 kHz. When FREQ is connected to VDD, the switching frequency is set at 300 kHz. A voltage divider between VDD and GND pin can be used to program switching frequency if 600 kHz or 1200 kHz is required.

9.7 Thermal Shutdown

PL84051 is protected by a thermal shutdown circuit that shuts down the device when the internal junction temperature exceeds 160°C (typical). The soft-start capacitor is discharged when thermal shutdown is triggered and the gate drivers are disabled. The converter automatically restarts when the junction temperature drops by the thermal shutdown hysteresis of 15°C below the thermal shutdown threshold.

9.8 VREF and IREF

VREF pin is the final reference voltage used in the voltage regulation loop. When VADJ is connected to VDD, VREF will be 2V in discharging mode and 1.8V in charging mode. When VADJ is connected to a PWM signal, PWM signal will first be chopped to 2V and filter out using an internal resistor and external capacitor on VREF pin. The capacitor on VREF pin is also acting as soft-start capacitor at power up or in output voltage transition period. It is recommend using a relatively large capacitor such as 470nF for VREF pin and IREF pin.

The same mechanism works for IADJ and IREF pin.

10 Applications and Implementation

The typical application on the first page is a basic PL84051 application circuit. External component selection is driven by the load requirement, and begins with the selection of RS1, RS2 and the inductor value. Next, the power MOSFETs need to be selected. Finally, C_{IN} and C_{OUT} are selected. This circuit can be configured for operation up to an input voltage of 32V.

10.1 R_{CS} Selection

As shown in Figures 1 and , Figures 20, output current sense resistor RCS should be placed between the bulk capacitor for VBUS and the decoupling capacitor. A low pass filter formed by RF and CF is recommended to reduce the switching noise and stabilize the current loop. If output current limit is not desired, then CSP/CSN pins should be shorted to either VBUS. Place, CSP/CSN symmetrically and keep them away switching signals such as BST SW, VIN, VBUS etc.

10.2 Inductor Selection

The operating frequency and inductor selection are interrelated in that higher operating frequencies allow the use of smaller inductor and capacitor values. The inductor value has a direct effect on ripple current. The inductor current ripple ΔI_L is typically set to 20% to 40% of the maximum inductor current in the boost region at $V_{IN(MIN)}$.

For a given ripple, the inductance terms in continuous mode are as follows:

$$L > \frac{V_{OUT} * (V_{IN(MAX)} - V_{OUT}) * 1000}{f * \Delta I_L * V_{IN(MAX)}} \text{ uH} \quad (3)$$

where: f is operating frequency, kHz

$V_{IN(MIN)}$ is minimum input voltage, V

$V_{IN(MAX)}$ is maximum input voltage, V

V_{OUT} is output voltage, V

ΔI_L is maximum inductor ripple current, A, usually select 20~40% maximum output current.

For high efficiency, choose an inductor with low core loss, such as ferrite. Also, the inductor should have low DC resistance to reduce the I²R losses, and must be able to handle the peak inductor current without saturating. To minimize radiated noise, use a toroid, pot core or shielded bobbin inductor.

10.3 C_{IN} and C_{OUT} Selection

Input capacitor C_{IN} is driven by the need to filter the input square wave current. Use a low ESR capacitor sized to handle the maximum RMS current, input RMS current is given by:

$$I_{CIN} = I_{OUT(MAX)} \times \sqrt{\frac{V_{OUT}}{V_{IN}} \times \left(1 - \frac{V_{OUT}}{V_{IN}}\right)} \quad (4)$$

This input current has a maximum at V_{IN} = 2V_{OUT}, I_{CIN(MAX)} = I_{OUT(MAX)}/2.

The effects of ESR (equivalent series resistance) and the bulk capacitance must be considered when choosing the right capacitor for a given output ripple voltage.

V_{OUT} ripple is given by:

$$\Delta V_{OUT} \leq \Delta I_L \times \left(ESR + \frac{1}{8 \times f \times C_{OUT}}\right) \quad (5)$$

Multiple capacitors placed in parallel may be needed to meet the ESR and RMS current handling requirements.

10.4 Output voltage setting

The PL84051 output voltage is set by an external feedback resistive divider carefully placed across the output capacitor. The 1% resistance accuracy of this resistor divider is preferred. The resultant feedback signal is compared with the internal precision 2V voltage reference by the error amplifier. The output voltage is given by the equation:

$$V_{OUT} = 2V \times \left(1 + \frac{R_1}{R_2}\right) \quad (6)$$

Where R₁ is the upper resistor and R₂ is the lower resistor in the feedback network.

11 PCB Layout

11.1 Guideline

Layout is a critical portion of good power supply design. The following guidelines will help users design a PCB with the best power conversion performance, thermal performance, and minimized generation of unwanted EMI.

1. The feedback network, resistor R1 and R2, should be kept close to the FB pin. Keep VBUS sensing path away from noisy nodes and preferably through a layer on the other side of shielding layer.
2. The input /output bypass capacitor must be placed as close as possible to the VIN/VBUS pin and ground. Grounding for both the input and output capacitors should consist of localized top side planes that connect to the GND pin and PAD. It is a good practice to place a ceramic cap near the VIN and VBUS pin to reduce the high frequency injection current.
3. The inductor L should be placed close to the SW pin to reduce magnetic and electrostatic noise.
4. Current sensing pairs (CSP1,CSN1), (CSP2,CSN2) need to be placed carefully, Layout the lines symmetrically and keep them away from noisy nodes such as BST, SW etc. Connect these nodes directly to the two terminals of current sensing resistors Rcs1, Rcs2 to form an accurate Kelvin connection.

11.2 Application Examples

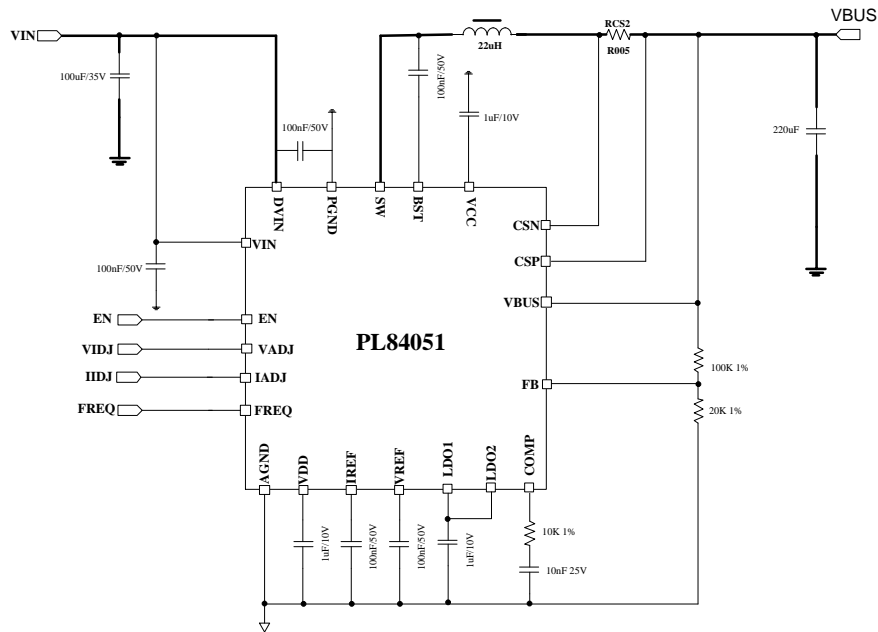

Fig. 20 Application Schematic (VABT:24V VBUS:12V IOOUT:5A)

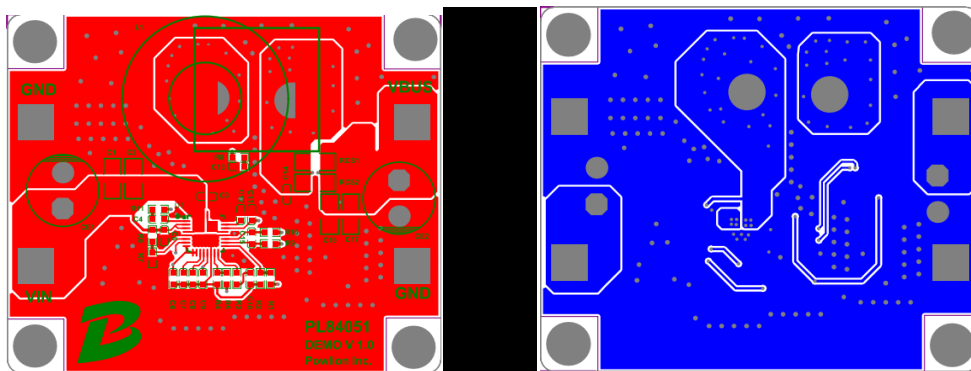

Fig 21 PCBLayout

