

DESCRIPTION:

With low holding and latching current, BT136 Series triacs are especially recommended for use on middle and small resistance type power load.

MAIN FEATURES:

symbol	value	unit
$I_{T(RMS)}$	4	A
V_{DRM}/V_{RRM}	600/800/1000	V
V_{TM}	≤ 1.7	V

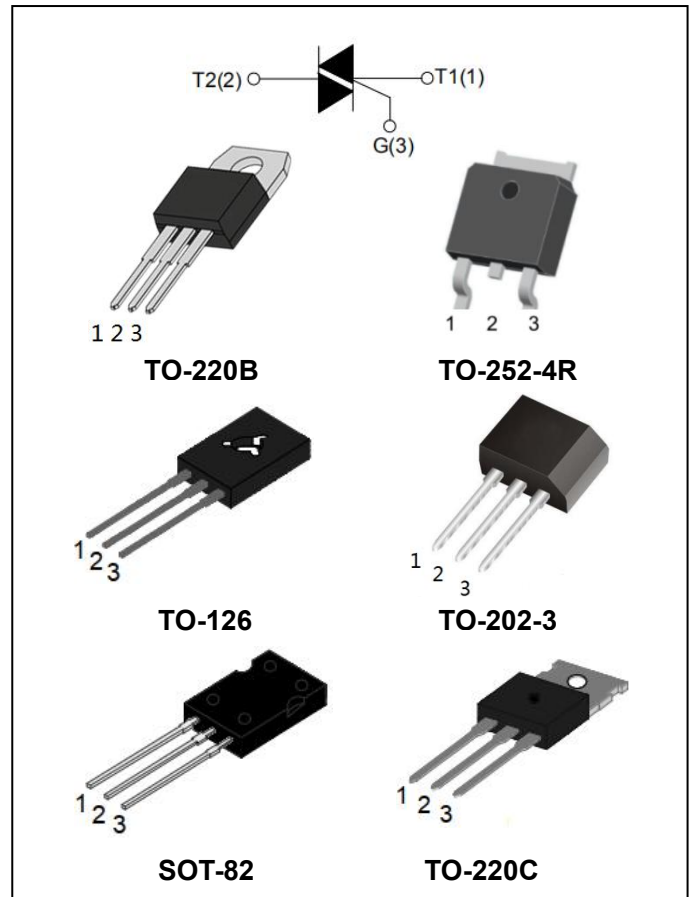

ABSOLUTE MAXIMUM RATINGS:

Parameter	Symbol	Value	Unit	
Storage junction temperature range	T_{stg}	-40~150	$^{\circ}C$	
Operating junction temperature range	T_j	-40~125	$^{\circ}C$	
Repetitive peak off-state voltage ($T_j=25^{\circ}C$)	V_{DRM}	600/800/1000	V	
Repetitive peak reverse voltage ($T_j=25^{\circ}C$)	V_{RRM}	600/800/1000	V	
RMS on-state current	$I_{T(RMS)}$	4	A	
Non repetitive surge peak on-state current (full cycle, F=50Hz)	I_{TSM}	25	A	
I^2t value for fusing ($t_p=10ms$)	I^2t	3.1	A^2s	
Critical rate of rise of on-state current ($I_G=2 \times I_{GT}$)	di/dt	I - II - III	50	A/ μs
		IV	10	

Peak gate current	I_{GM}	2	A
Average gate power dissipation	$P_{G(AV)}$	0.5	W
Peak gate power	P_{GM}	5	W

ELECTRICAL CHARACTERISTICS ($T_j=25^\circ\text{C}$ unless otherwise specified)

Parameter	Test Condition	Quadrant		Value			Unit
				T	D	E	
I_{GT}	$V_D=12\text{V}$, $R_L=33\Omega$	I - II - III	MAX	5	5	10	mA
		IV		5	10	25	
V_{GT}		I - II - III - IV		1.3			V
V_{GD}	$V_D=V_{DRM}$	I - II - III - IV	MIN	0.2			V
I_H	$I_T=100\text{mA}$		MAX	5	10	20	mA
I_L	$I_G=1.2I_{GT}$	I - III - IV	MAX	8	10	20	mA
		II		12	15	35	
dV/dt	$V_D=0.66 \times V_{DRM}$ $T_j=125^\circ\text{C}$ Gate open		MIN	10	20	50	V/ μs

STATIC CHARACTERISTICS

Symbol	Test Condition			Value	Unit
V_{TM}	$I_{TM}=5\text{A}$ $t_p=380\mu\text{s}$	$T_j=25^\circ\text{C}$	MAX	1.7	V
I_{DRM} I_{RRM}	$V_{DRM}=V_{RRM}$	$T_j=25^\circ\text{C}$	MAX	5	μA
		$T_j=125^\circ\text{C}$		0.5	mA

THERMAL RESISTANCES

Symbol	Test Condition		Value	Unit
$R_{th(j-c)}$	junction to case(AC)	TO-252-4R	2.8	$^\circ\text{C/W}$
		TO-220B(Non-Ins)/ TO-220C	2.6	

		TO-202-3	4.0	
		TO-126/SOT-82	3.7	

ORDERING INFORMATION

<p>BT</p> <p>Triacs</p>	<p>136</p> <p>$I_{T(RMS)}:4A$</p>	<p>-600</p> <p>V_{DRM}, V_{RRM}: 600: 600V 800: 800V 1000:1000V</p>	<p>D</p> <p>T: $I_{GT1-3} \leq 5mA, I_{GT4} \leq 5mA$ D: $I_{GT1-3} \leq 5mA, I_{GT4} \leq 10mA$ E: $I_{GT1-3} \leq 10mA, I_{GT4} \leq 25mA$</p>
--------------------------------	---	---	--

PACKAGE MECHANICAL DATA

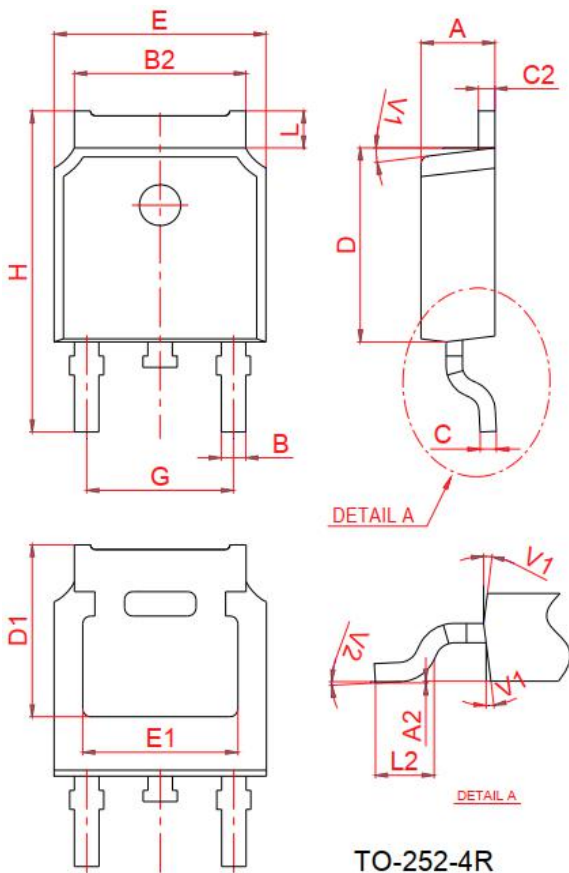

Ref.	Dimensions					
	Millimeters			Inches		
	Min.	Typ.	Max.	Min.	Typ.	Max.
A	2.2		2.4	0.087		0.094
A2	0		0.1	0		0.004
B	0.66		0.86	0.026		0.034
B2	5.1		5.46	0.201		0.215
C	0.46		0.58	0.018		0.023
C2	0.44		0.58	0.017		0.023
D	5.9		6.3	0.232		0.248
D1	5.30REF			0.211REF		
E	6.4		6.8	0.252		0.268
E1	4.63			0.182		
G	4.372		4.772	0.172		0.188
H	9.8		10.4	0.386		0.409
L	1.09		1.21	0.043		0.048
L2	1.35		1.65	0.053		0.065
V1		7°			7°	
V2	0°		6°	0°		6°

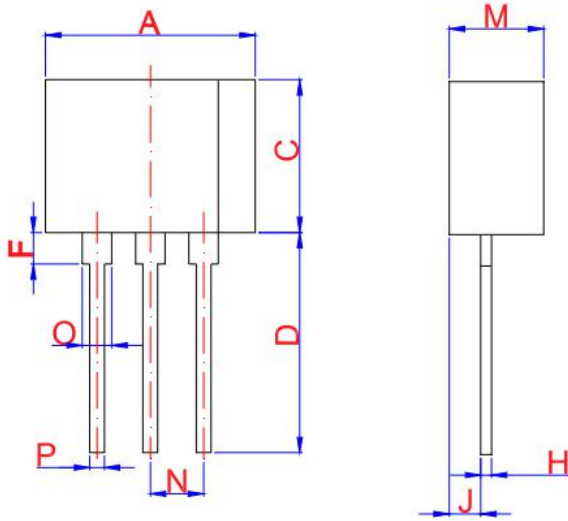

TO-202-3

Ref.	Dimensions					
	Millimeters			Inches		
	Min.	Typ.	Max.	Min.	Typ.	Max.
A	9.30		9.90	0.366		0.39
C	7.00		7.60	0.276		0.299
D	10.5		11.50	0.413		0.453
F	1.50		2.50	0.059		0.098
H	0.45		0.55	0.018		0.022
J	1.50		1.90	0.059		0.075
M	4.40		4.70	0.173		0.185
N	2	2.54			0.100	
O	1.20		1.50	0.047		0.059
P	0.60		0.80	0.024		0.031

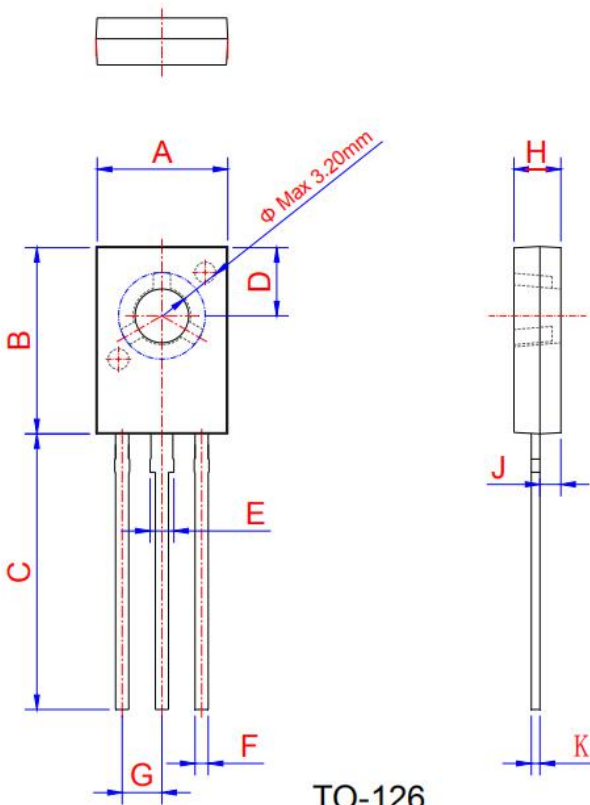

TO-126

Ref.	Dimensions					
	Millimeters			Inches		
	Min.	Typ.	Max.	Min.	Typ.	Max.
A	7.4		7.8	0.291		0.307
B	10.6		11.2	0.417		0.441
C	15.3		16.3	0.602		0.642
D	3.9		4.1	0.154		0.161
E	1.17		1.47	0.046		0.058
F	0.66		0.86	0.026		0.034
G		2.29			0.09	
H	2.5		2.9	0.098		0.114
K	0.45		0.6	0.018		0.024

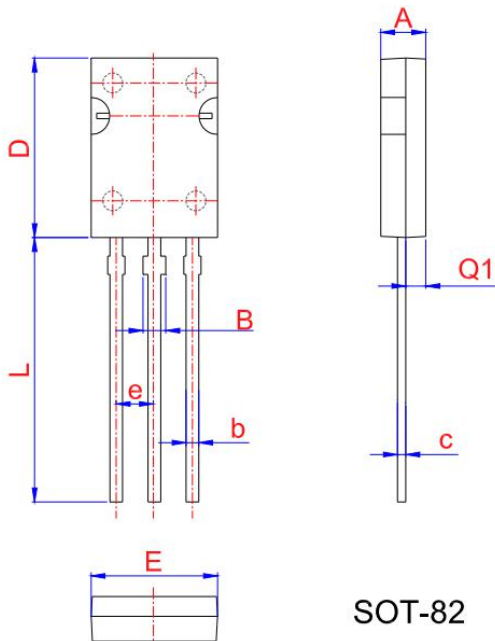

Ref.	Dimensions					
	Millimeters			Inches		
	Min.	Typ.	Max.	Min.	Typ.	Max.
A	2.45	2.55	2.65	0.096	0.100	0.104
b	0.71	0.76	0.81	0.028	0.030	0.032
B	1.27	1.37	1.45	0.050	0.054	0.057
c	0.48	0.50	0.52	0.019	0.020	0.021
D	10.60	10.80	11.00	0.417	0.425	0.433
E	7.30	7.5	7.70	0.287	0.295	0.303
e	2.24	2.29	2.34	0.088	0.090	0.092
L	15.30	15.60	15.90	0.602	0.614	0.626
Q1	1.17	1.27	1.37	0.046	0.050	0.054

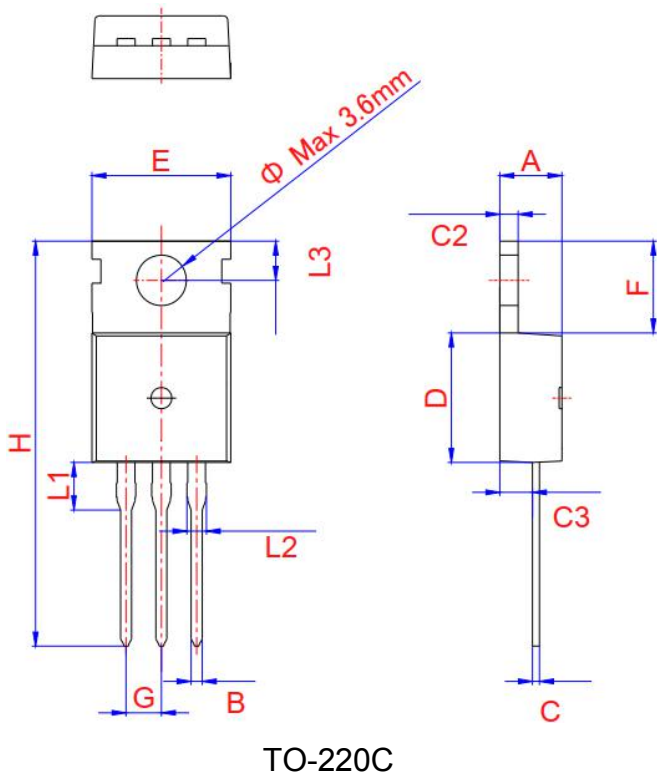

Ref.	Dimensions					
	Millimeters			Inches		
	Min.	Typ.	Max.	Min.	Typ.	Max.
A	4.3		4.5	0.169		0.177
B	0.7		0.9	0.028		0.035
C	0.45		0.6	0.018		0.024
C2	1.23	1.30	1.32	0.048	0.051	0.052
C3	2.2		2.6	0.087		0.102
D	8.9		9.9	0.35		0.39
E	9.9	10.1	10.3	0.39	0.398	0.406
F	6.3		6.9	0.248		0.272
G		2.54			0.1	
H	28		29.8	1.102		1.173
L1		3.39			0.133	
L2	1.14		1.7	0.045		0.067
L3	2.65		2.95	0.104		0.116
Φ		3.6			0.142	

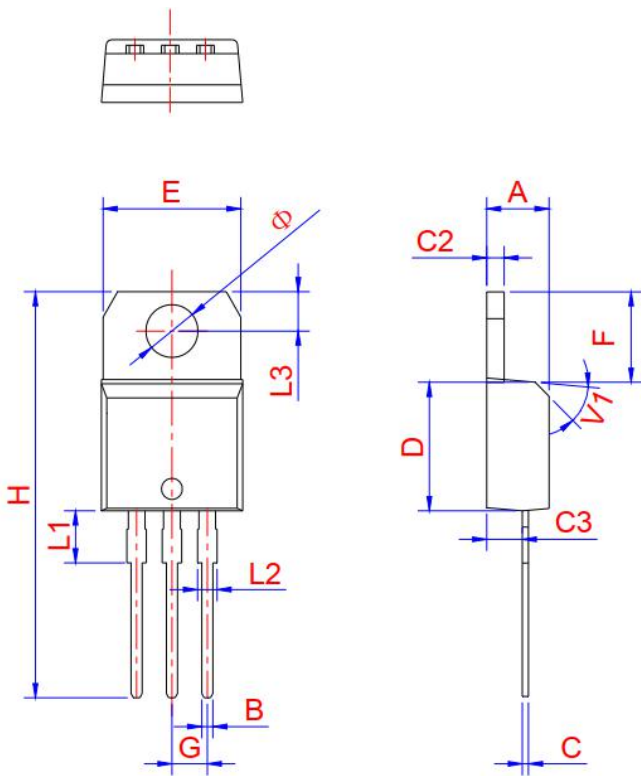

Ref.	Dimensions					
	Millimeters			Inches		
	Min.	Typ.	Max.	Min.	Typ.	Max.
A	4.4	4.47	4.6	0.173	0.176	0.181
B	0.61		0.88	0.024		0.035
C	0.46	0.50	0.7	0.018	0.02	0.028
C2	1.21	1.27	1.32	0.048	0.050	0.052
C3	2.4		2.72	0.094		0.107
D	8.6		9.7	0.339		0.382
E	9.8		10.4	0.386		0.409
F	6.55		6.95	0.258		0.274
G		2.54			0.1	
H	28		29.8	1.102		1.173
L1		3.75			0.148	
L2	1.14		1.7	0.045		0.067
L3	2.65		2.95	0.104		0.116
V1		45°			45°	
Φ	3.7	3.75	3.8	0.145	0.147	0.149

FIG.1: Maximum power dissipation versus RMS on-state current

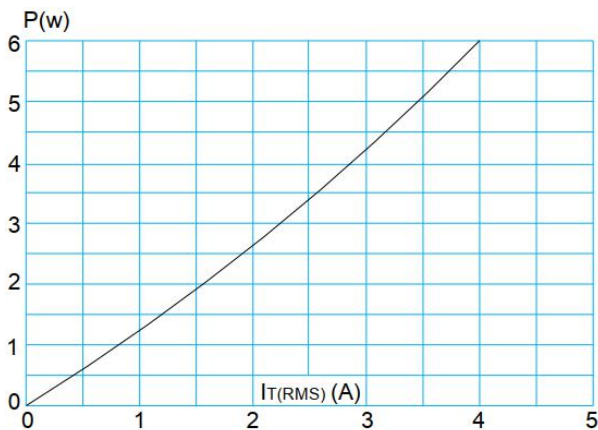

FIG.2: RMS on-state current versus case temperature

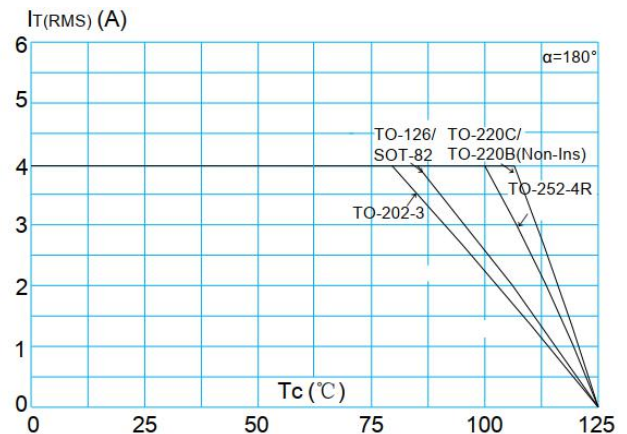

FIG.3: Surge peak on-state current versus number of cycles

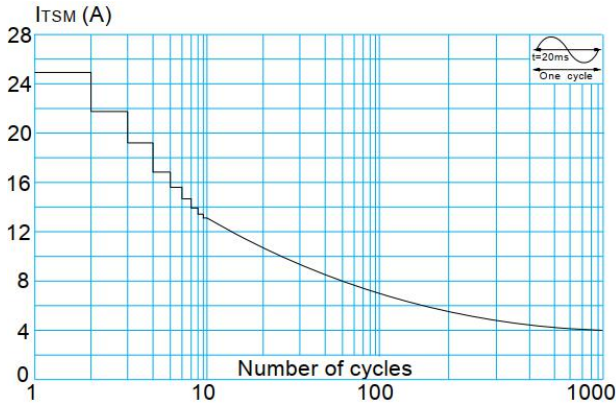

FIG.5: Non-repetitive surge peak on-state current for a sinusoidal pulse with width $t_p < 20ms$, and corresponding value of I^2t (I - II - III: $dI/dt < 50A/\mu s$; IV: $dI/dt < 10A/\mu s$)

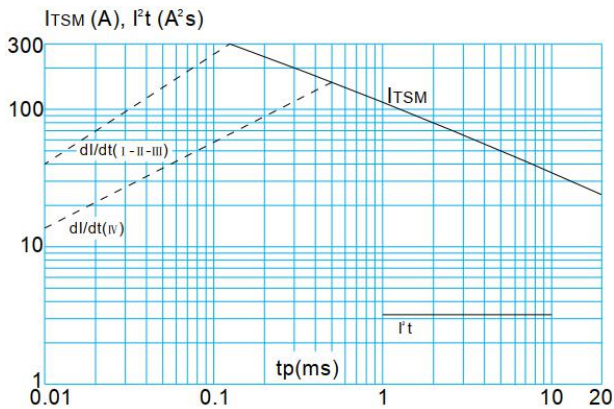

FIG.7: Relative variations of holding current versus junction temperature

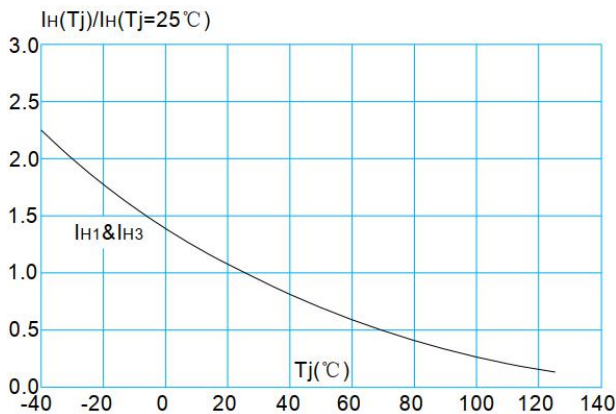

FIG.4: On-state characteristics (maximum values)

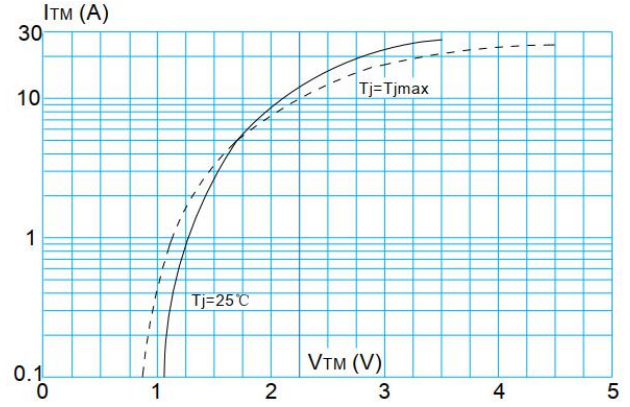

FIG.6: Relative variations of gate trigger current versus junction temperature

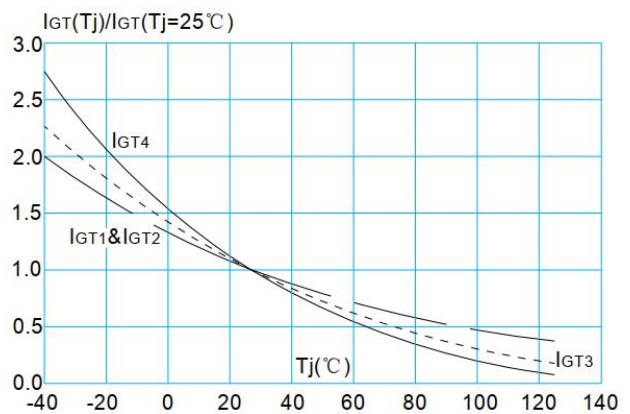

FIG.8: Relative variations of latching current versus junction temperature

