



SGM6031

Ultra-Low Power Step-Down Converters with Up to 200mA Output Current

GENERAL DESCRIPTION

The SGM6031 family provides a highly integrated ultra-low power step-down converter solution that is well suited for meeting the special needs of ultra-low power applications such as energy harvesting. The regulators are intended to step-down the voltage from an energy storage element such as a battery or super capacitor to supply the rail to low-voltage electronics. The regulated output has been optimized to provide high efficiency across low output currents (<10 μ A) to high currents (200mA).

The SGM6031 family integrates an optimized hysteretic controller for low-power applications. The internal circuitry uses a time-based sampling system to reduce the average quiescent current.

All the capabilities of SGM6031 are packed into a small UTDFN-1.5 \times 2-6L package. It operates over an ambient temperature range of -40 $^{\circ}$ C to +85 $^{\circ}$ C.

FEATURES

- **Industry's Highest Efficiency at Low Output Currents: Up to 90% with $I_{OUT} = 0.1\text{mA}$**
- **Ultra-Low Power Step-Down Converters**
- **200mA Maximum Output Current**
- **1.8V to 5.5V Input Operating Range**
- **Fixed Output Voltages: 1.0V, 1.2V, 1.5V, 1.8V, 2.5V, 2.8V, 3.0V and 3.3V**
- **Output Adjustable from 1.0V to 3.3V**
- **400nA Quiescent Current**
- **100% Duty Cycle (Pass Mode)**
- **Available in Green UTDFN-1.5 \times 2-6L Package**
- **-40 $^{\circ}$ C to +85 $^{\circ}$ C Ambient Temperature Range**

APPLICATIONS

Ultra-Low Power Applications
2-Cell and 3-Cell Alkaline-Powered Applications
Energy Harvesting
Solar Chargers
Thermal Electric Generator (TEG) Harvesting
Wireless Sensor Networks (WSN)
Low-Power Wireless Monitoring
Environmental Monitoring
Bridge and Structural Health Monitoring (SHM)
Smart Building Controls
Portable and Wearable Health Devices
Entertainment System Remote Controls

Ultra-Low Power Step-Down Converters with Up to 200mA Output Current

SGM6031

PACKAGE/ORDERING INFORMATION

MODEL	V _{OUT} (V)	STATUS ⁽¹⁾	PACKAGE DESCRIPTION	ORDERING NUMBER	PACKAGE MARKING	PACKING OPTION
SGM6031-1.0	1.0	ACTIVE	UTDFN-1.5×2-6L	SGM6031-1.0YUDT6G/TR	GJC XXX	Tape and Reel, 3000
SGM6031-1.2	1.2	ACTIVE	UTDFN-1.5×2-6L	SGM6031-1.2YUDT6G/TR	GJD XXX	Tape and Reel, 3000
SGM6031-1.5	1.5	ACTIVE	UTDFN-1.5×2-6L	SGM6031-1.5YUDT6G/TR	GJE XXX	Tape and Reel, 3000
SGM6031-1.8	1.8	ACTIVE	UTDFN-1.5×2-6L	SGM6031-1.8YUDT6G/TR	GJF XXX	Tape and Reel, 3000
SGM6031-2.5	2.5	ACTIVE	UTDFN-1.5×2-6L	SGM6031-2.5YUDT6G/TR	GK0 XXX	Tape and Reel, 3000
SGM6031-2.8	2.8	ACTIVE	UTDFN-1.5×2-6L	SGM6031-2.8YUDT6G/TR	GK1 XXX	Tape and Reel, 3000
SGM6031-3.0	3.0	ACTIVE	UTDFN-1.5×2-6L	SGM6031-3.0YUDT6G/TR	GX0 XXX	Tape and Reel, 3000
SGM6031-3.3	3.3	ACTIVE	UTDFN-1.5×2-6L	SGM6031-3.3YUDT6G/TR	GK2 XXX	Tape and Reel, 3000
SGM6031-ADJ	ADJ	ACTIVE	UTDFN-1.5×2-6L	SGM6031-ADJYUDT6G/TR	GLF XXX	Tape and Reel, 3000

NOTES:

1. The marketing status values are defined as follows:

ACTIVE: Product device recommended for new designs.

PREVIEW: Device has been announced but is not in production. Samples may or may not be available.

2. XXX = Date Code.

MARKING INFORMATION

GYG — Chip I.D.

X XX

— Date code - Week (01, 02, 03 ...)

— Date code - Year ("A" = 2010, "B" = 2011 ...)

Green (RoHS & HSF): SG Micro Corp defines "Green" to mean Pb-Free (RoHS compatible) and free of halogen substances. If you have additional comments or questions, please contact your SGMICRO representative directly.

ABSOLUTE MAXIMUM RATINGS

Input Voltage Range on VIN, EN, VOUT, FB, SW
.....-0.3V to 6V
Peak Currents VIN, VOUT 510mA
Junction Temperature +150°C
Storage Temperature Range..... -65°C to +150°C
Lead Temperature (Soldering, 10s) +260°C
ESD Susceptibility
HBM..... 7000V
MM..... 400V
CDM 1000V

RECOMMENDED OPERATING CONDITIONS

Input Voltage Range..... 1.8V to 5.5V
Input Capacitance, C_{IN} 22µF (MIN)
Output Capacitance, C_{OUT} 10µF (MIN), 22µF (TYP)
Inductance, L..... 10µH (MIN)
Operating Junction Temperature Range.....-40°C to +125°C
Operating Ambient Temperature Range-40°C to +85°C

OVERSTRESS CAUTION

Stresses beyond those listed may cause permanent damage to the device. Functional operation of the device at these or any other conditions beyond those indicated in the operational section of the specification is not implied. Exposure to absolute maximum rating conditions for extended periods may affect reliability.

ESD SENSITIVITY CAUTION

This integrated circuit can be damaged by ESD if you don't pay attention to ESD protection. SGMICRO recommends that all integrated circuits be handled with appropriate precautions. Failure to observe proper handling and installation procedures can cause damage. ESD damage can range from subtle performance degradation to complete device failure. Precision integrated circuits may be more susceptible to damage because very small parametric changes could cause the device not to meet its published specifications.

DISCLAIMER

SG Micro Corp reserves the right to make any change in circuit design, specification or other related things if necessary without notice at any time.

Ultra-Low Power Step-Down Converters with Up to 200mA Output Current

SGM6031

PIN CONFIGURATION

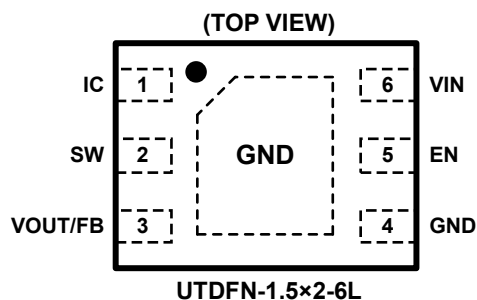

PIN DESCRIPTION

PIN	NAME	FUNCTION
1	IC	For Internal Connection.
2	SW	Switching Node. Connect to output inductor.
3	VOUT	Step-Down Regulator Output.
	FB	Feedback Input (adjustable voltage version only). The voltage at this pin is regulated to 1.0V. Connected to the resistor divider between output and ground to set output voltage.
4	GND	Ground. Power and IC ground. All signals are referenced to this pin.
5	EN	Enable Input. Input logic high to enable this circuit and logic low to shut down. Do not leave this pin unconnected.
6	VIN	Input Voltage. Connect to input power source.
Exposed Pad	GND	Connect to GND.

Ultra-Low Power Step-Down Converters with Up to 200mA Output Current

SGM6031

ELECTRICAL CHARACTERISTICS

($V_{IN} = 3.6V$, $V_{OUT} = 1.2V$, typical values are at $T_A = +25^\circ C$. Full = $-40^\circ C$ to $+85^\circ C$, unless otherwise noted.)

PARAMETER	SYMBOL	CONDITIONS	TEMP	MIN	TYP	MAX	UNITS
QUIESCENT CURRENT							
Buck Enabled State	I_Q	$V_{IN} = 1.8V$, no load, no switching	$+25^\circ C$		400	700	nA
OUTPUT							
Feedback Voltage	V_{FB}		$+25^\circ C$	0.98	1.0	1.02	V
Output Accuracy			$+25^\circ C$	-2		2	%
			Full	-3		3	
Output Line Regulation		$V_{IN} = 1.8V$ to $5.5V$, $I_{OUT} = 100\mu A$	$+25^\circ C$		0.3		%/V
Output Load Regulation		$I_{OUT} = 100\mu A$ to $200mA$	$+25^\circ C$		0.002		%/mA
Output Ripple		$I_{OUT} = 1mA$	$+25^\circ C$		15		mV _{PP}
POWER SWITCH							
High-Side Switch ON Resistance	$R_{DS(ON)}$		$+25^\circ C$		510	620	m Ω
Low-Side Switch ON Resistance			$+25^\circ C$		530	690	
Cycle-by-Cycle Current Limit	I_{LIM}		$+25^\circ C$	355	430	510	mA
Maximum Switching Frequency	f_{SW}		$+25^\circ C$		1.4		MHz
INPUT							
Input Under Voltage Protection	V_{IN_UVLO}	V_{IN} falling	$+25^\circ C$	1.19	1.3		V
EN							
Voltage for EN High Setting	V_{IH}		Full	1.1			V
Voltage for EN Low Setting	V_{IL}		Full			0.4	
THERMAL SHUTDOWN							
Thermal Shutdown	T_{TSD}				160		$^\circ C$
Thermal Shutdown Hysteresis	T_{HYS}				20		$^\circ C$

TYPICAL PERFORMANCE CHARACTERISTICS

T_A = +25°C, unless otherwise noted.

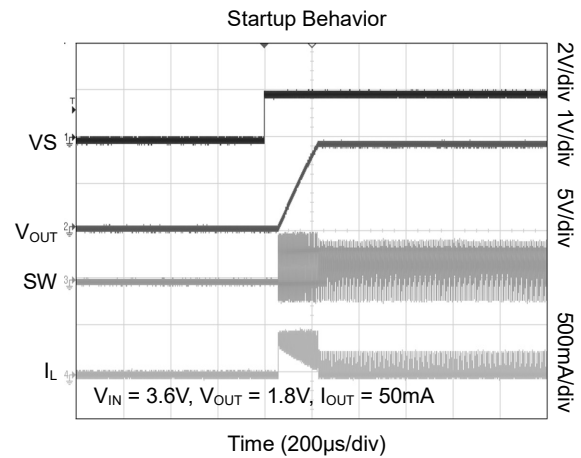
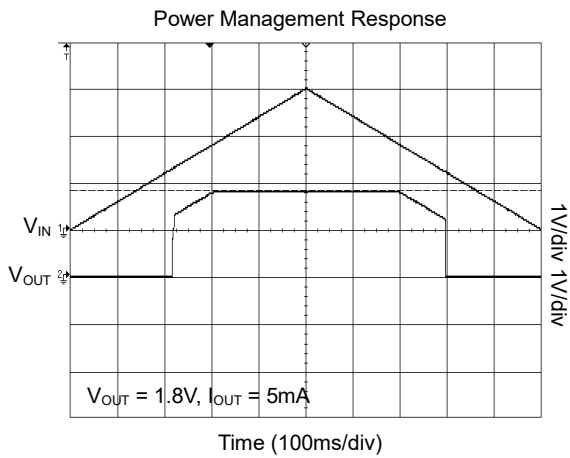
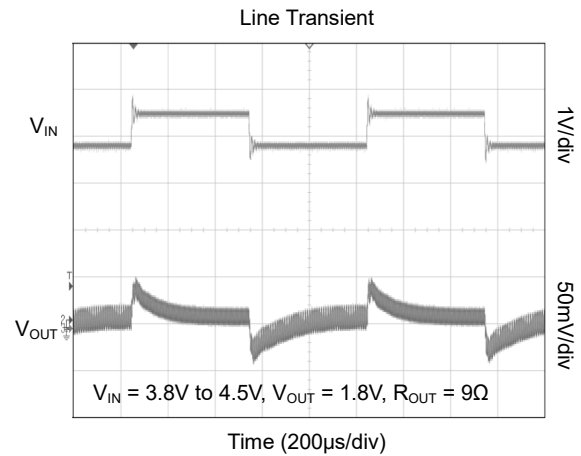
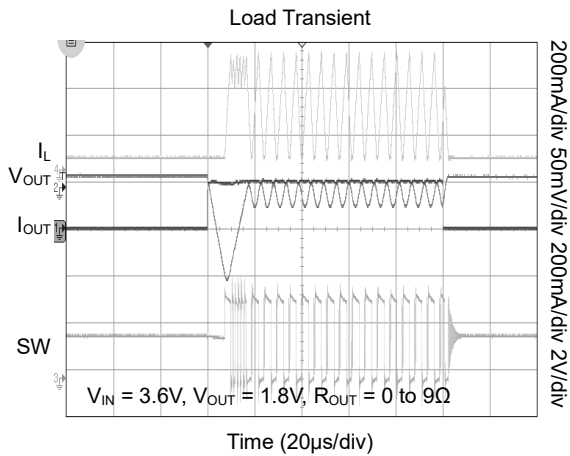
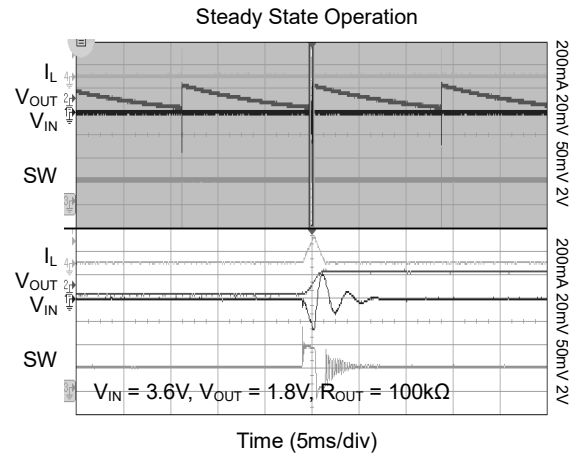
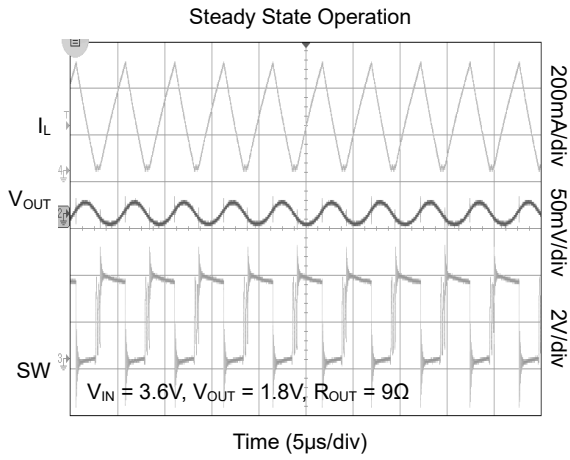

TYPICAL PERFORMANCE CHARACTERISTICS (continued)

T_A = +25°C, unless otherwise noted.

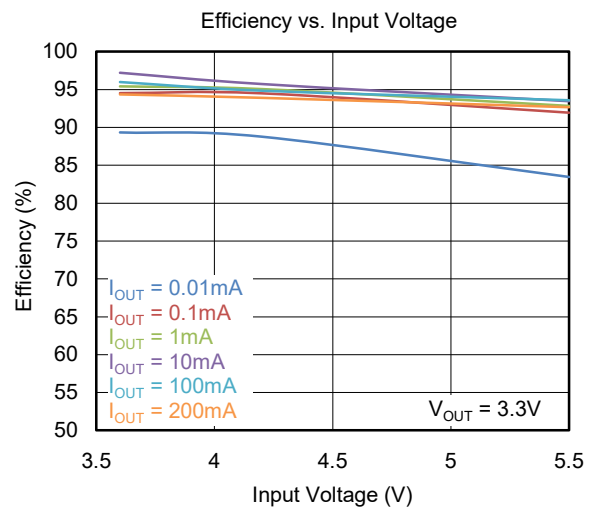
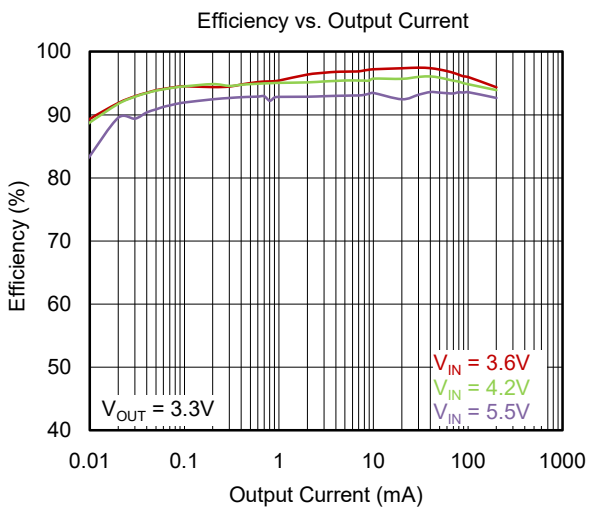
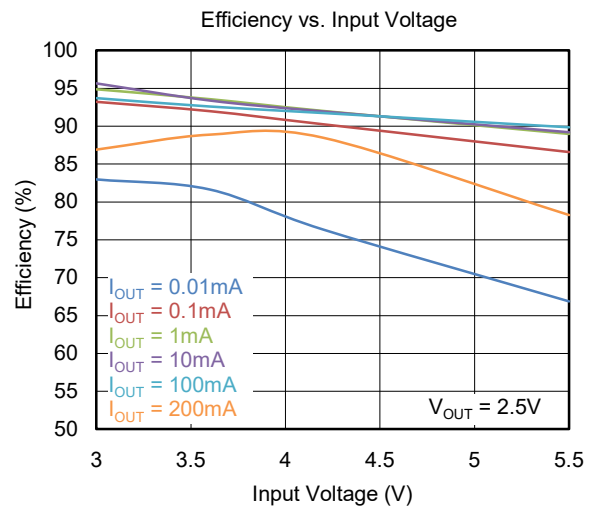
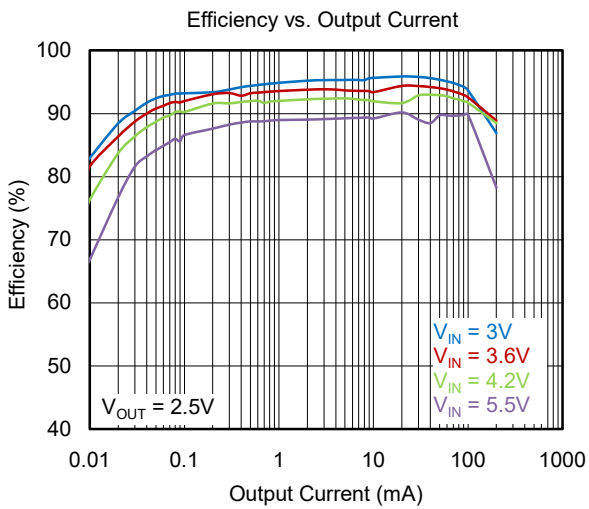
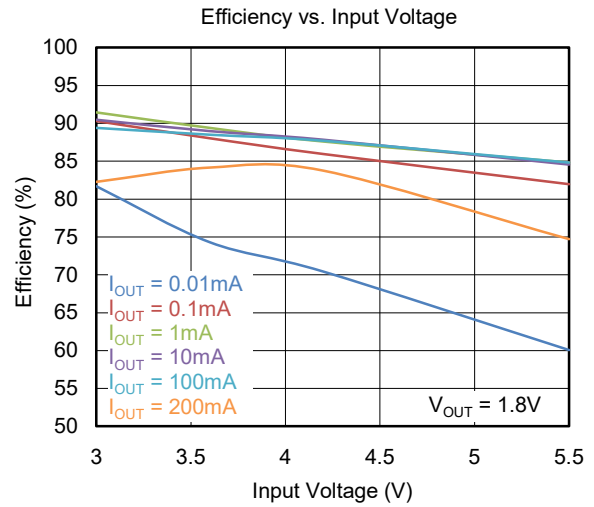
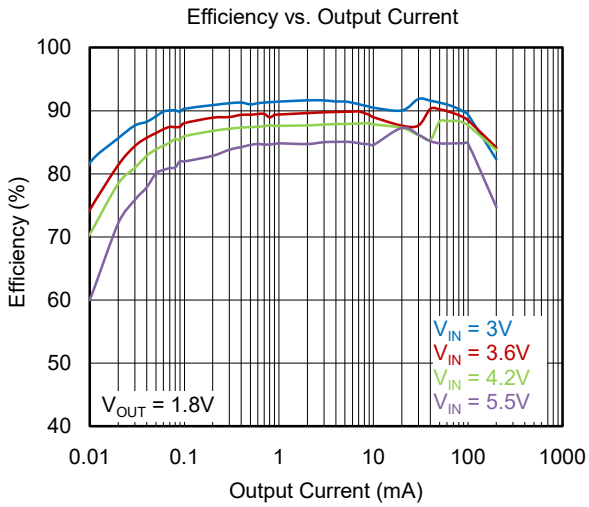

TYPICAL PERFORMANCE CHARACTERISTICS (continued)

T_A = +25°C, unless otherwise noted.

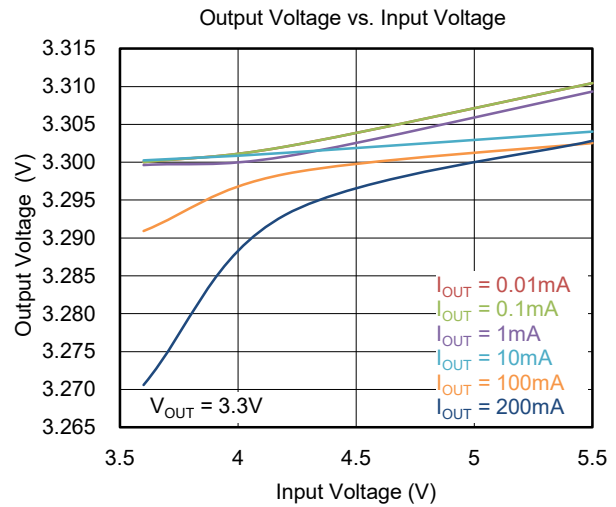
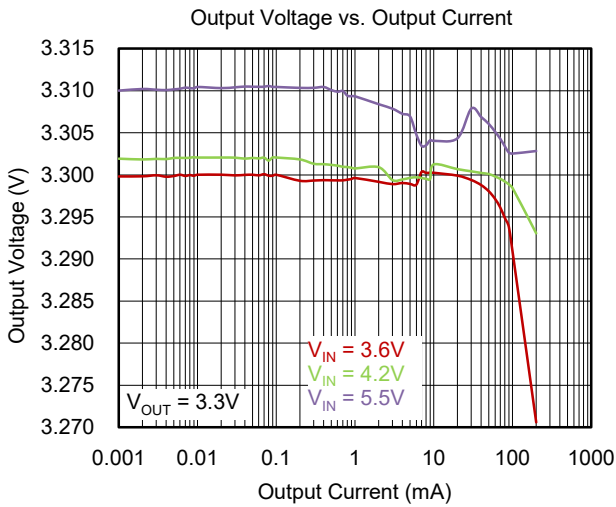
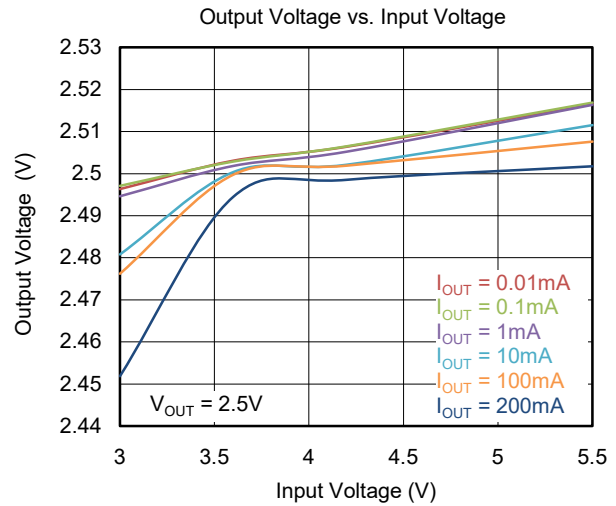
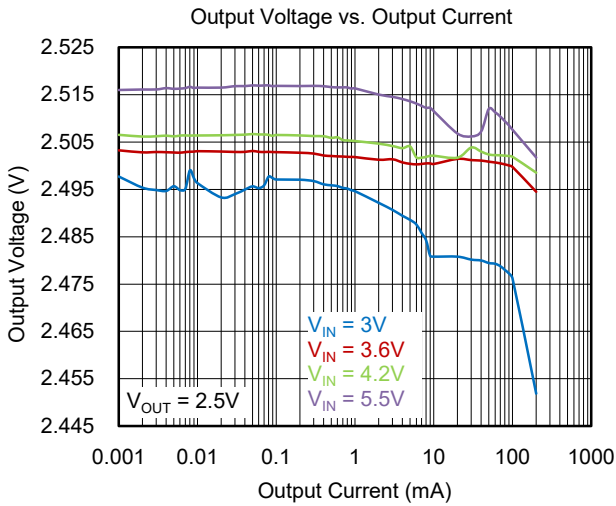
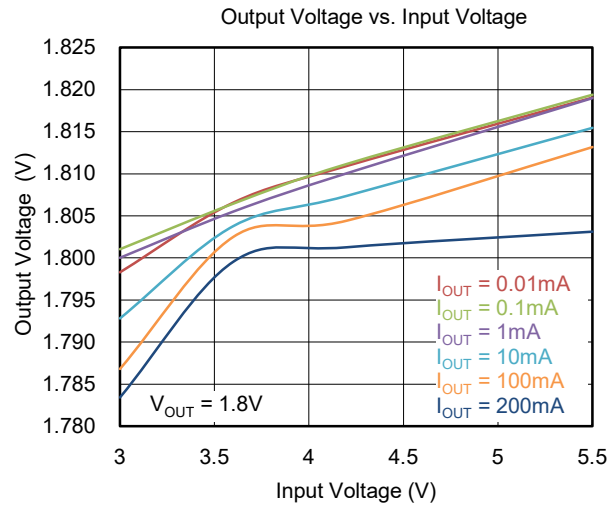
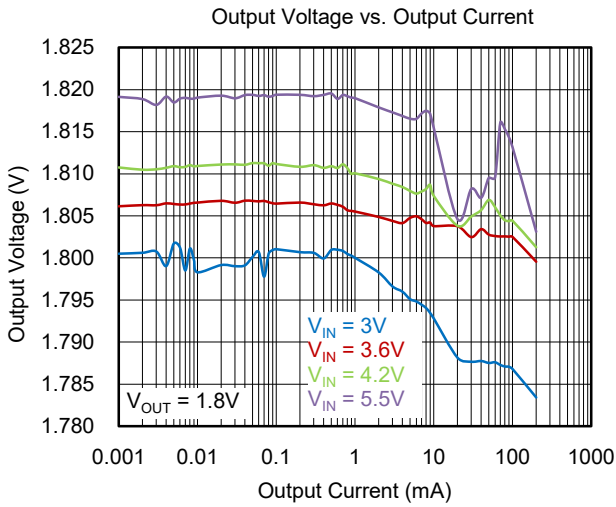

TYPICAL PERFORMANCE CHARACTERISTICS (continued)

T_A = +25°C, unless otherwise noted.

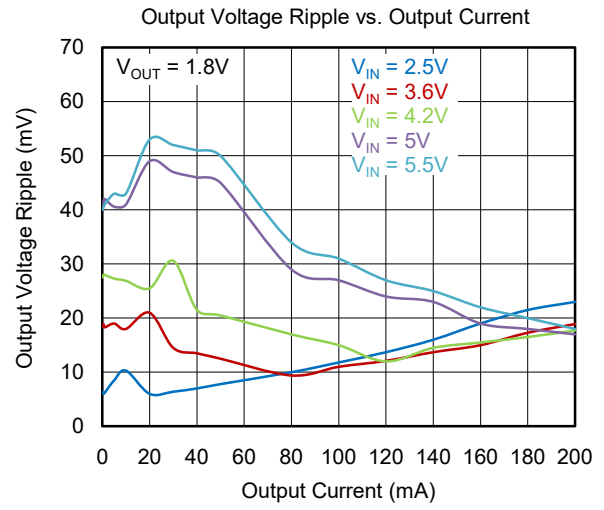
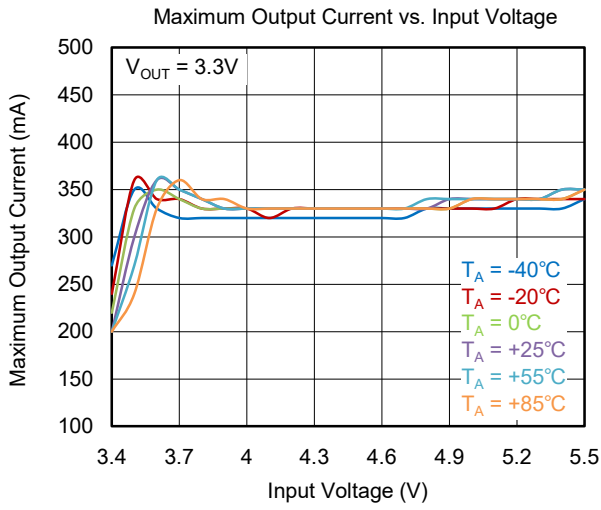

TYPICAL APPLICATION CIRCUITS

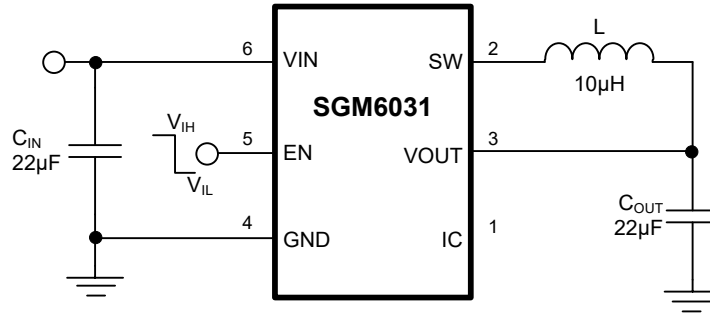

Figure 1. Fixed Voltage Typical Application Circuit

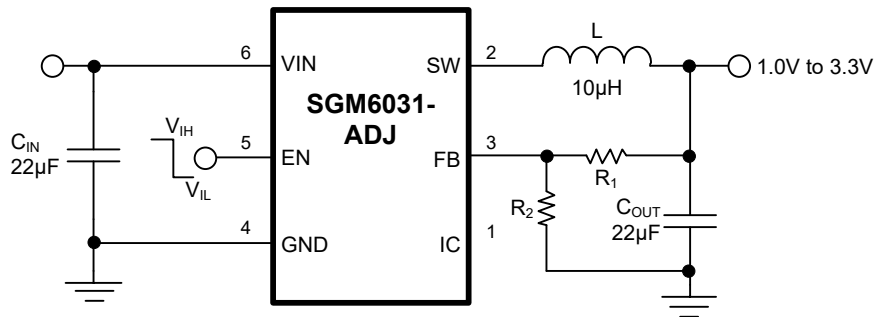

Figure 2. Adjustable Voltage Typical Application Circuit

FUNCTIONAL BLOCK DIAGRAM

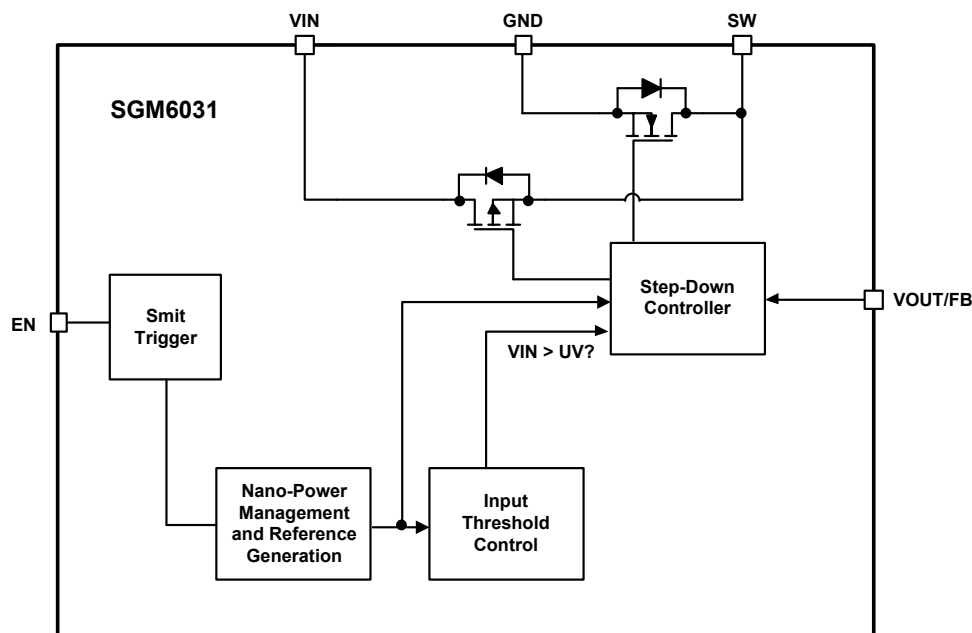

Figure 3. Block Diagram

DETAILED DESCRIPTION

The SGM6031 family provides a highly integrated ultra-low power step-down converter solution that is well suited for meeting the special needs of ultra-low power applications such as energy harvesting. The regulators are intended to step-down the voltage from an energy storage element such as a battery or super capacitor in order to supply the rail to low-voltage electronics. The regulated output has been optimized to provide high efficiency across low output currents (less than 10 μ A) to high currents (200mA).

The SGM6031 family integrates an optimized hysteretic controller for low-power applications. The internal circuitry uses a time-based sampling system to reduce the average quiescent current.

Step-Down Converter Operation

The step-down regulator in the SGM6031 family takes input power from VIN, steps it down and provides a regulated voltage at the VOUT pin. It employs pulse frequency modulation (PFM) control to regulate the

voltage close to the desired reference voltage. The current through the inductor is controlled through internal current sense circuitry. The peak current in the inductor is controlled to maintain high efficiency of the converter across a wide input current range. The SGM6031 converter delivers an average output current of 200mA with a peak inductor current of 430mA. The step-down regulator is disabled when the voltage on VIN reaches the UVLO condition. The UVLO level is continuously monitored. The step-down regulator continues to operate in pass (100% duty cycle) mode, passing the input voltage to the output, as long as VIN is greater than UVLO and less than VIN minus IOUT times RDS(ON) of the high-side FET (that is, VIN - IOUT \times RDS(ON)-HS). In order to save power from being dissipated through other ICs on this supply rail, the step-down regulator can be enabled and disabled through the EN pin for systems that desire to turn off the regulated output.

DETAILED DESCRIPTION (continued)

Under-Voltage Lockout (UVLO)

When the input voltage is below the UVLO threshold, the device is shut down. If the input voltage rises above the UVLO threshold plus hysteresis, the IC will restart.

Thermal Shutdown (TSD)

A thermal shutdown function is implemented to prevent damage caused by excessive heat and power dissipation. Once a temperature of typically +160°C is exceeded, the device is shut down. The device is released from shutdown automatically when the junction temperature decreases by +20°C.

Nano-Power Management and Efficiency

The high efficiency of the SGM6031 family is achieved through the nano-power management circuitry and algorithm. This feature essentially samples and holds

all references in order to reduce the average quiescent current. That is, the internal circuitry is only active for a short period of time and then off for the remaining period of time at the lowest feasible duty cycle.

The efficiency versus output current and efficiency versus input voltage are plotted for three different output voltages for SGM6031 device in Typical Characteristics. All data points were captured by averaging the overall input current. This must be done, due to the periodic biasing scheme implemented through the nano-power management circuitry. The input current efficiency data was gathered using a source meter set to average over at least 25 samples and at the highest accuracy sampling rate. Each data point takes a long period of time to gather in order to properly measure the resulting input current when calculating the efficiency.

Table 1. Recommended Inductors

INDUCTANCE (μ H)	DIMENSIONS (mm)	PART NUMBER	MANUFACTURER
10	2.0 × 2.5 × 1.2	DFE252012C-H-100M	Toko
10	4.0 × 4.0 × 1.7	LPS4018-103M	Coilcraft

APPLICATION INFORMATION

The SGM6031 family is step-down converters. Their low quiescent currents make them ideal for battery powered systems that are operated at low duty cycles in order to achieve low total power levels.

Setting the Output Voltage

The output voltage is set using a resistive voltage divider from the output voltage to FB pin. The voltage divider divides the output voltage down to the feedback voltage by the ratio:

$$V_{FB} = V_{OUT} \frac{R_2}{R_1 + R_2}$$

Where V_{FB} is the feedback voltage and V_{OUT} is the output voltage. Thus the output voltage is:

$$V_{OUT} = 1.0 \times \frac{R_1 + R_2}{R_2}$$

The value for R_2 can be as high as 1MΩ.

For example, for a 2V output voltage, R_2 is 1MΩ, and R_1 is 1MΩ.

Detailed Design Procedure

The recommended 10μH inductor and 22μF input capacitor are used. Since no large load transients are expected, the minimum 22μF output capacitor is used. Had a large load transient been expected, we would have sized the capacitor using $I_{TRAN} = C_{OUT} \times \Delta V_{OUT} / \Delta TIME$ where ΔV_{OUT} is amount of V_{OUT} droop allowed for the time of the transient.

Inductor Selection

The internal-control circuitry is designed to control the switching behavior with a nominal inductance of 10μH ±20%. The saturation current of the inductor' should be at least 25% higher than the maximum cycle-by-cycle current limit per the electrical specs table (I_{LIM}) in order to account for load transients. Because this device is a hysteretic controller, it is a naturally stable system (single order transfer function). However, the smaller the inductor value is, the faster the switching currents are.

A list of inductors recommended for this device is shown in Table 1.

Output Capacitor Selection

The output capacitor is chosen based on transient response behavior and ripple magnitude. The lower the capacitor value, the larger the ripple will become and the larger the droop will be in the case of a transient response. It is recommended to use at least a 22μF output capacitor for most applications.

Input Capacitor Selection

The bulk input capacitance is recommended to be a minimum of 22μF ±20%. This bulk capacitance is used to suppress the lower frequency transients produced by the switching converter. There is no upper bound to the input-bulk capacitance. In addition, a high-frequency bypass capacitor of 0.1μF is recommended in parallel with the bulk capacitor. The high-frequency bypass is used to suppress the high-frequency transients produced by the switching converter.

REVISION HISTORY

NOTE: Page numbers for previous revisions may differ from page numbers in the current version.

OCTOBER 2017 – REV.A.1 to REV.A.2

Changed the marking information for SGM6031-3.0YUDT6G..... 2

AUGUST 2017 – REV.A to REV.A.1

Changed SGM6031-3.0 STATUS from PREVIEW to ACTIVE 2

Changes from Original (JUNE 2017) to REV.A

Changed from product preview to production data..... All

PACKAGE OUTLINE DIMENSIONS

UTDFN-1.5×2-6L

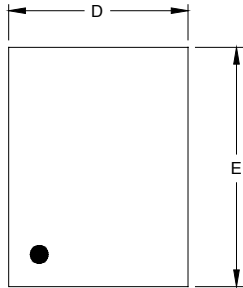

TOP VIEW

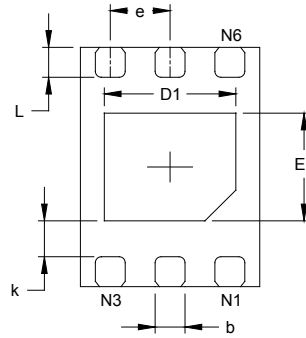

BOTTOM VIEW

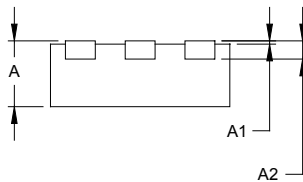

SIDE VIEW

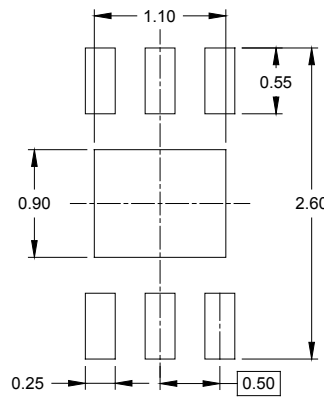

RECOMMENDED LAND PATTERN (Unit: mm)

Symbol	Dimensions In Millimeters		Dimensions In Inches	
	MIN	MAX	MIN	MAX
A	0.500	0.600	0.020	0.024
A1	0.000	0.050	0.000	0.002
A2	0.152 REF		0.006 REF	
D	1.400	1.600	0.055	0.063
D1	1.000	1.200	0.039	0.047
E	1.900	2.100	0.075	0.083
E1	0.800	1.000	0.031	0.039
k	0.300 REF		0.012 REF	
b	0.200	0.300	0.008	0.012
e	0.500 BSC		0.020 BSC	
L	0.200	0.300	0.008	0.012

PACKAGE INFORMATION

TAPE AND REEL INFORMATION

REEL DIMENSIONS



TAPE DIMENSIONS



NOTE: The picture is only for reference. Please make the object as the standard.

KEY PARAMETER LIST OF TAPE AND REEL

Package Type	Reel Diameter	Reel Width W1 (mm)	A0 (mm)	B0 (mm)	K0 (mm)	P0 (mm)	P1 (mm)	P2 (mm)	W (mm)	Pin1 Quadrant
UTDFN-1.5×2-6L	7"	9.5	1.70	2.30	0.75	4.0	4.0	2.0	8.0	Q2

000001

PACKAGE INFORMATION

CARTON BOX DIMENSIONS



NOTE: The picture is only for reference. Please make the object as the standard.

KEY PARAMETER LIST OF CARTON BOX

Reel Type	Length (mm)	Width (mm)	Height (mm)	Pizza/Carton
7" (Option)	368	227	224	8
7"	442	410	224	18

DD0002