



# AAP6013A

## 7.5V to 36V Input Supply, CC/CV Synchronous Buck PWM Converter with Adjustable Switching Frequency

### GENERAL DESCRIPTION

The AAP6013A is a voltage mode synchronous buck converter that achieves excellent load and line regulation responses. The device operates from a wide input voltage range of 7.5V to 36V. The AAP6013A provides protection functions including input under-voltage lockout, output under-voltage protection and dual-output CC/CV control.

The AAP6013A is in a Green TQFN-4×4-24BL package. It is rated over the -40°C to +85°C temperature range.

### APPLICATIONS

Car Chargers/Adaptors  
Rechargeable Portable Devices  
Battery Chargers

### FEATURES

- Wide 7.5V to 36V Input Voltage Range
- 20mΩ/10mΩ Internal N-Channel MOSFETs
- High Efficiency up to 97%
- 0.8V Reference Voltage
- Fast Load Transient Response
- Dual Outputs with Independent Programmable Constant-Current Control
- Minimum On-Time Linearly Dependent on Switching Period
- Nearly Zero Input Current at Output Over-Current Protection or Output Under-Voltage Protection
- Internal Soft-Start
- Monotonic Startup into Pre-biased Outputs
- Programmable Output Cable Compensation
- Adjustable Switching Frequency up to 800kHz
- Thermal Shutdown Protection
- Available in a Green TQFN-4×4-24BL Package
- RoHS Compliant and Halogen Free

### SIMPLIFIED SCHEMATIC

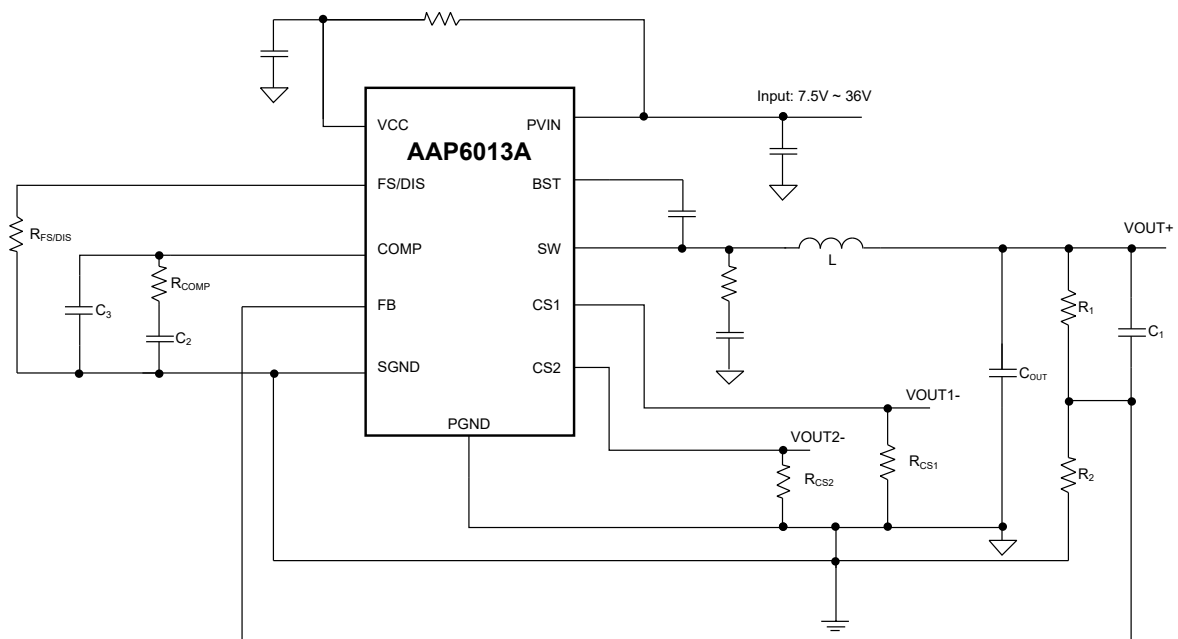

Figure 1. Simplified Schematic

# 7.5V to 36V Input Supply, CC/CV Synchronous Buck PWM AAP6013A Converter with Adjustable Switching Frequency

## PACKAGE/ORDERING INFORMATION

MODEL	PACKAGE DESCRIPTION	SPECIFIED TEMPERATURE RANGE	ORDERING NUMBER	PACKAGE MARKING	PACKING OPTION
AAP6013A	TQFN-4x4-24BL	-40°C to +85°C	AAP6013A/TR	AAP6013A YTQF24 XXXXX	Tape and Reel, 3000

## MARKING INFORMATION

NOTE: XXXXX = Date Code and Vendor Code.

**XXXXX**

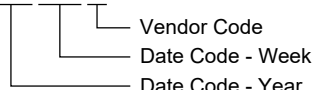

Green (RoHS & HSF): SG Micro Corp defines "Green" to mean Pb-Free (RoHS compatible) and free of halogen substances. If you have additional comments or questions, please contact your SGMICRO representative directly.

## ABSOLUTE MAXIMUM RATINGS

VCC, PVIN Voltages .....	-0.3V to 42V
SW Voltage (DC) .....	-0.3V to V <sub>CC</sub> + 0.3V
BST Voltage.....	V <sub>SW</sub> - 0.3V to V <sub>SW</sub> + 6V
FB, FS/DIS, COMP, CS1, CS2 Voltages .....	-0.3V to 6V
Package Thermal Resistance	
TQFN-4x4-24BL, $\theta_{JA}$ .....	45°C/W
Junction Temperature .....	+150°C
Storage Temperature Range .....	-65°C to +150°C
Lead Temperature (Soldering, 10s) .....	+260°C
ESD Susceptibility	
HBM.....	2000V
CDM .....	1000V

## RECOMMENDED OPERATING CONDITIONS

Operating Temperature Range .....	-40°C to +85°C
-----------------------------------	----------------

## OVERSTRESS CAUTION

Stresses beyond those listed in Absolute Maximum Ratings may cause permanent damage to the device. Exposure to absolute maximum rating conditions for extended periods may affect reliability. Functional operation of the device at any conditions beyond those indicated in the Recommended Operating Conditions section is not implied.

## ESD SENSITIVITY CAUTION

This integrated circuit can be damaged if ESD protections are not considered carefully. SGMICRO recommends that all integrated circuits be handled with appropriate precautions. Failure to observe proper handling and installation procedures can cause damage. ESD damage can range from subtle performance degradation to complete device failure. Precision integrated circuits may be more susceptible to damage because even small parametric changes could cause the device not to meet the published specifications.

## DISCLAIMER

SG Micro Corp reserves the right to make any change in circuit design, or specifications without prior notice.

# 7.5V to 36V Input Supply, CC/CV Synchronous Buck PWM Converter with Adjustable Switching Frequency

## AAP6013A

### PIN CONFIGURATION

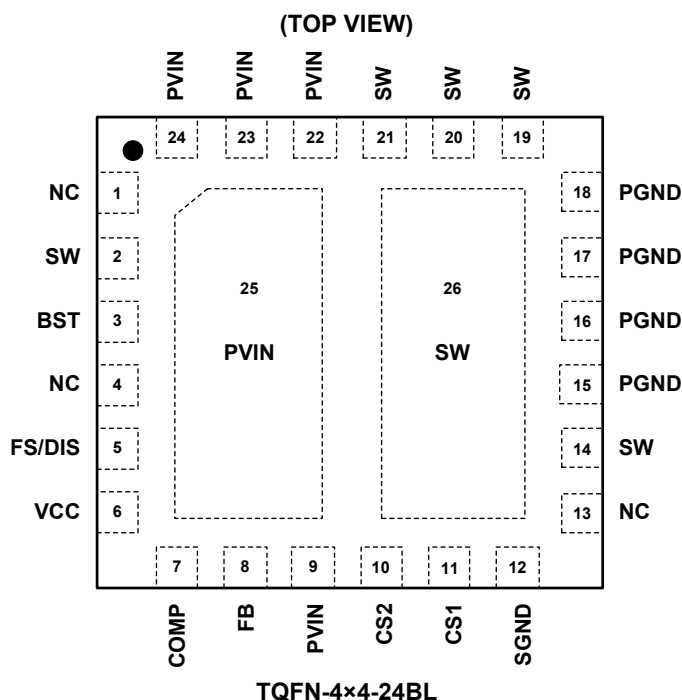

### PIN DESCRIPTION

PIN	NAME	DESCRIPTION
1, 4, 13	NC	No Connection. Leave it floating.
2, 14, 19, 20, 21, 26	SW	Switching Node. Connect an inductor between SW pin and the regulator output.
3	BST	Bootstrap Pin. Connect a 100nF capacitor between BST pin and SW pin. This capacitor provides power supply to the integrated high-side MOSFET gate driver.
5	FS/DIS	Switching Frequency Set Pin or Disable Pin. Connect a resistor between this pin and SGND to set the switching frequency or pull this pin below 0.375V (TYP) to shut down the device.
6	VCC	Input Supply Voltage Pin.
7	COMP	Output Pin of Error Amplifier. Connect an appropriate compensation network between this pin and the ground.
8	FB	Output Voltage Feedback Input.
9, 22, 23, 24, 25	PVIN	Power Input Pin. Connecting a 0.1μF capacitor from PVIN to PGND pins near the IC to improve EMI.
10	CS2	Output 2 Current-Sense (+) Pin.
11	CS1	Output 1 Current-Sense (+) Pin.
12	SGND	Ground Pin. Connect this pin to the PCB signal ground.
15,16, 17, 18	PGND	Power Ground for Low-side MOSFET Gate Driver.

# 7.5V to 36V Input Supply, CC/CV Synchronous Buck PWM AAP6013A Converter with Adjustable Switching Frequency

## ELECTRICAL CHARACTERISTICS

( $V_{CC} = 12V$  and  $T_A = +25^\circ C$ , unless otherwise noted.)

PARAMETER	SYMBOL	CONDITIONS	MIN	TYP	MAX	UNITS
<b>Supply Input</b>						
Supply Voltage Range	$V_{CC}$		7.5		36	V
Supply Input Current	$I_{CC}$	$V_{FB} = 1V$		1.2	1.6	mA
Shutdown Current	$I_{SD}$	$V_{FS/DIS} < 0.375V$ (TYP)		1.2		mA
<b>Power-On Reset</b>						
Rising $V_{CC}$ Threshold			6.64	7	7.4	V
Falling $V_{CC}$ Threshold				6		V
<b>Oscillator and Soft-Start</b>						
Switching Frequency	$f_{SW}$	$R_{FS/DIS} = 60k\Omega$		100		kHz
		$R_{FS/DIS} = 30k\Omega$	170	200	230	
		$R_{FS/DIS} = 10k\Omega$		530		
Saw-Tooth Amplitude	$\Delta V_{OSC}$			1.6		V
Soft-Start Time	$t_{SS}$			3		ms
Maximum Duty Cycle	$D_{MAX}$	$V_{FB} = 0.85V$		88		%
Minimum On-Time	$t_{MIN}$	$f_{SW} = 125kHz$		600		ns
<b>Reference Voltage</b>						
Reference Voltage	$V_{REF}$	Measured at FB Pin	0.772	0.8	0.828	V
<b>Power MOSFET</b>						
High-side MOSFET On-Resistance	$R_{DS(ON)_H}$			20	25	m $\Omega$
Low-side MOSFET On-Resistance	$R_{DS(ON)_L}$			10	14	m $\Omega$
<b>Over-Current Protection and FB Under-Voltage Protection</b>						
CS1 Threshold	$V_{CS1}$		76	84	92	mV
CS2 Threshold	$V_{CS2}$		76	84	92	mV
Low-side MOSFET Current Limit	$I_{LIM}$			18		A
Over-Voltage Threshold as percentage of $V_{OUT}$	$V_{OVP}$	Percentage of $V_{REF}$		110		%
FB Pin Under-Voltage Threshold	$V_{FB-UV}$		410	465	520	mV
Recycle Time	$t_R$	FB UV, $f_{SW} = 100kHz$		5.5		s
		FB UV, $f_{SW} = 500kHz$		1.1		
<b>Thermal Shutdown</b>						
Thermal Shutdown Threshold	$T_{SD}$	$T_A$ rising		150		$^\circ C$
Thermal Shutdown Hysteresis	$T_{SD\_HYS}$	$T_A$ falling below $T_{SD}$		15		$^\circ C$

# AAP6013A 7.5V to 36V Input Supply, CC/CV Synchronous Buck PWM Converter with Adjustable Switching Frequency

## TYPICAL PERFORMANCE CHARACTERISTICS

At  $T_A = +25^\circ\text{C}$ ,  $V_{IN} = 12\text{V}$  and  $V_{OUT} = 5\text{V}$ , unless otherwise noted.

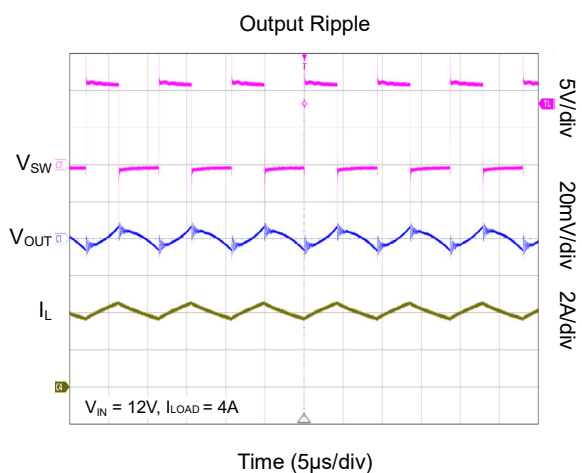
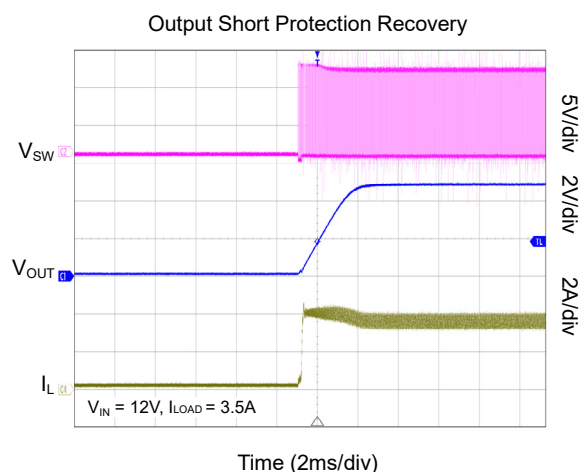
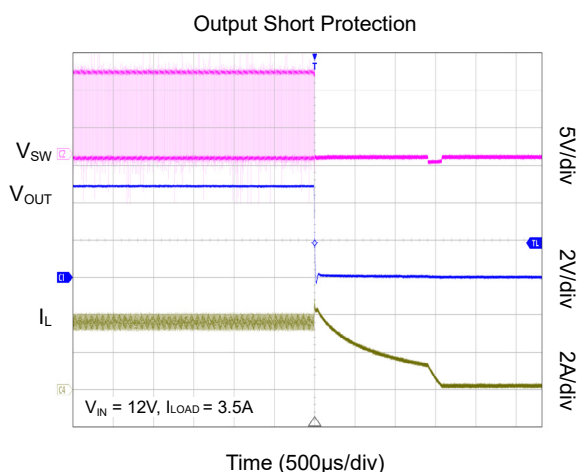
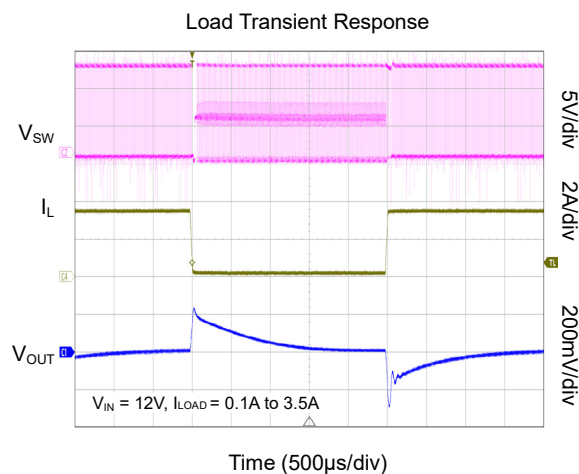
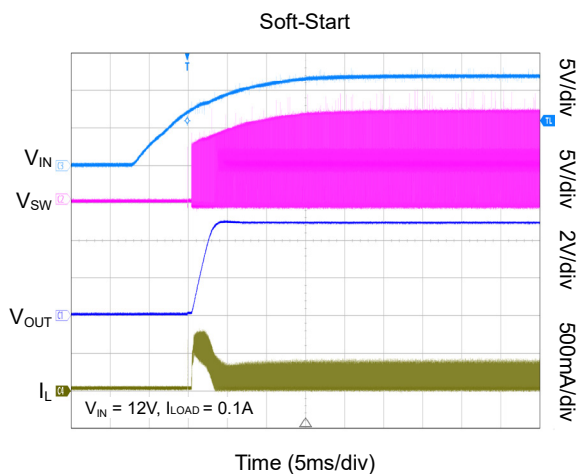

# AAP6013A 7.5V to 36V Input Supply, CC/CV Synchronous Buck PWM Converter with Adjustable Switching Frequency

## TYPICAL PERFORMANCE CHARACTERISTICS (continued)

At  $T_A = +25^\circ\text{C}$ ,  $V_{IN} = 12\text{V}$  and  $V_{OUT} = 5\text{V}$ , unless otherwise noted.

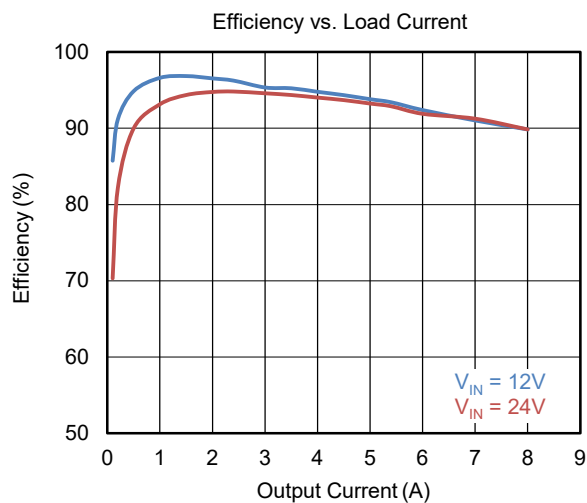
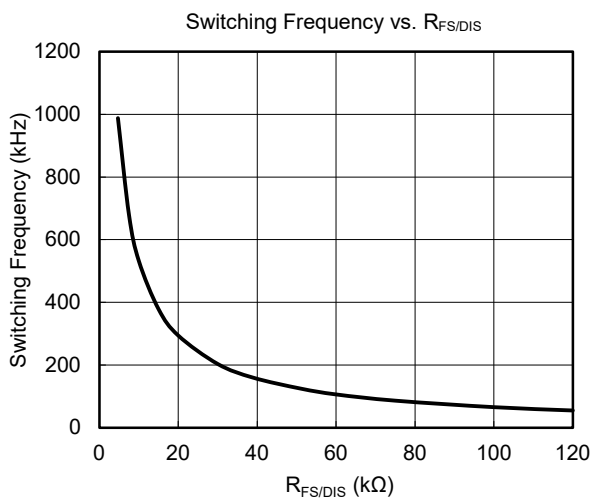

# AAP6013A 7.5V to 36V Input Supply, CC/CV Synchronous Buck PWM Converter with Adjustable Switching Frequency

## FUNCTIONAL BLOCK DIAGRAM

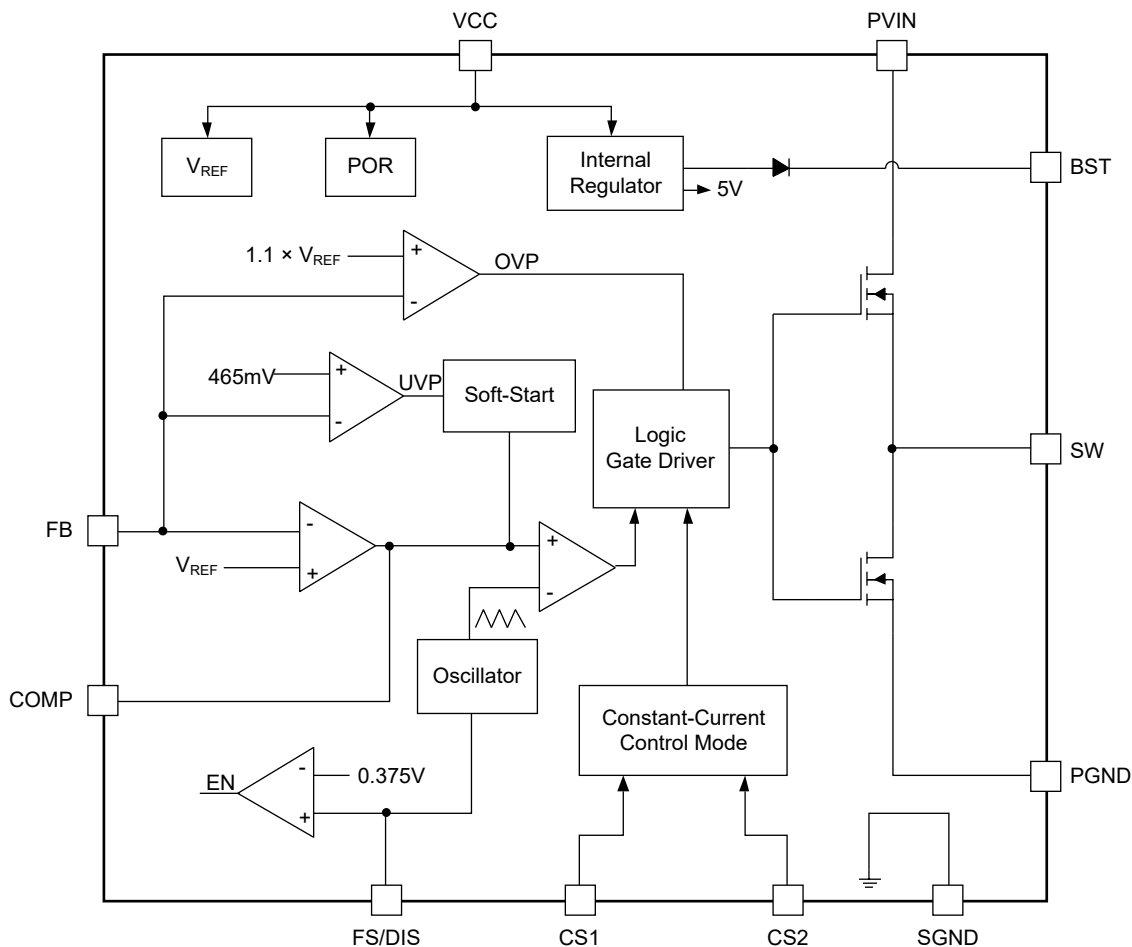

Figure 2. Block Diagram

## DETAILED DESCRIPTION

The AAP6013A is a voltage mode synchronous buck PWM converter with programmable dual-output CC/CV control.

### Initialization

The AAP6013A creates its own internal supplies for use. The POR function continually monitors the input bias supply voltage at the VCC pin. The POR function initiates soft-start operation after VCC supply voltage exceeds its POR rising threshold voltage.

### Soft-Start

The AAP6013A has an internal soft-start circuitry to reduce supply inrush current during startup conditions. The typical soft-start time is about 3ms. The power-on reset function initiates the soft-start process. Once the VCC voltage falls below 6V, the device will shut down until the voltage exceeds 7V again.

# 7.5V to 36V Input Supply, CC/CV Synchronous Buck PWM AAP6013A Converter with Adjustable Switching Frequency

## DETAILED DESCRIPTION (continued)

### Switch Frequency and Disable

FS/DIS pin has two functions. A resistor is connected to the SGND pin to set the internal oscillator frequency for the switching regulator. In addition, if this pin is pulled down towards SGND with low impedance, it will disable the DC/DC regulator until it released (at which time a new soft-start cycle will begin). If the FS/DIS pin is floating, the device is also shutdown.

**Table 1. Compensation Values for Typical Switching Frequency Combinations**

f <sub>SW</sub> (kHz)	L (μH)	C <sub>OUT</sub> (μF)	C <sub>1</sub> (pF)	R <sub>COMP</sub> (kΩ)	C <sub>2</sub> (nF)	C <sub>3</sub> (pF)
50	22	220	100	39	10	47
100	22	220	100	39	10	47
200	15	220	100	51	6.8	47
300	10	220	100	68	4.7	22
400	6.8	220	100	75	3.3	22
500	5.5	220	100	82	2.2	22
600	4.7	220	100	87	2.2	15
700	3.3	220	100	91	2.2	15
800	2.2	220	100	100	1	15

### CC/CV Control and Output Short Protection

When the load current is less than the current limit, the AAP6013A will regulate the output voltage and operate in the constant-voltage (CV) control mode. If the load current increases and reaches the current-limit point sensed by the CS1 or CS2 pin, then the AAP6013A will enter the constant-current (CC) control mode, and the output voltage will decrease. If the FB pin voltage is lower than 465mV, the device will stop switching for a long time before initiating a new soft-start cycle. If the output over-current condition or output short condition is not removed, the converter will enter hiccup mode. By this long time sleeping at over-current condition or output under-voltage condition, the input current of the system is nearly zero.

If the output voltage is shorted directly to ground, a low-side switch current-limit function will take over. It is realized by sensing the current through the low-side switch after a blanking time (200ns TYP) when low-side switch turns on. If the current is larger than 17A, the high-side MOSFET will skip turning on for at least 3 cycles and the low-side switch will remain on until the current is less than 17A.

### OVP and Thermal Shutdown

If the FB pin voltage is higher than  $1.1 \times V_{REF}$ , the AAP6013A will immediately stop switching, and the device will not open the high-side MOSFET until the output voltage decreases to regulation target.

Over temperature protection limits total power dissipation in the device. When the junction temperature exceeds +150°C, a thermal sensor forces the device into shutdown, allowing the die to cool. The thermal sensor turns the device on again after the junction temperature cools by 15°C.

### BST Capacitor, Bootstrap Refresh

A capacitor from the SW pin to the BST pin is required for the bootstrap circuit for the high-side gate driver. The voltage of the SW pin can go as high as the supply voltage during the high-side MOSFET opens. A diode is included on the IC (anode to internal 5V VCC, cathode to BST pin), such that the VCC will be the bootstrap supply. At no load or very light load condition, high-side and low-side MOSFETs are both off for a long time. There is no charging path to the bootstrap capacitor because the switch node voltage is equal to V<sub>OUT</sub> (5V, TYP). The bootstrap capacitor loses energy and its voltage will go down. The AAP6013A has a charge mode which can let the system work properly at very light load condition: if the device stops switching for 32 cycles after zero cross current detection, it will force low-side MOSFET to turn on for 250ns, and then switch node voltage will go down to the ground so that bootstrap capacitor can be charged again.

### Pre-biased Startup

The device is designed for safe monotonic startup into pre-biased loads.



# 7.5V to 36V Input Supply, CC/CV Synchronous Buck PWM Converter with Adjustable Switching Frequency

## AAP6013A

### APPLICATION INFORMATION

#### Setting Output Voltages

Output voltage is set by external resistors. The  $V_{REF}$  is 0.8V.  $V_{OUT}$  can be calculated as:

$$V_{OUT} = V_{REF} \times \left(1 + \frac{R_1}{R_2}\right) \quad (1)$$

The output voltage of the regulator is determined by an external resistor divider from the output node to the FB pin as shown in Figure 3.

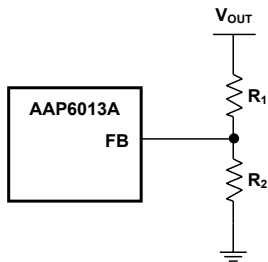

Figure 3. Setting  $V_{OUT}$  with an External Resistor Divider

#### Setting Constant-Current Threshold

The output constant-current value is set by a sense resistor between CS1 or CS2 pin and PGND, according to the following equation:

$$I_{CC} = \frac{84\text{mV}}{R_{CS}} \quad (2)$$

#### Output Cable Compensation

Output cable compensation voltage can be set by  $R_1$  in Figure 3.

$$V_{CS} = I_{OUT} \times R_{CS} \quad (3)$$

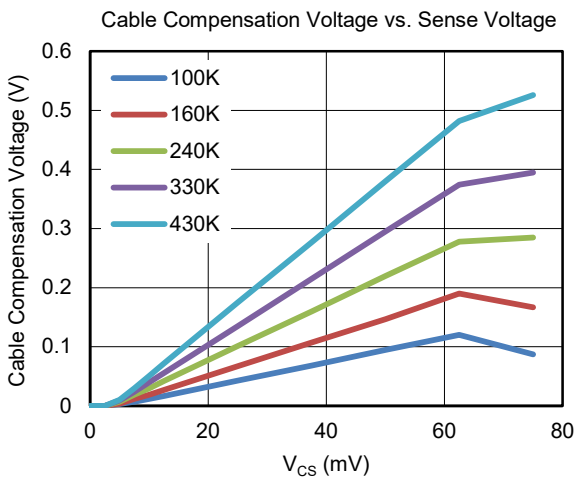

Figure 4. Setting Cable Compensation ( $V_{CS} = \text{Max}[V_{CS1}, V_{CS2}]$ )

#### Inductor Selection

The required external components for the step-down are an inductor, input and output filter capacitors, and compensation RC network. The AAP6013A provides best efficiency with continuous inductor current. A reasonable inductor value ( $L_{IDEAL}$ ) can be derived from the following:

$$L_{IDEAL} = \frac{V_{IN} \times D \times (1-D)}{f_{SW} \times I_{OUT} \times K_{RIPPLE}} \quad (4)$$

where  $K_{RIPPLE}$  is the ratio of the peak-to-peak inductor current to the inductor DC current. Usually, we set  $K_{RIPPLE}$  between 10% ~ 30%.  $D$  is the duty cycle:

$$D = \frac{V_{OUT}}{V_{IN}} \quad (5)$$

Given  $L_{IDEAL}$ , the peak-to-peak inductor current is  $K_{RIPPLE} \times I_{OUT}$ . The absolute-peak inductor current is  $I_{OUT} \times (1 + 0.5K_{RIPPLE})$ . Inductance values smaller than  $L_{IDEAL}$  can be used to reduce inductor size; however, if much smaller values are used, inductor current rises, and larger output capacitance may be required to suppress output ripple. Larger values than  $L_{IDEAL}$  can be used to obtain higher output current, but typically with larger inductor size.

#### Output Capacitor Selection

The output capacitor is determined by the required ESR to minimize voltage ripple. Moreover, the amount of bulk capacitance is also a key for  $C_{OUT}$  selection to ensure that the control loop is stable. The 220 $\mu$ F polymer output capacitors are suggested to be used in most applications. Loop stability can be checked by viewing the load transient response.

The output ripple is given by:

$$\Delta V_{OUT} \leq \Delta I_L \left( R_{ESR} + \frac{1}{8f_{SW} C_{OUT}} \right) \quad (6)$$

The output ripple will be the highest at maximum input voltage since  $\Delta I_L$  increases with input voltage. Multiple capacitors placed in parallel may be needed to meet the ESR and RMS current handling requirement.

## **APPLICATION INFORMATION (continued)**

### **Input Capacitor Selection**

The input capacitor needs to be carefully selected to maintain sufficiently low ripple at the supply input of the converter. A low ESR capacitor is highly recommended. Since large current flows in and out of this capacitor during normal switching, its ESR also affects efficiency. Use small ceramic capacitors (CHF) for high frequency decoupling and bulk capacitors to supply the surge current needed each time high-side MOSFET turns on.

Place the small ceramic capacitors physically close to the PVIN and PGND pins.

The input buck capacitors should also be placed close to the PVIN pins with the shortest layout traces to the ground connections. The important parameters for the buck input capacitors are the voltage rating and the RMS current rating. For reliable operation, select the bulk capacitor with voltage and current ratings above the maximum input voltage and largest RMS current required by the circuit. The capacitor voltage rating should be at least 1.25 times greater than the maximum input voltage and a voltage rating of 1.5 times is a conservative guideline.

The RMS current is given by:

$$I_{\text{RMS}} = I_{\text{OUT}} \times \frac{V_{\text{OUT}}}{V_{\text{IN}}} \sqrt{\frac{V_{\text{IN}}}{V_{\text{OUT}}} - 1} \quad (7)$$

$I_{\text{RMS}}$  has a maximum at  $V_{\text{IN}} = 2V_{\text{OUT}}$ , where  $I_{\text{RMS}} = I_{\text{OUT}}/2$ . This simple worst-case condition is commonly used for design because even significant deviations do not offer much relief.

### **EMI Consideration**

Since parasitic inductance and capacitance effects in PCB circuitry would cause a spike voltage on SW node when high-side MOSFET is turned on/off, this spike voltage on SW pin may impact on EMI performance in the system. In order to enhance EMI performance, there are two methods to suppress the spike voltage. One is to place an RC snubber between SW and GND and make them as close as possible to the high-side MOSFET's source and low-side MOSFET's drain. Another method is to add a resistor in series with the bootstrap capacitor  $C_1$ . But this method will decrease the driving capability to the high-side MOSFET. It is strongly recommended to reserve the RC snubber during PCB layout for EMI improvement. Moreover, reducing the SW trace area and keeping the main power in a small loop will be helpful on EMI performance.

# 7.5V to 36V Input Supply, CC/CV Synchronous Buck PWM AAP6013A Converter with Adjustable Switching Frequency

## PCB LAYOUT GUIDE

When doing the PCB layout, some critical considerations should be taken to ensure proper operation and the best performance of the AAP6013A. Below are the rules of thumb for AAP6013A PCB layout.

The input power path including the PVIN, SW and the PGND traces should be as short as possible, direct and wide. So the input capacitors (C<sub>2</sub> and C<sub>3</sub>) are placed as close to PVIN pins of the device as possible, thus the input loop length/area shaped by C<sub>2</sub>, C<sub>3</sub>, PVIN pins and PGND pins are the shortest/smallest respectively.

The output power path between the SW pins of the AAP6013A, the power inductor L<sub>1</sub> and the output capacitors (C<sub>4</sub> and C<sub>5</sub>) should be kept short and wide.

Keep the switching node SW away from the sensitive pins such as FB, COMP, CS1 and CS2 of the AAP6013A. The external components of FB, COMP, CS1 and CS2 of the device are placed at the opposite side of the power inductor L<sub>1</sub>.

Keep the snubbed circuit R<sub>9</sub> and C<sub>11</sub> to the SW pins of the AAP6013A as close as possible.

Keep the SW trace as physically short and wide as practical to minimize radiated emissions.

Use Kelvin sense connection techniques from the sensing resistor (R<sub>1</sub>/R<sub>2</sub>) pads directly to the CS1/CS2 and SGND pins to achieve accurate CC limit.

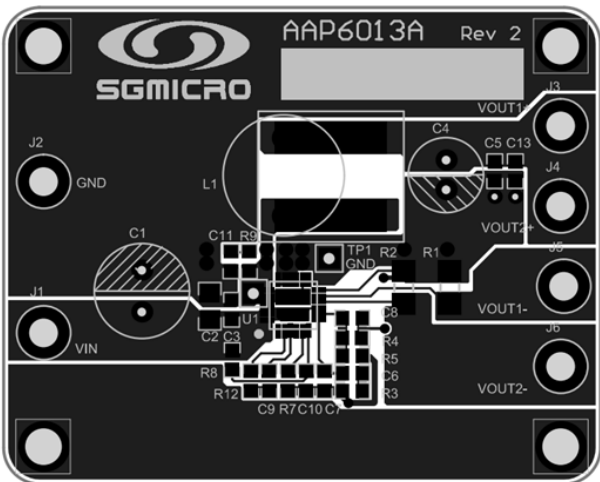

Figure 5. PCB Top Layer

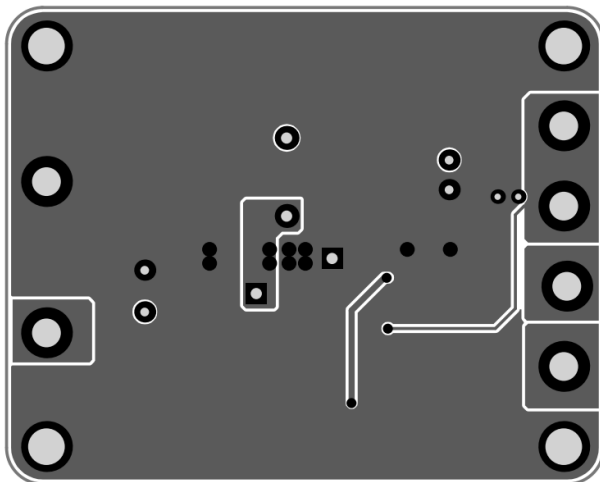

Figure 6. PCB Bottom Layer

# 7.5V to 36V Input Supply, CC/CV Synchronous Buck PWM Converter with Adjustable Switching Frequency

## AAP6013A

### TYPICAL APPLICATION CIRCUITS

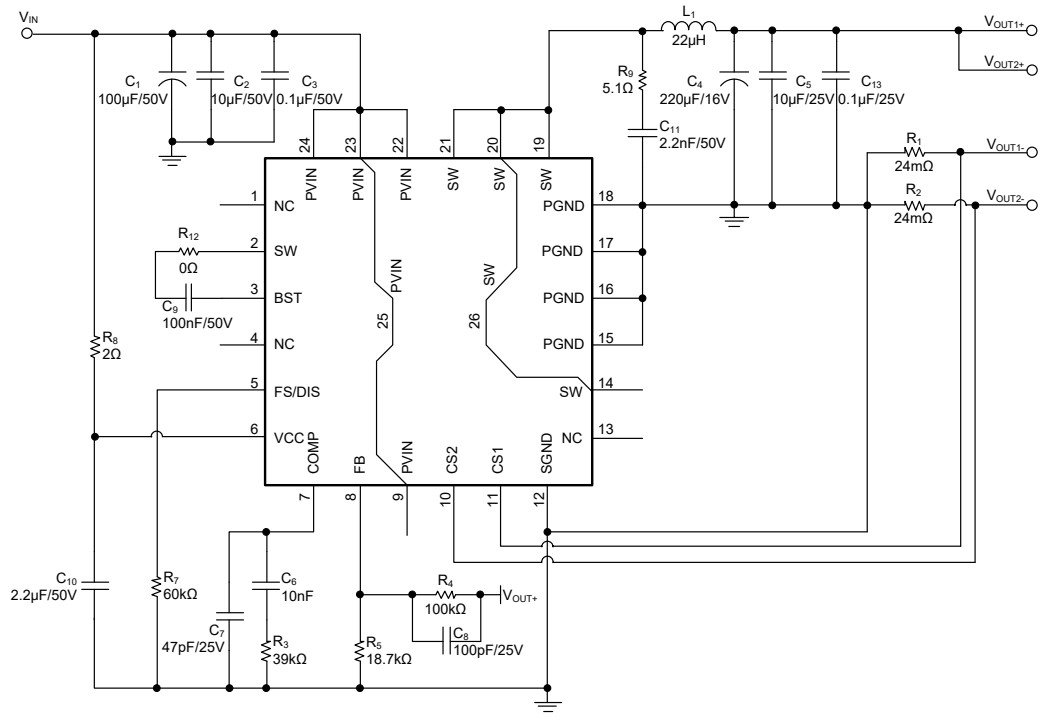

Figure 7. AAP6013A Typical Application Example for 100kHz 5V/3A + 5V/3A Dual Outputs

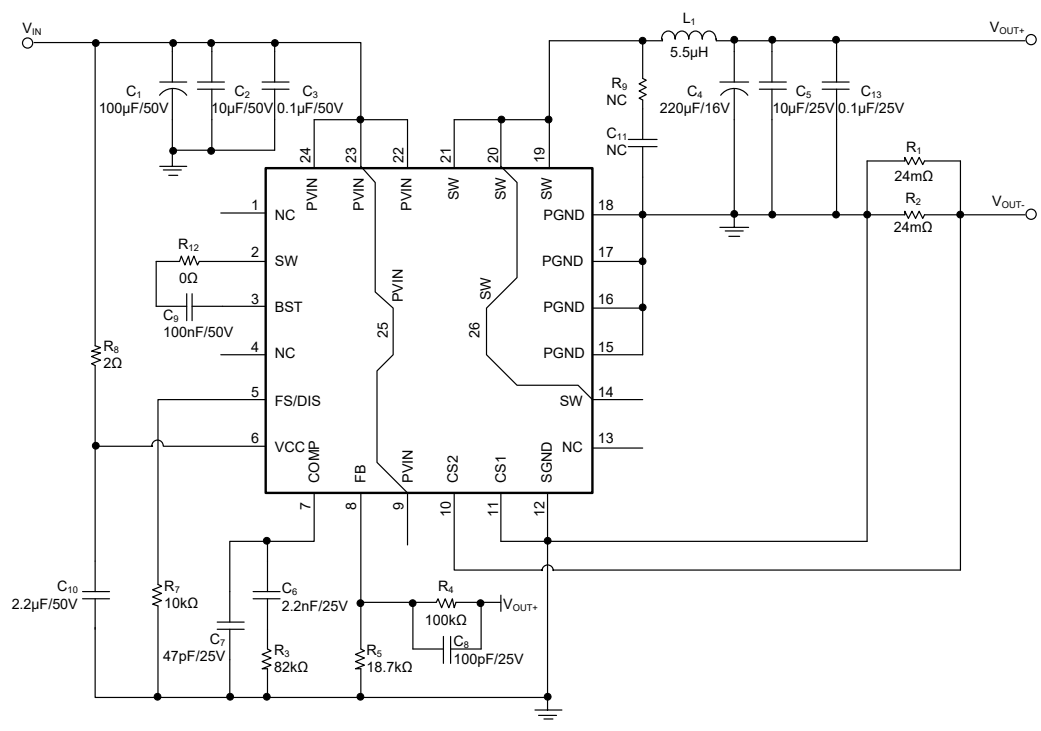

Figure 8. AAP6013A Typical Application Example for 500kHz 5V/6A Single Output

## REVISION HISTORY

NOTE: Page numbers for previous revisions may differ from page numbers in the current version.

### Changes from Original (DECEMBER 2020) to REV.A

---

Changed from product preview to production data.....	All
--	-----

---

## PACKAGE OUTLINE DIMENSIONS

### TQFN-4x4-24BL

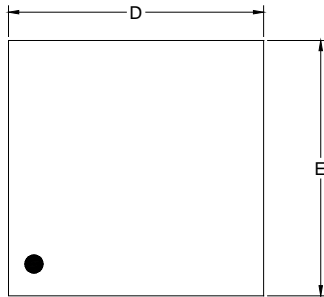

TOP VIEW

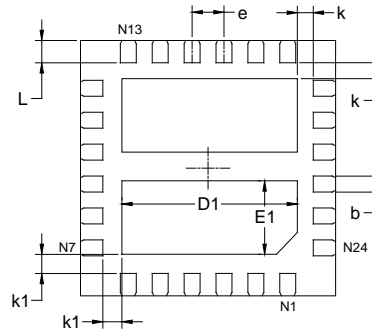

BOTTOM VIEW

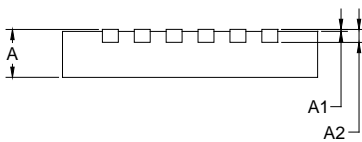

SIDE VIEW

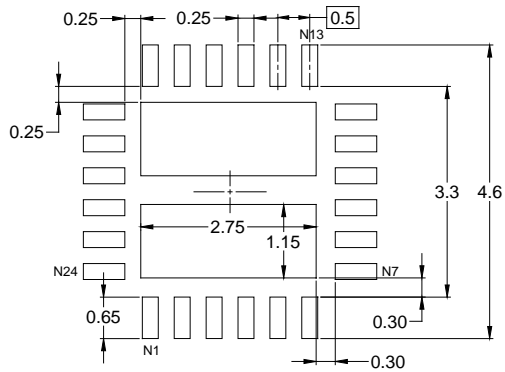

RECOMMENDED LAND PATTERN (Unit: mm)

Symbol	Dimensions In Millimeters		
	MIN	MOD	MAX
A	0.7	0.75	0.8
A1	0	0.02	0.05
A2	0.203 REF		
b	0.2	0.25	0.3
D	4 BSC		
E	4 BSC		
D1	2.65	2.75	2.85
E1	1.05	1.15	1.25
L	0.25	0.35	0.45
e	0.5 BSC		
k	0.25 REF		
k1	0.3 REF		

TAPE AND REEL INFORMATION

REEL DIMENSIONS



TAPE DIMENSIONS



NOTE: The picture is only for reference. Please make the object as the standard.

KEY PARAMETER LIST OF TAPE AND REEL

Package Type	Reel Diameter	Reel Width W1 (mm)	A0 (mm)	B0 (mm)	K0 (mm)	P0 (mm)	P1 (mm)	P2 (mm)	W (mm)	Pin1 Quadrant
TQFN-4×4-24BL	13"	12.4	4.30	4.30	1.10	4.0	8.0	2.0	12.0	Q2

000001

# PACKAGE INFORMATION

## CARTON BOX DIMENSIONS



NOTE: The picture is only for reference. Please make the object as the standard.

## KEY PARAMETER LIST OF CARTON BOX

Reel Type	Length (mm)	Width (mm)	Height (mm)	Pizza/Carton
13"	386	280	370	5

DD0002