

THIS DRAWING IS UNPUBLISHED. RELEASED FOR PUBLICATION 2016
 © COPYRIGHT 2016 BY TE CONNECTIVITY SHANGHAI, CHINA ALL RIGHTS RESERVED.

REVISIONS					
P	LTR	DESCRIPTION	DATE	DWN	APVD
	A	NEW DRAWING	28MAR2017	F.Y	I.Y

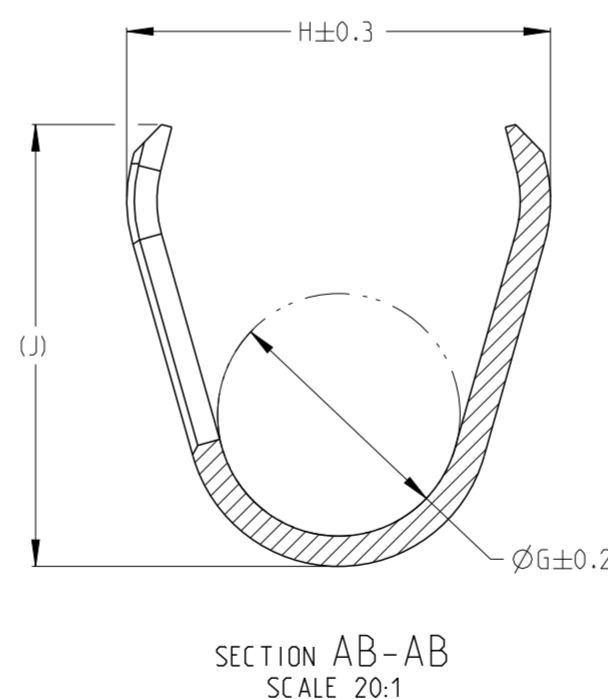

- NOTES:
1. TERMINALS DESIGNED TO BE USED WITH FLR CABLE.
 2. MAX. 9 TERMINALS MISSING PER REEL PERMITTED.
 3. 3 LOOSE SPLICES PER REEL PERMITTED.

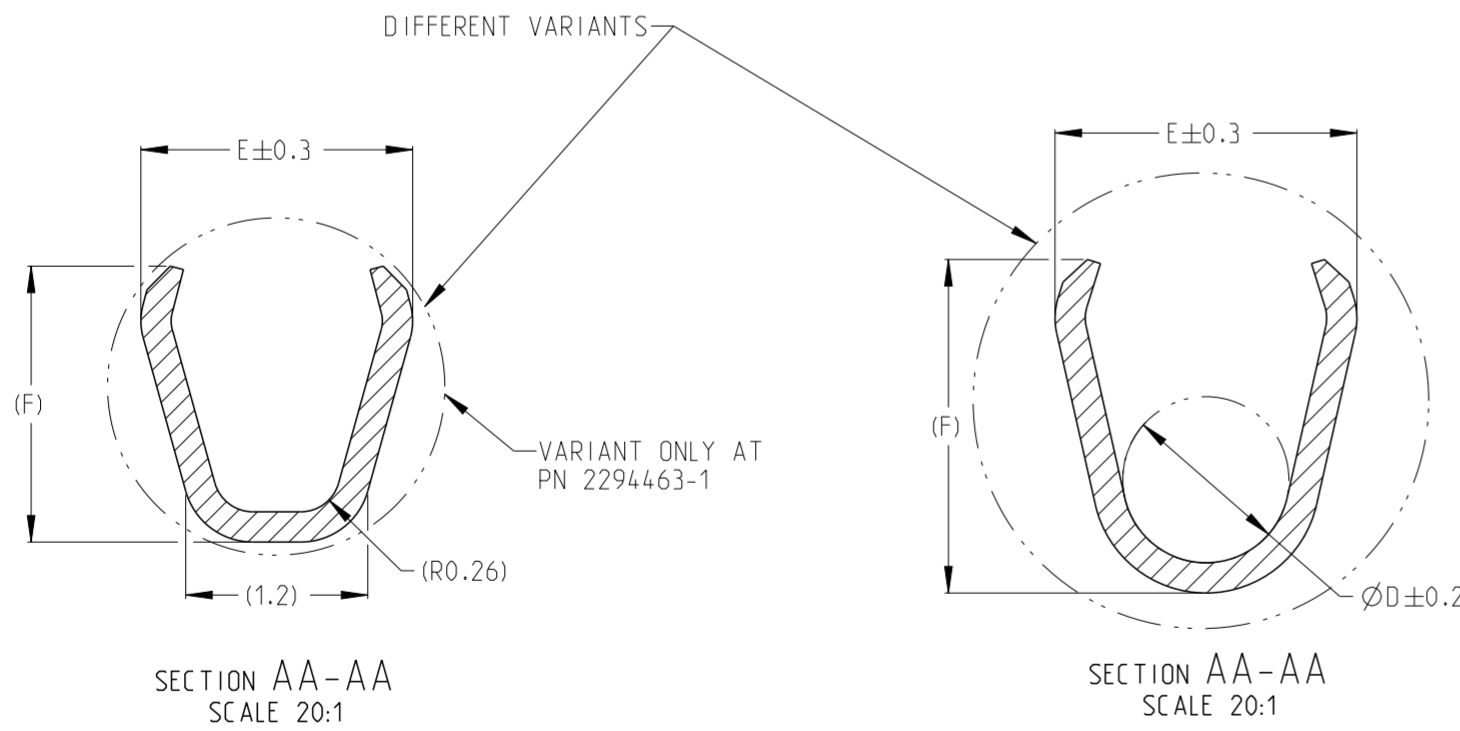
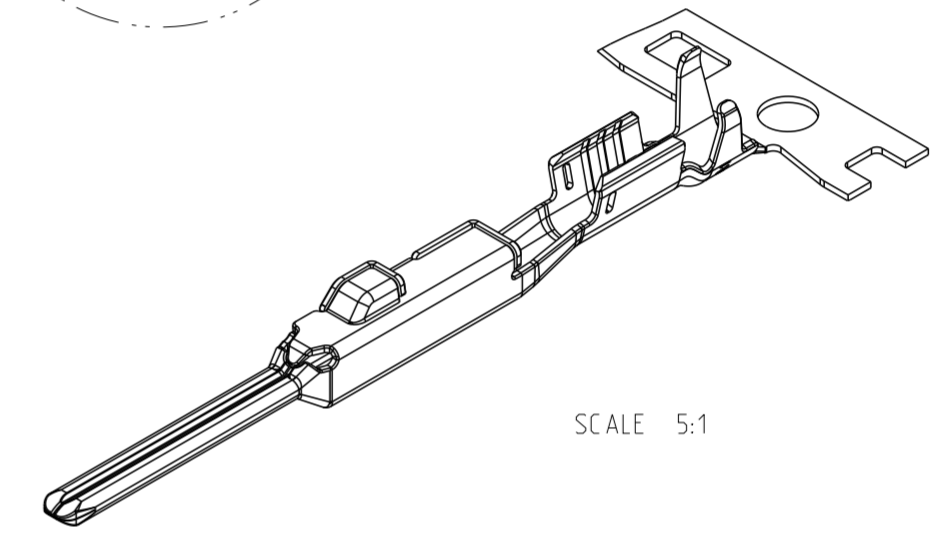
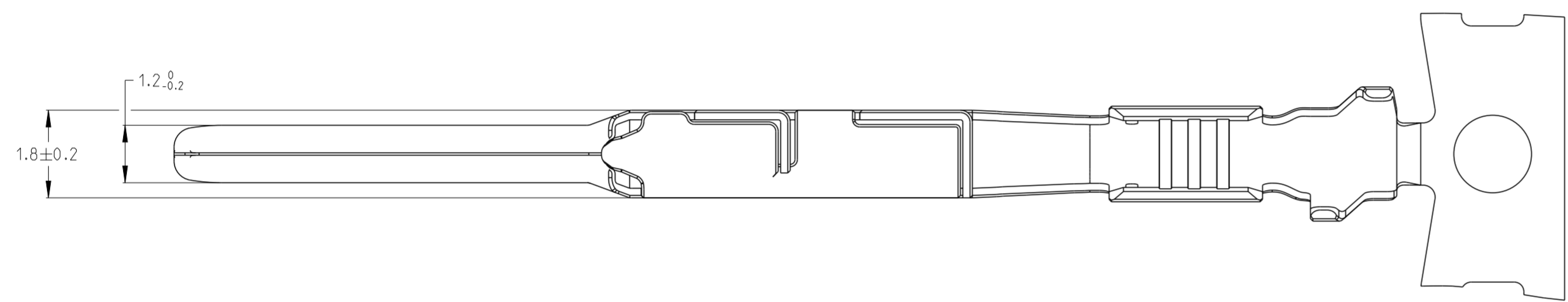
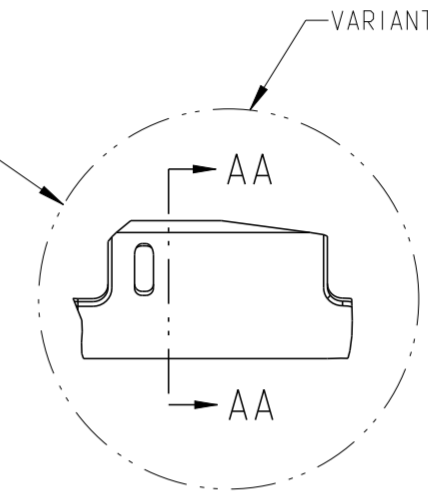
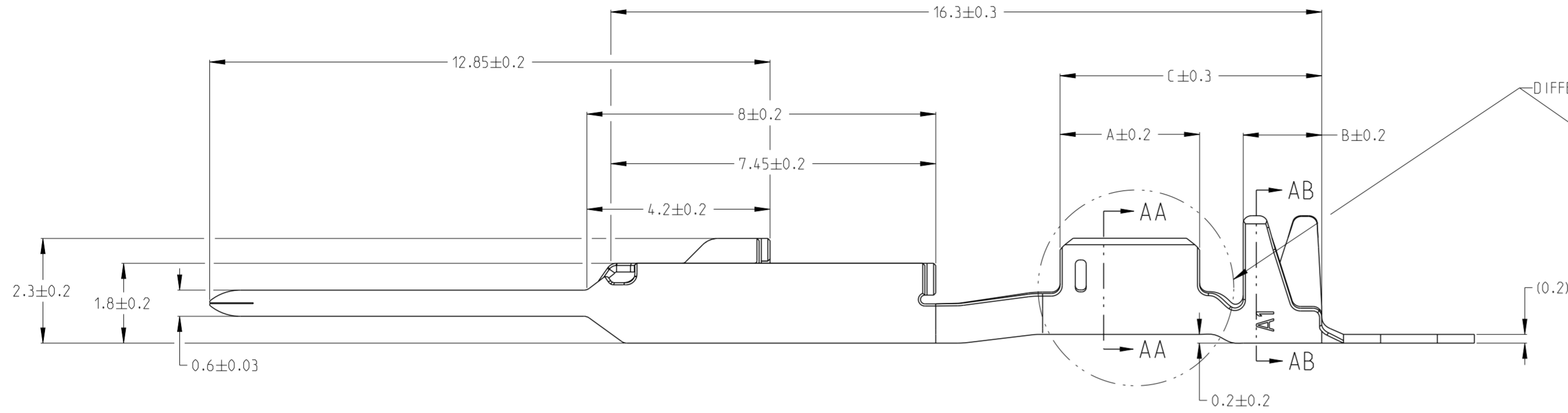
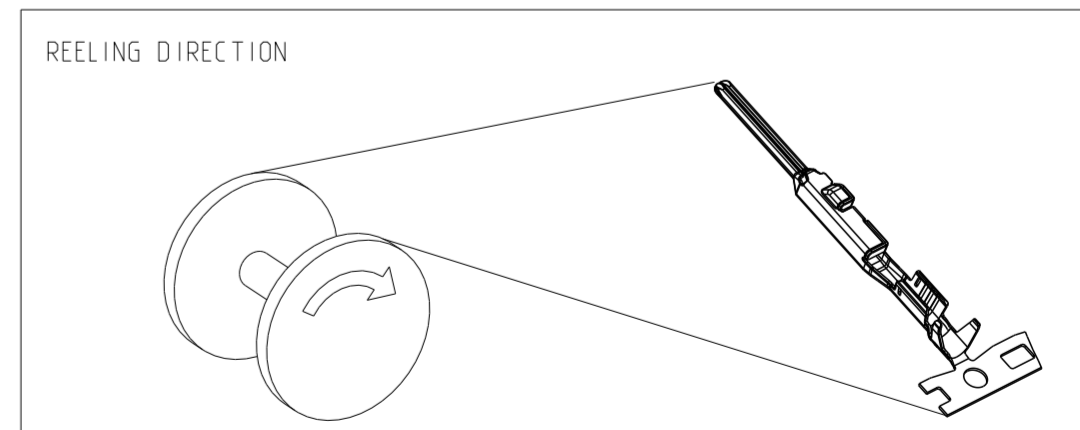

2294463-3	A	1.0~1.5mm ²	1.9~2.4	BRASS	PRE-TIN	3.4	2.0	6.4	1.5	2.7	2.8	2.25	3.6	3.7
2294463-2	A	0.5~0.75mm ²	1.4~1.9	BRASS	PRE-TIN	3.2	1.8	6.0	1.1	2.0	2.2	1.6	2.8	2.9
2294463-1	A	0.22~0.35mm ²	1.1~1.4	BRASS	PRE-TIN	2.9	2.0	6.0	-	1.8	1.8	1.3	2.35	2.5
PART NUMBER	REVISION	WIRE RANGE	INSULATION-Ø	MATERIAL	FINISH	A	B	C	D	E	F	G	H	J
						LENGTH			WIRE CRIMP			INSULATION CRIMP		

DIMENSIONS:		TOLERANCES UNLESS OTHERWISE SPECIFIED:	
mm			
		0 PLC	±
		1 PLC	±
		2 PLC	±
		3 PLC	±
		4 PLC	±
		ANGLES	±
		FINISH	±

THIS DRAWING IS A CONTROLLED DOCUMENT.		DWN	F.YU	28MAR2017	 TE Connectivity
		CHK	W_ZHANG	28MAR2017	
		APVD	J.YIN	28MAR2017	
		NAME			
		PRODUCT SPEC			108-101426
		APPLICATION SPEC			114-101043
		WEIGHT			-
		CUSTOMER DRAWING			SCALE 10:1 SHEET 1 OF 1 REV A