

LOC	DIST	REVISIONS					
		P	LTR	DESCRIPTION	DATE	DWN	APVD
DS	-		A	RELEASE	09APR'09	SH	JK
			B	REVISED (ECR-10-002760)	16MAR'10	SH	JK

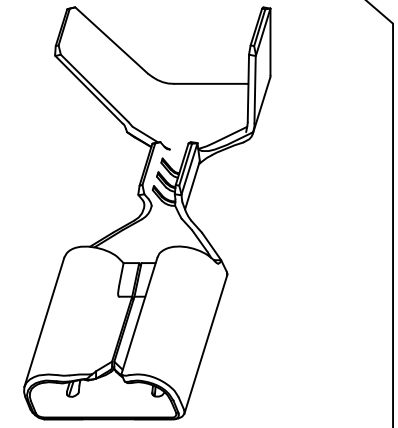

ISD VIEW
SCALE 3:1

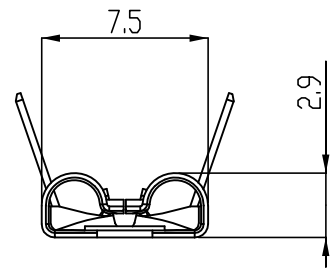
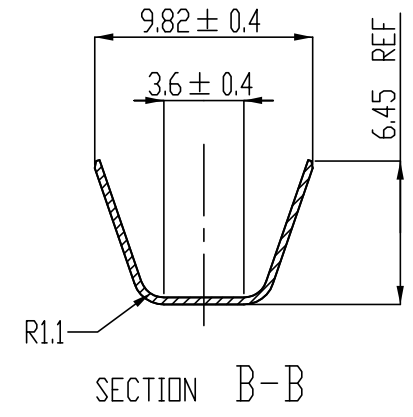
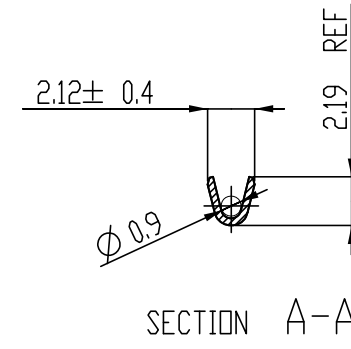
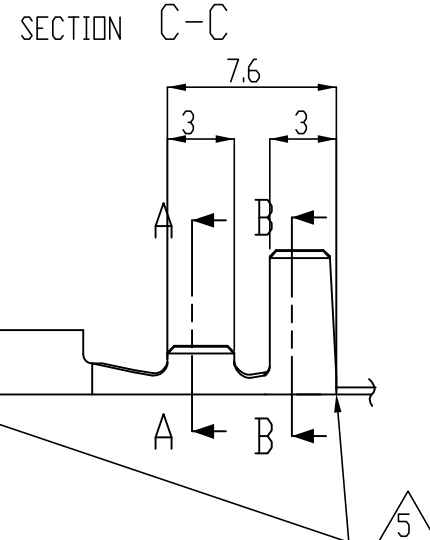
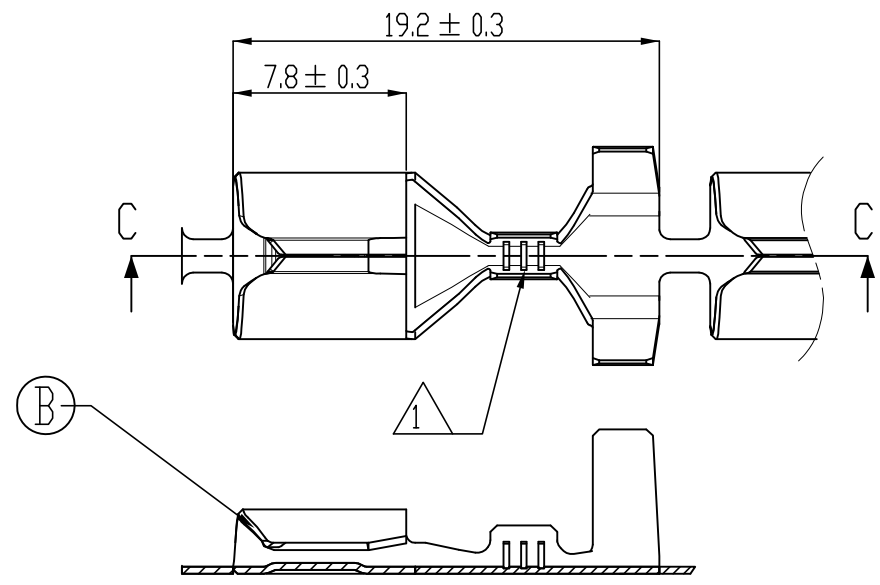
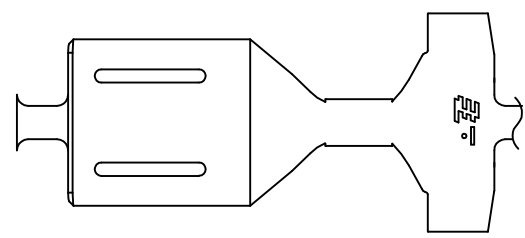

NOTES;

- 1. THREE SERRATIONS WERE CENTERED IN WIRE BARREL
- 2. WIRE SIZE EQUIV AESSXF 0.3~ AEXF 0.5 sqmm
- 3. TOLERANCES UNLESS OTHERWISE SPECIFIED : ±0.2, ±3°
- 4. MUST BE REFERRED TO THE FOLLOWING TABLE 1 FOR CRIMPING OPERATION.
- 5. 0.5 Max Cutoff Tab, with 0.15 Max Burr(Front and Rear)

<small>THIS DRAWING IS A CONTROLLED DOCUMENT FOR TYCO ELECTRONICS CORPORATION IT IS SUBJECT TO CHANGE AND THE CONTROLLING ENGINEERING ORGANIZATION SHOULD BE CONTACTED FOR THE LATEST REVISION.</small>	
DIMENSIONS: mm	TOLERANCES UNLESS OTHERWISE SPECIFIED:
	0 PLC ±
	1 PLC ±0.5
	2 PLC ±0.13
	3 PLC ±0.013
	4 PLC ±0.0001
	ANGLES ±
MATERIAL -	FINISH -

PRE-TINNED	CuNiSi Alloy 0.32THK	1897659-1
FINISH	MATERIAL	PART NUMBER
DWN SH LEE	Tyco Electronics Kyungsan, Korea.	NAME
CHK KT LIM		
APVD JK SONG	250 SERIES FASTON RECEPTACLE	
PRODUCT SPEC 108-61108	SIZE	CAGE CODE
APPLICATION SPEC 114-61026	A3	00779
WEIGHT	DRAWING NO	RESTRICTED TO
CUSTOMER DRAWING	©=1897659	-
SCALE 3:1	SHEET 1 OF 2	REV B

THIS DRAWING IS UNPUBLISHED. RELEASED FOR PUBLICATION
 © COPYRIGHT BY TYCO ELECTRONICS CORPORATION. ALL RIGHTS RESERVED.

LOC	DIST	REVISIONS					
		P	LTR	DESCRIPTION	DATE	DWN	APVD
DS							

TABLE 1

Wire Size(mm ²)	Wire Strip Length	Wire Crimp				Insulation Crimp	
		Width	Height	Form	Area index(%)	Width	Form
AVSF,AVXF,AEXF 0.3(0.3054)	4.3	1.4	1.13 ± 0.03	F	75.29~84.87	7.0	F
AVSS,AVX,AEX 0.3(0.3716)							
AESSXF,AVSSF 0.3(0.382)							
TXL 0.35(0.324)							
FLR 0.35(0.4156)							
FLX,FLY 0.5(0.5027)			1.23 ± 0.03				
TXL,AVSF,AEXF 0.5(0.5089)							
AESSXF,FLR,AVSSF 0.5(0.5389)							
AVSS, AEX, CAVS 0.5(0.563)							

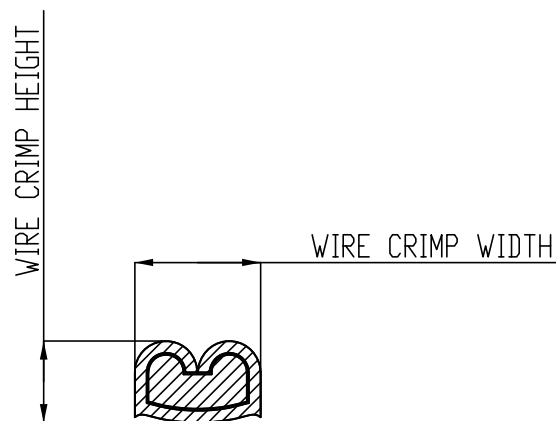

<small>THIS DRAWING IS A CONTROLLED DOCUMENT FOR TYCO ELECTRONICS CORPORATION IT IS SUBJECT TO CHANGE AND THE CONTROLLING ENGINEERING ORGANIZATION SHOULD BE CONTACTED FOR THE LATEST REVISION.</small>		DWN	Tyco Electronics Kyungsan, Korea.			
DIMENSIONS:		CHK	NAME			
		APVD	250 SERIES FASTON RECEPTACLE			
		PRODUCT SPEC				
<small>TOLERANCES UNLESS OTHERWISE SPECIFIED:</small> 0 PLC ± 1 PLC ± 2 PLC ± 3 PLC ± 4 PLC ± ANGLES ±		APPLICATION SPEC	SIZE	CAGE CODE	DRAWING NO	RESTRICTED TO
		MATERIAL	FINISH	WEIGHT	A3	1897659
CUSTOMER DRAWING			SCALE	SHEET 2 OF 2	REV B	