

THIS DRAWING IS UNPUBLISHED. RELEASED FOR PUBLICATION 20  
 © COPYRIGHT 20 BY TYCO ELECTRONICS CORPORATION ALL RIGHTS RESERVED.

| REVISIONS |     |                         |          |       |
|-----------|-----|-------------------------|----------|-------|
| P         | LTR | DESCRIPTION             | DATE     | APVD  |
| A         |     | REVISED (FC00-0030-05)  | 25JAN'05 | YD CS |
| B         |     | REVISED (ECR-10-024376) | 08DEC'10 | SJ HG |
| B1        |     | REVISED (ECR-17-016653) | 13NOV'17 | HH YJ |
| B2        |     | REVISED (ECR-22-150596) | 26AUG'22 | DG YJ |

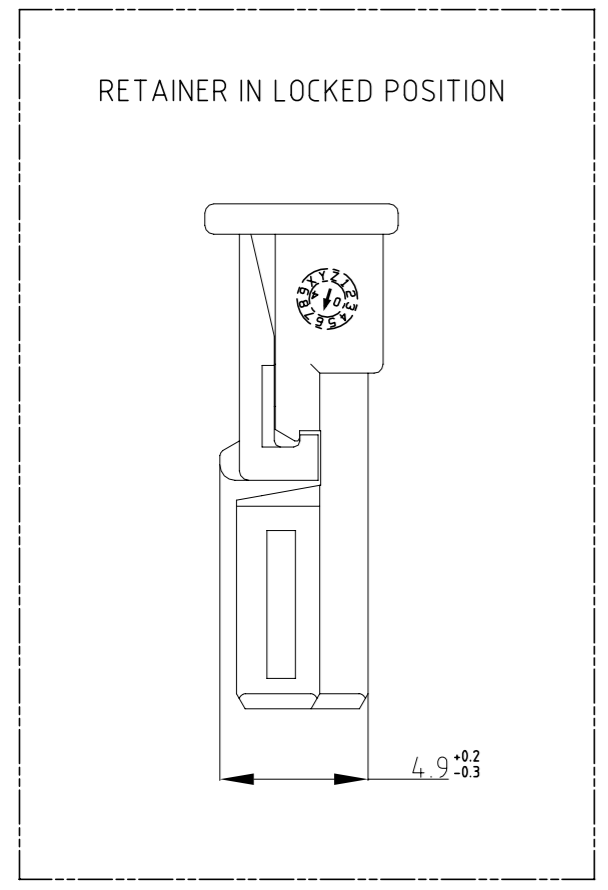
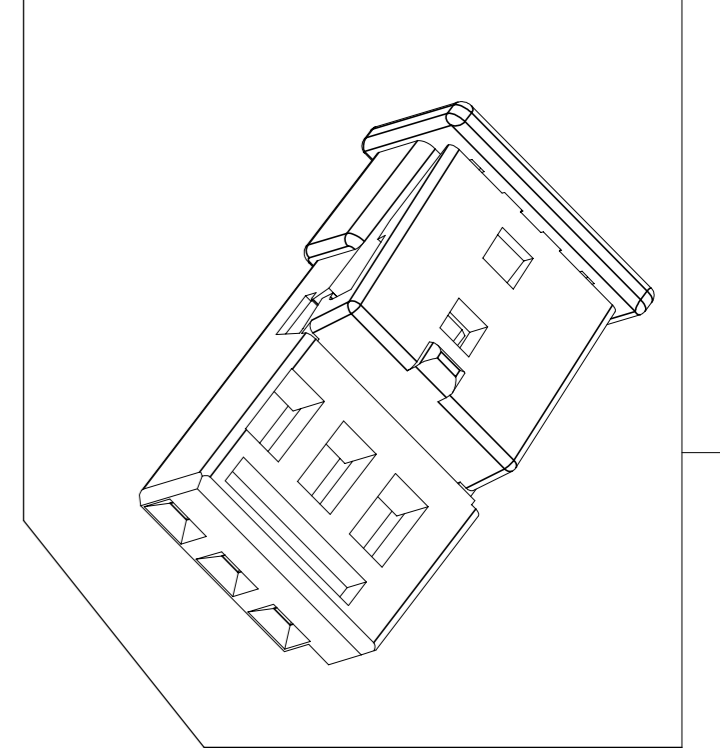
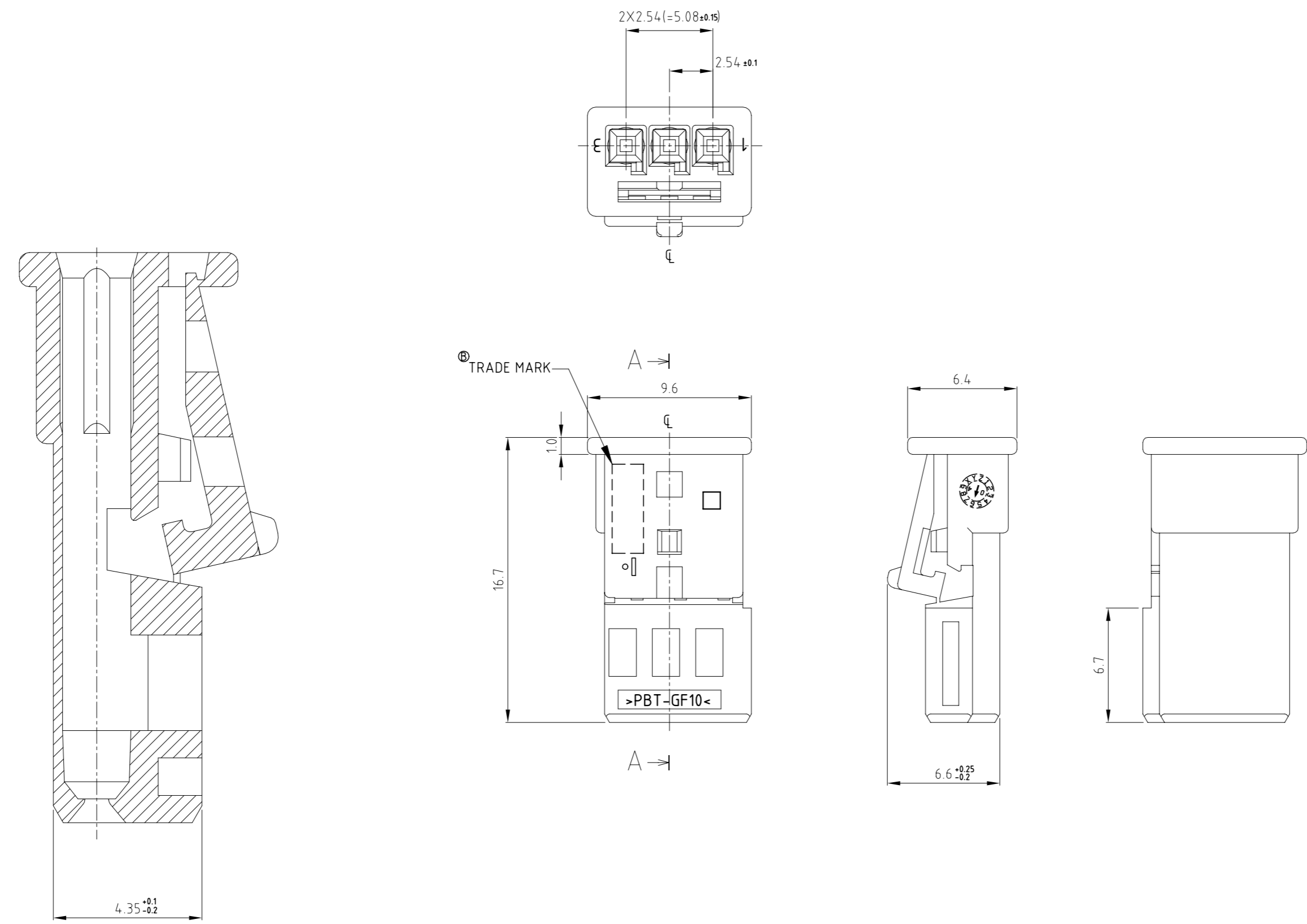

SECTION A-A  
SCALE 8:1

- NOTES
- GENERAL TOLERANCE : DIMENSION  $\pm 0.3$  ANGLE  $\pm 3^\circ$
  - SUITABLE FOR WIRE SIZE RANGE : 0.2-0.75mm<sup>2</sup>
  - CONDITION AS DELIVERY : RETAINER IN PRE-LOCKED POSITION
  - SUITABLE FOR PIN HEADER ASS'Y HSG : P/N X-1743156-X
  - APPLICABLE RECEPTACLE CONTACT P/N ;

| WIRE SIZE (mm <sup>2</sup> ) | 0.2 - 0.5  | 0.75       |
|------------------------------|------------|------------|
| (B2) PART NO.                | 5-928999-X | 5-963715-X |

| (B1) | 0-1743164-7 | MQS PLUG HOUSING, 3POS | PBT-GF10 | GREEN   |
|------|-------------|------------------------|----------|---------|
|      | 0-1743164-2 | MQS PLUG HOUSING, 3POS | PBT-GF10 | BLACK   |
| (A)  | 0-1743164-1 | MQS PLUG HOUSING, 3POS | PBT-GF10 | NATURAL |
|      | PART NO.    | DESCRIPTION            | MATERIAL | COLOR   |

|   |  |                   |                               |                          |                    |                 |           |
|---|--|-------------------|-------------------------------|--------------------------|--------------------|-----------------|-----------|
| THIS DRAWING IS A CONTROLLED DOCUMENT.                  |  | DWN<br>S.J. CHOI  | TE Connectivity               |                          |                    |                 |           |
| DIMENSIONS:<br>MM                                       |  | CHK<br>J.W. JUNG  |                               |                          |                    |                 |           |
| TOLERANCES UNLESS OTHERWISE SPECIFIED:<br><br>SEE NOTES |  | APVD<br>H.G. CHO  | NAME<br>MQS LUG HOUSING, 3POS |                          |                    |                 |           |
| MATERIAL<br>SEE TABLE                                   |  | FINISH<br>-       | WEIGHT<br>-                   | SIZE<br>A2               | CAGE CODE<br>00779 |                 |           |
|   |  | PRODUCT SPEC<br>- | APPLICATION SPEC<br>-         | DRAWING NO.<br>C-1743164 | RESTRICTED TO<br>- |                 |           |
|   |  | CUSTOMER DRAWING  |                               |                          | SCALE<br>2:1       | SHEET<br>1 OF 1 | REV<br>B2 |