

THIS DRAWING IS UNPUBLISHED. RELEASED FOR PUBLICATION  
 © COPYRIGHT - By - ALL RIGHTS RESERVED.

LOC	DIST	REVISIONS					
CM	00	P	LTR	DESCRIPTION	DATE	DWN	APVD
		B1		REVISED PER ECO-11-004820	11MAR11	RK	HMR

- 1 WIRE RANGE: 0.2-0.8mm<sup>2</sup> (24-18 AWG).
- 2 INSULATION RANGE: 1.5-2.4 DIA.
- 3 FINISH: 0.76μm MIN GOLD OVER 1.27μm MIN NICKEL REQUIRED ON INNER SURFACE, PERMITTED ON OUTER SURFACE.
- 4 FINISH: 2.54μm MIN TIN ON ALL SURFACES IN THIS AREA.

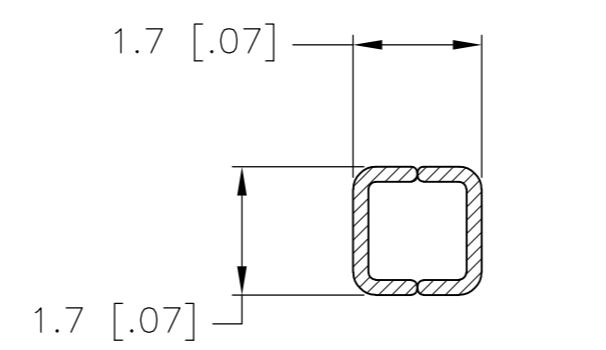
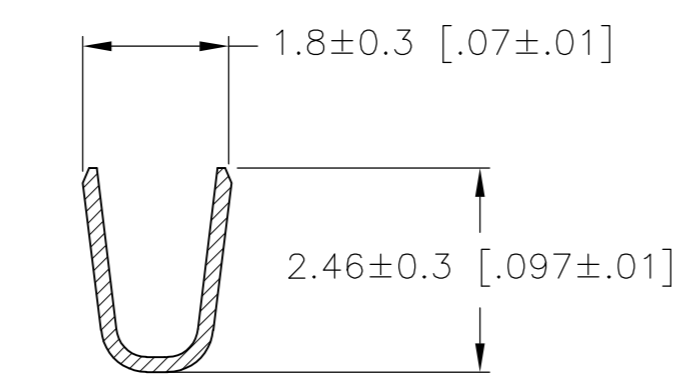
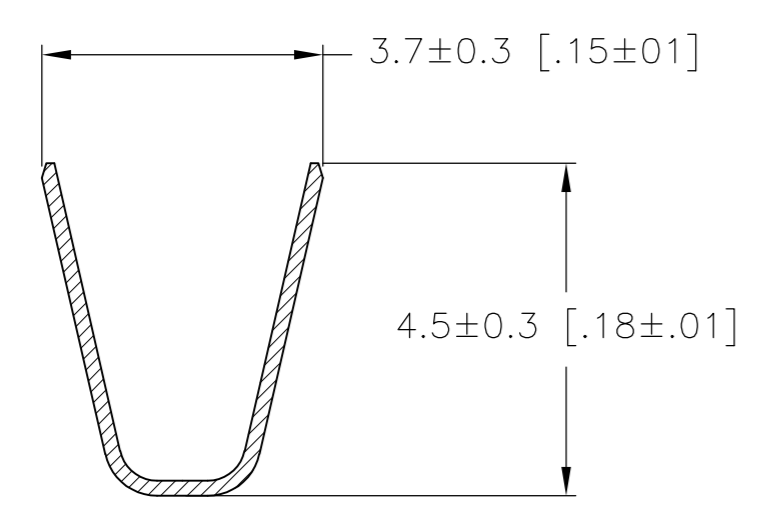
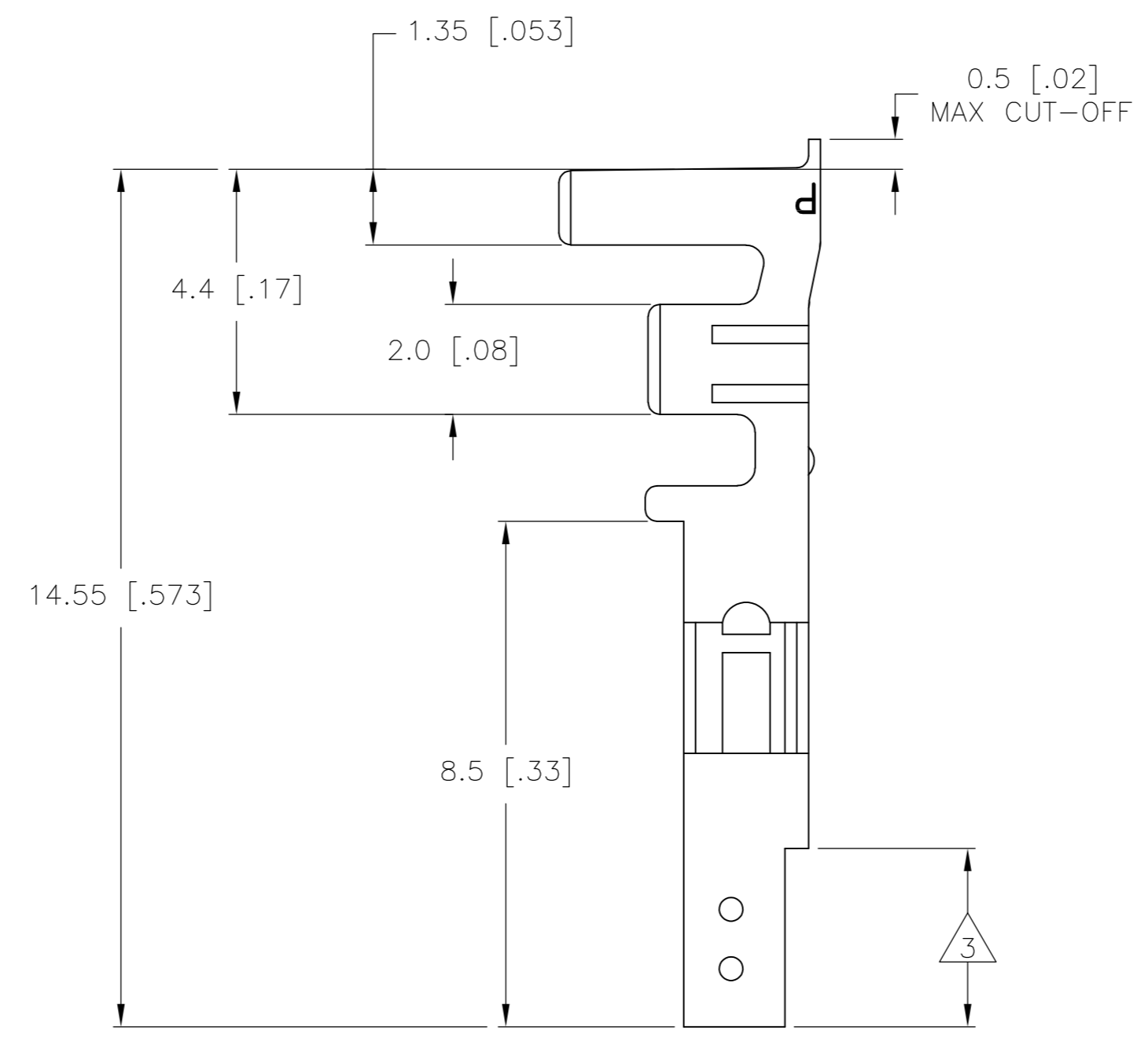
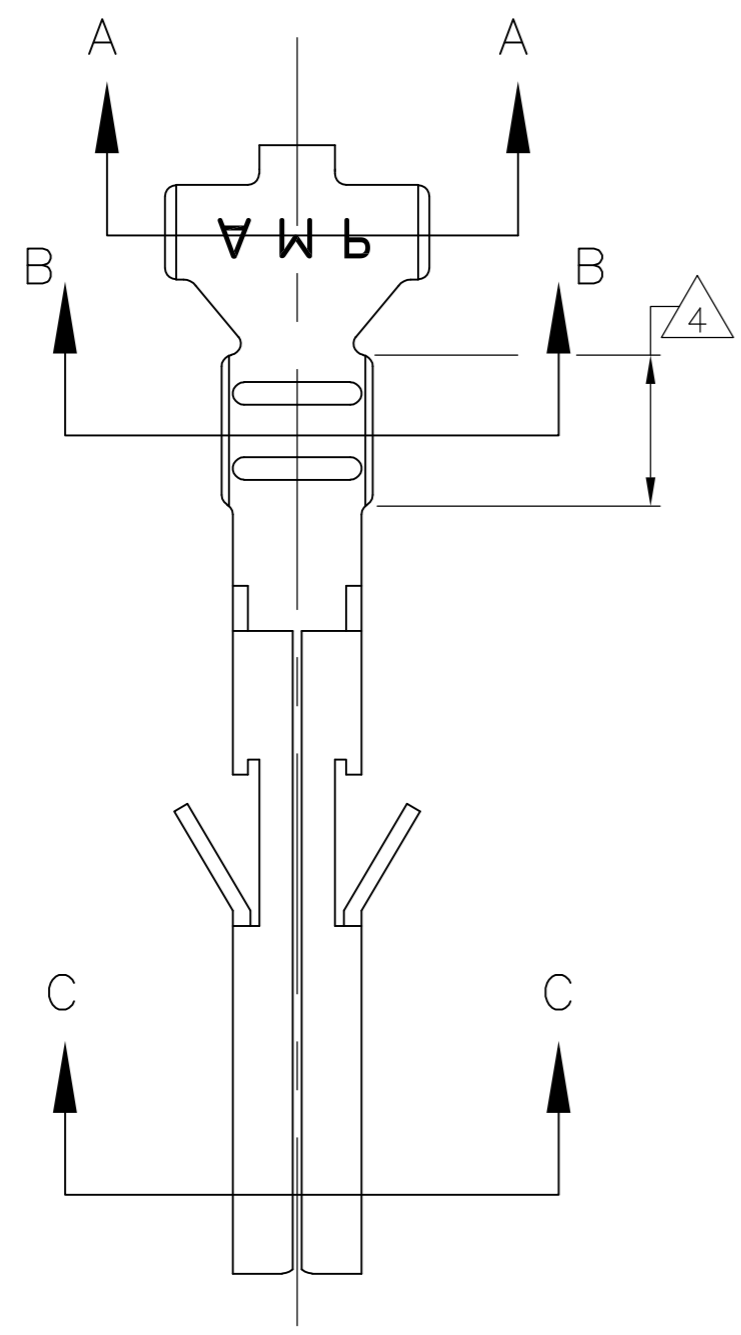

GOLD	3 4	PHOS. BRZ.	1586315-4
PRE-TIN		PHOS. BRZ.	1586315-3
GOLD	3 4	BRASS	1586315-2
PRE-TIN		BRASS	1586315-1
FINISH:		MATERIAL:	PART NO.

SECTION A-A

SECTION B-B

SECTION C-C

THIS DRAWING IS A CONTROLLED DOCUMENT.

DIMENSIONS: mm [INCHES]	TOLERANCES UNLESS OTHERWISE SPECIFIED: 0 PLC ± 1 PLC ± 0.3 [.01] 2 PLC ± 0.15 [.004] 3 PLC ± 0.050 [.0020] 4 PLC ± ANGLES ±	DWN S. HOOVER 14-OCT-2003 CHK D. COLEY 14-OCT-2003 APVD D. COLEY 14-OCT-2003 PRODUCT SPEC APPLICATION SPEC	NAME TE Connectivity
MATERIAL	FINISH	WEIGHT	SIZE A2 CAGE CODE 00779 C=1586315 RESTRICTED TO -
CUSTOMER DRAWING		SCALE 10:1	SHEET 1 OF 1 REV B1

1586315