

P	LTR	DESCRIPTION	DATE	DWN	APVD
	0	RELEASED(FC00-0120-04)	25JUN2004	JG	CS
	A	REVISED(ECR-17-016333)	09APR2019	HH	YJ

<0-1743161-2>

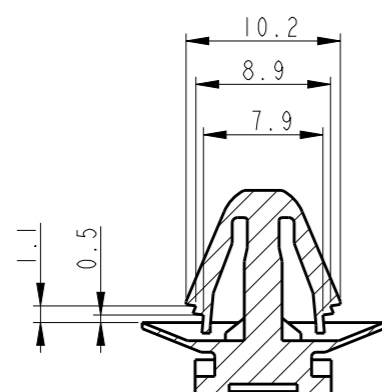

SECTION A-A

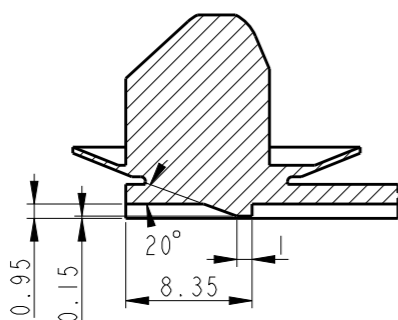
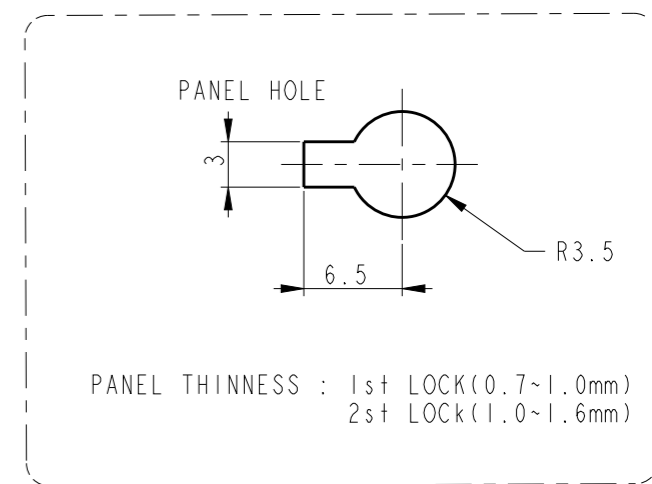
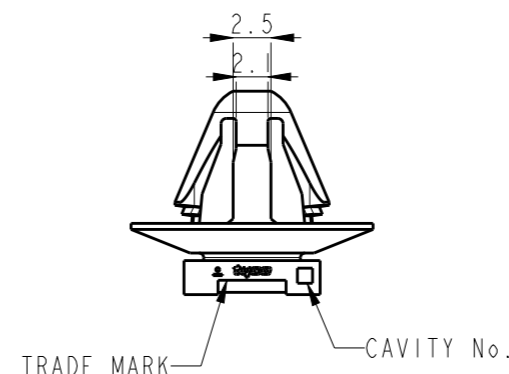
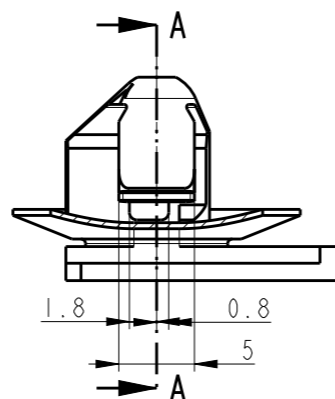
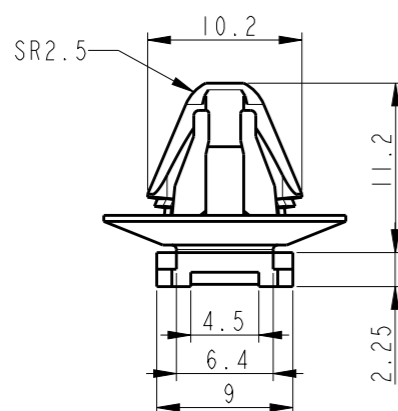
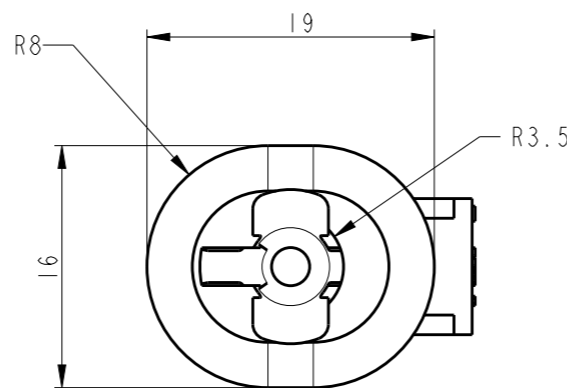

SECTION B-B

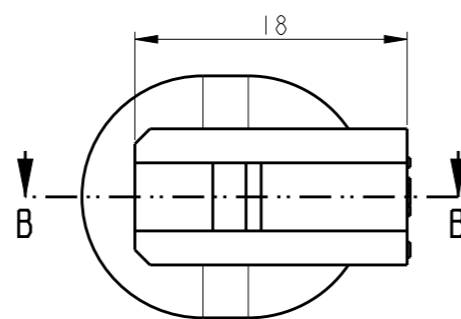

- NOTES
 1. GENERAL TOLERANCE : DIMENSION ± 0.3 ANGLE $\pm 1^\circ$
 2. APPLICABLE CAP ASS'Y CONN'R PART NO. : 0-1473407-1

NO.	COLOR	MATERIAL	DESCRIPTION	P/N
2	BLACK	PK	CLIP HSG	1-1743161-2
1	BLACK	NYLON66	CLIP HSG	0-1743161-2

THIS DRAWING IS A CONTROLLED DOCUMENT.

DIMENSIONS:
mm

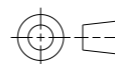

MATERIAL
SEE TABLE

TOLERANCES UNLESS OTHERWISE SPECIFIED:

0 PLC	\pm
1 PLC	\pm
2 PLC	\pm
3 PLC	\pm
4 PLC	\pm
ANGLES	\pm

FINISH

DWN	HH KIM
CHK	DG JEONG
APVD	YJ YOUN
PRODUCT SPEC	-
APPLICATION SPEC	-
WEIGHT	-

CUSTOMER DRAWING



NAME
CLIP HSG FOR 025 CONN'R 12PIN

SIZE	CAGE CODE	DRAWING NO	RESTRICTED TO
A3	00779	0-1743161	-

SCALE 5:1 SHEET 1 OF 2 REV A

P	LTR	DESCRIPTION	DATE	DWN	APVD
		SEE SHEET 1			

<1-1743161-2>

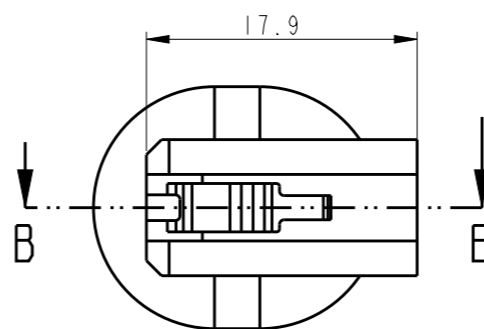
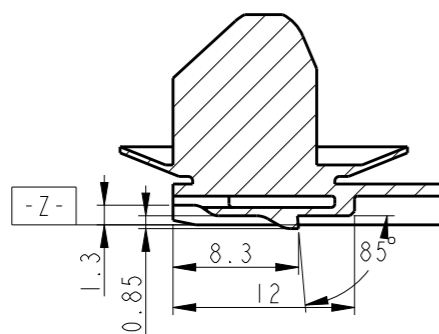
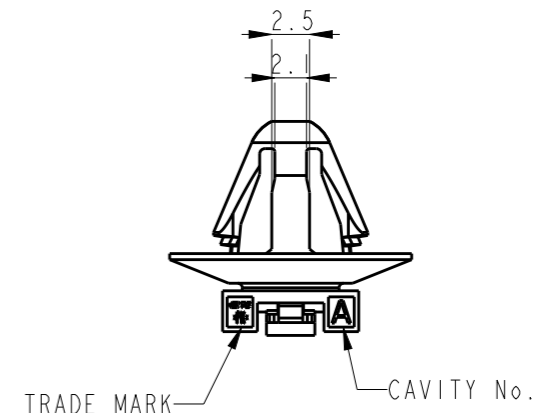
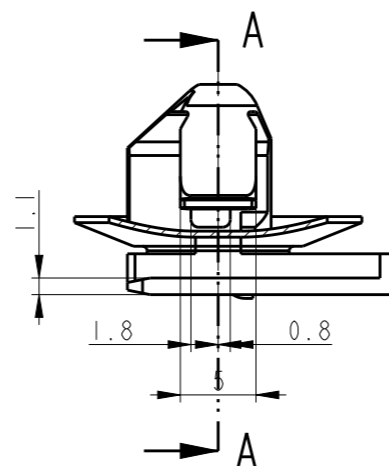
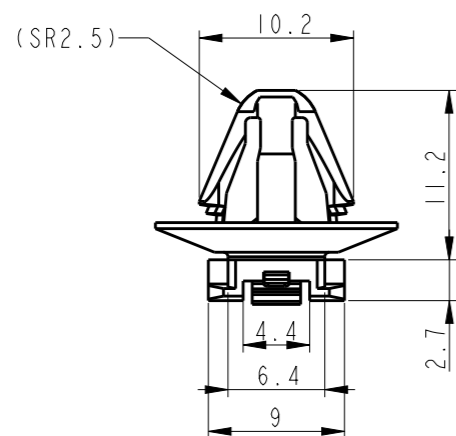
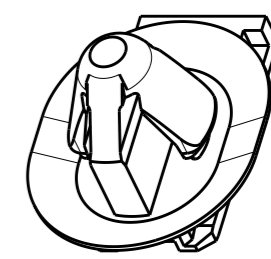
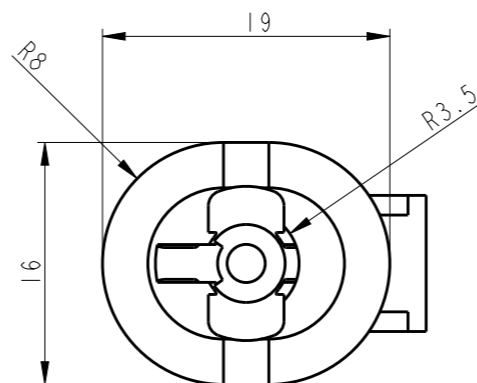
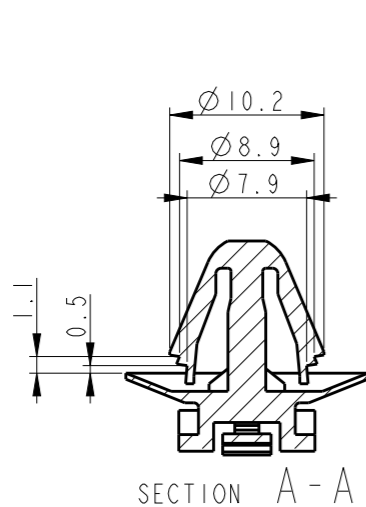

THIS DRAWING IS A CONTROLLED DOCUMENT.

DIMENSIONS:
mm

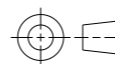

TOLERANCES UNLESS OTHERWISE SPECIFIED:

0 PLC	±:
1 PLC	±0.5
2 PLC	±0.13
3 PLC	±0.013
4 PLC	±0.0001
ANGLES	±:

MATERIAL
TBD
material_2

FINISH
-
finish_spec_2

DWN	-
CHK	-
APVD	-
PRODUCT SPEC	-
APPLICATION SPEC	-
WEIGHT	-
CUSTOMER DRAWING	



NAME
CLIP HSG FOR 025 CONN'R 12PIN

SIZE CAGE CODE DRAWING NO RESTRICTED TO

A3 00779 C-1743161

SCALE 5:1 SHEET 2 OF 2 REV A