

- PART NUMBER 1488991-5 SHOWN ON DRAWING.
- TPA AND CPA (WHEN APPLICABLE) ARE SHIPPED IN THEIR PRE-LATCHED POSITIONS. SEE INSTRUCTION SHEET 408-8928 FOR DIRECTIONS ON MOVING THE CPA AND TPA TO THE PRE-LATCHED POSITION, IF NECESSARY.
- TERMINALS SOLD SEPARATELY. FOR USE WITH TE CONNECTIVITY MCON 1.2mm CLEAN BODY CONTACT WITH WIRE SEAL. SEE MCON 1.2-CB (CLEAN BODY) TABLE FOR APPLICABLE PART NUMBERS.
- APPLICABLE HEADER INTERFACE DRAWING 1488738 IS AVAILABLE UPON REQUEST. A COPY OF THIS DRAWING CAN BE OBTAINED FROM THE TE CONNECTIVITY PRODUCT MANAGER, VIA YOUR TE CONNECTIVITY SALES REPRESENTATIVE OR CUSTOMER SERVICE.
- MINIMUM FEED THROUGH CONDITION WITH 0.5mm CLEARANCE ALL AROUND.
- A "X" IN THIS TABLE INDICATES THAT THE TERMINAL CAVITY IS BLOCKED AND WILL NOT ALLOW INSERTION OF THE MATING TERMINAL. A "O" IN THIS TABLE INDICATES THAT THE TERMINAL CAVITY IS OPEN AND WILL ALLOW INSERTION OF THE MATING TERMINAL.
- TRACEABILITY PRINTED IN THIS LOCATION AT ASSEMBLY.
- CONNECTOR SYSTEM MEETS THE REQUIREMENTS OF USCAR-2, REVISION 3, EXCEPT WHERE NOTED:  
 TPA ENGAGE AND DISENGAGE FORCES ARE 10N MIN - 30N MAX.  
 PRIMARY TERMINAL-CONNECTOR FORCE IS 30N MIN.  
 SECONDARY TERMINAL-CONNECTOR FORCE IS 75N MIN.  
 CPA ENGAGE AND DISENGAGE FORCES (WITH MATING CONNECTOR) ARE 30N MAX.  
 CPA REMOVAL FORCE FROM CONNECTOR IS 15N MIN.
- FOR OPTIONAL TERMINAL CAVITY BLOCKING, USE TE CONNECTIVITY BLIND PLUG PART NUMBER: 967056-1.
- TERMINAL 1670146-X REPLACES 1418847-X
- REFERENCE ISOMETRIC VIEWS ON SHEET 2.

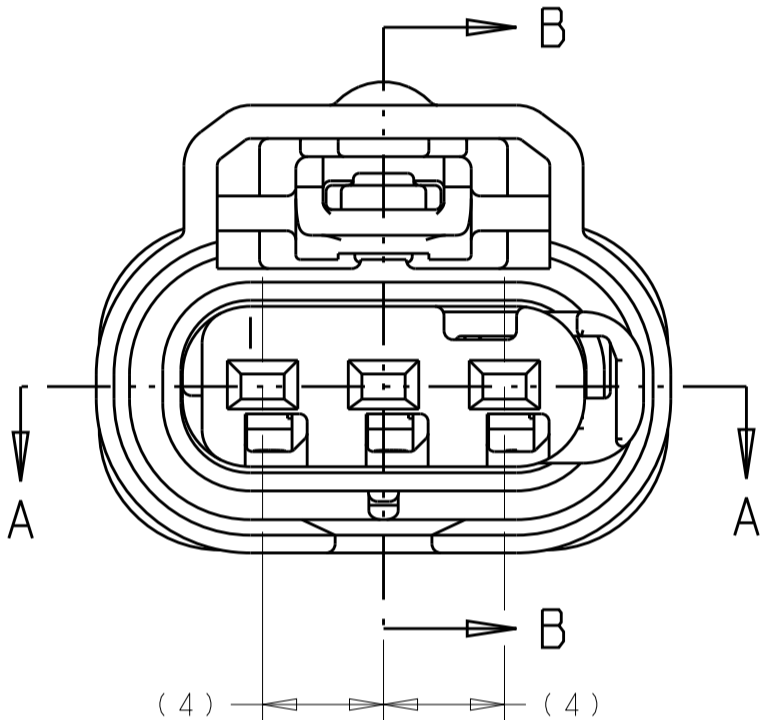

REVISIONS				
P. LTM	DESCRIPTION	DATE	OWN	APP'D
F8	REVISED PER ECO-13-001652	12FEB2013	DLD	SLM
F9	REVISED PER ECO-15-002909	25FEB2015	DLD	SLM
F10	REVISED PER ECO-15-011380	05AUG2015	DLD	SLM

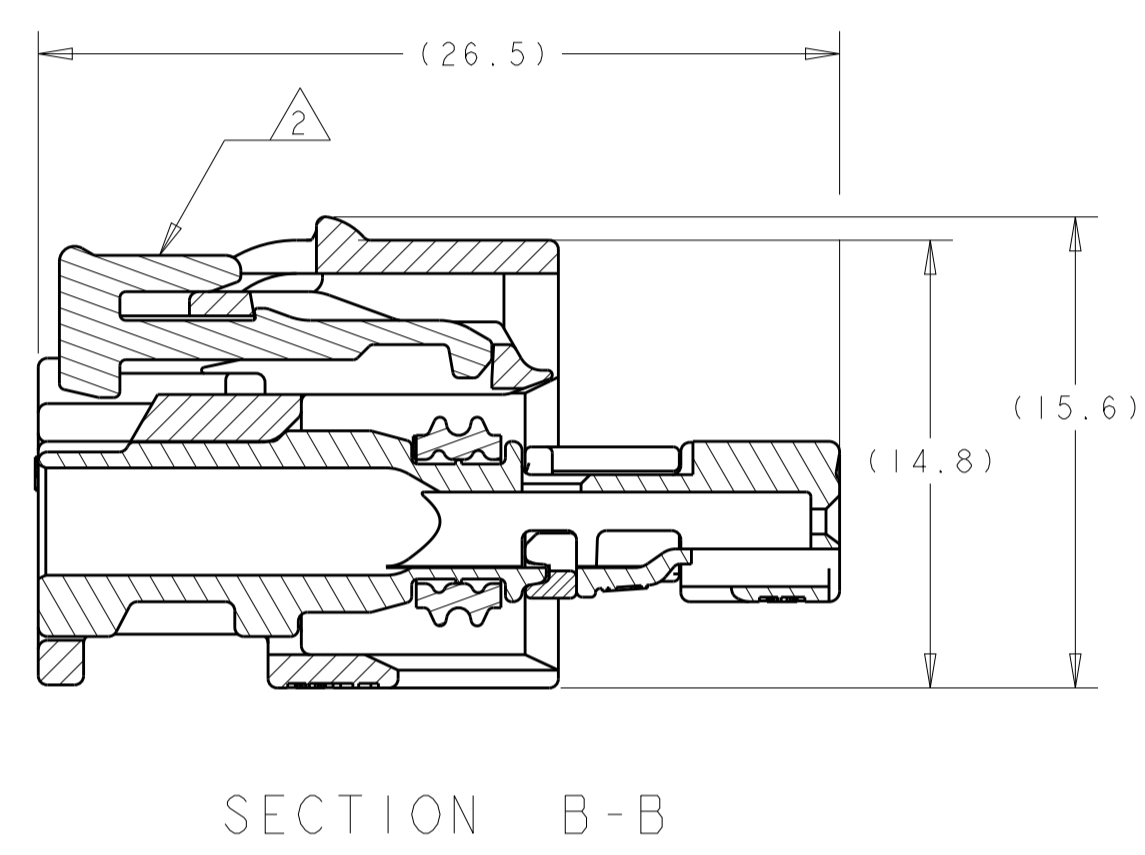
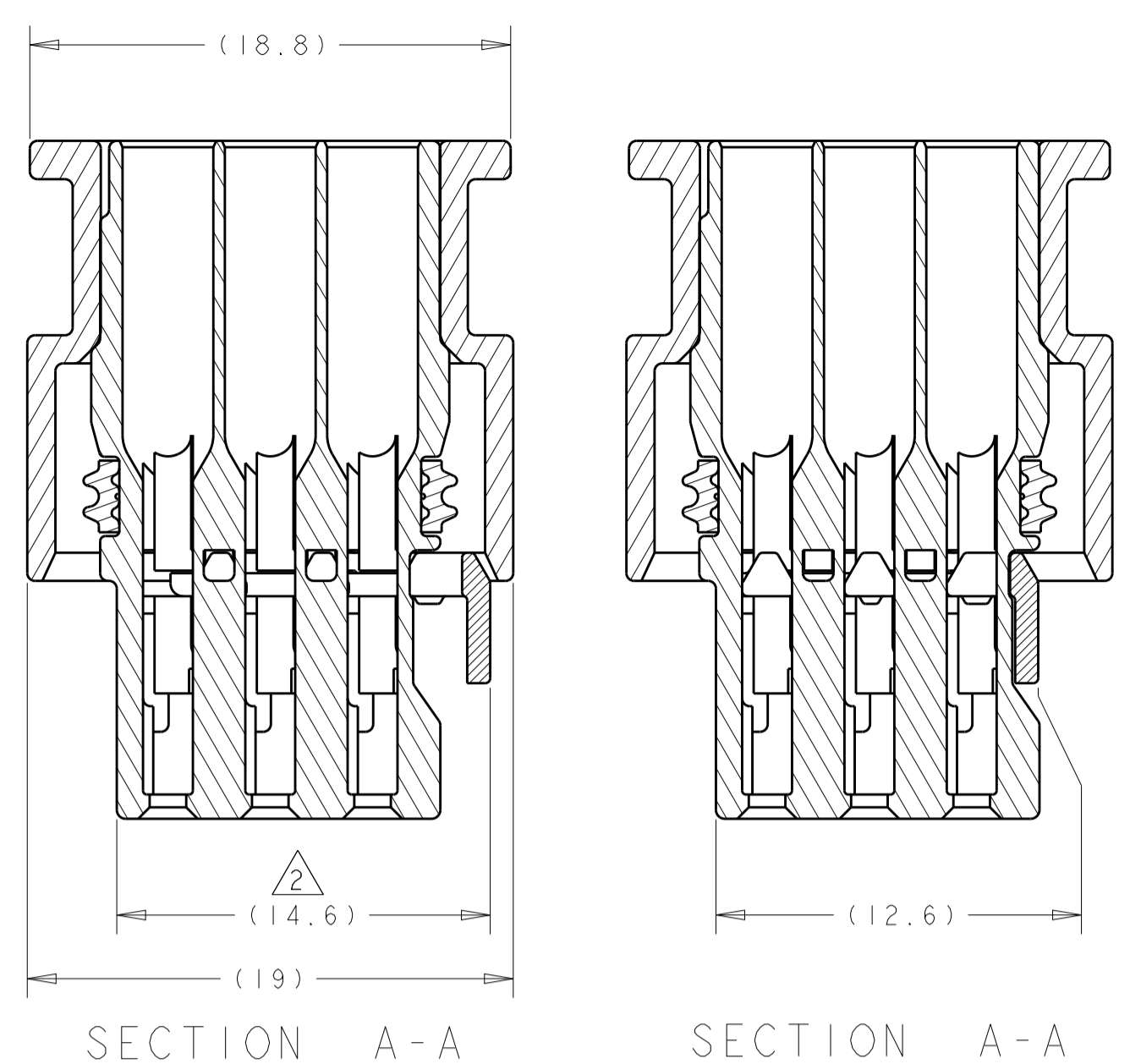
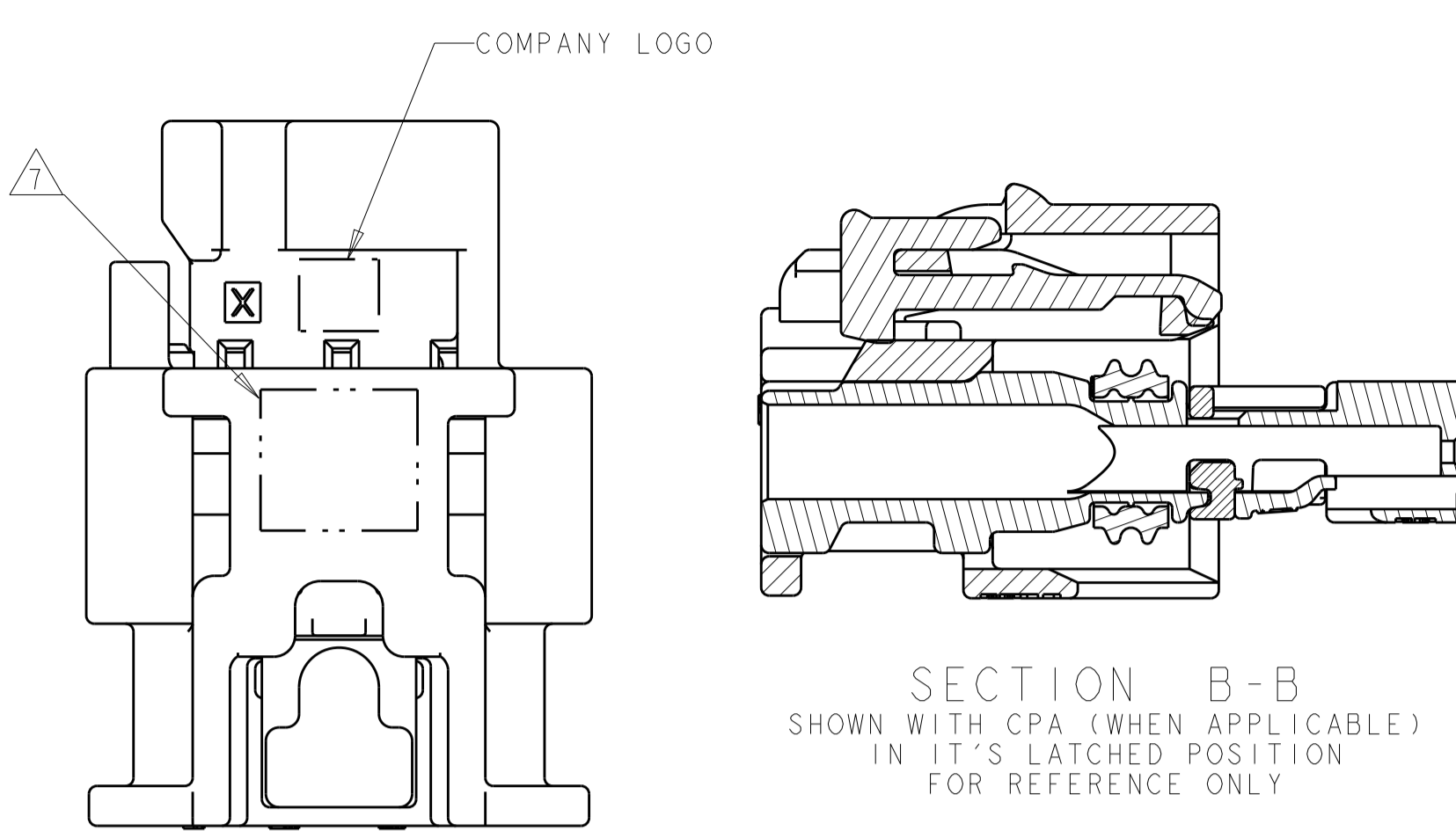
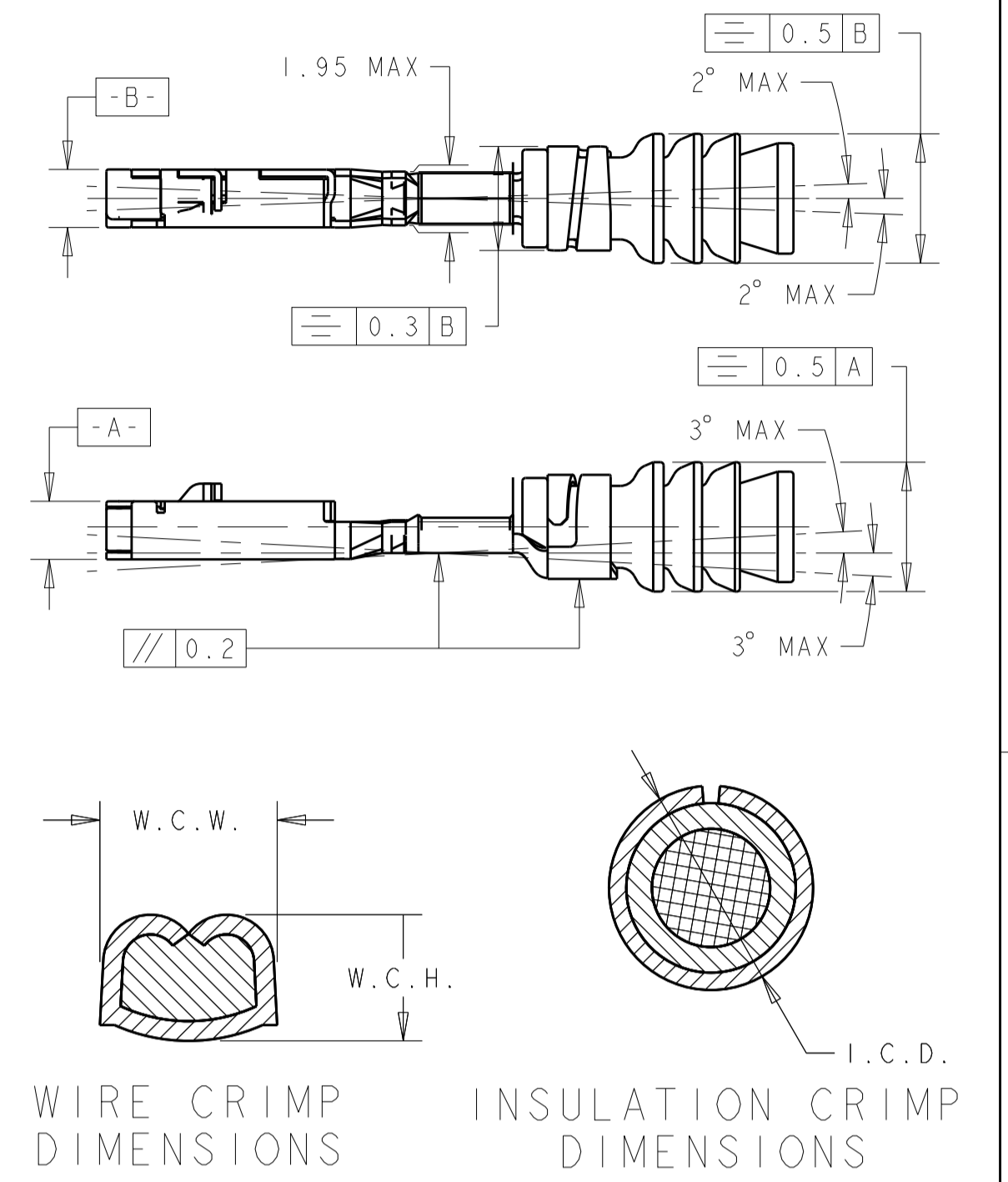

KEYING CONFIGURATIONS	TERMINAL CAVITY CONFIGURATIONS
KEYING OPTION A	ALL TERMINAL CAVITIES OPEN
KEYING OPTION B	TERMINAL CAVITY #3 CLOSED
KEYING OPTION C	TERMINAL CAVITY #2 CLOSED
KEYING OPTION D	TERMINAL CAVITY #1 CLOSED

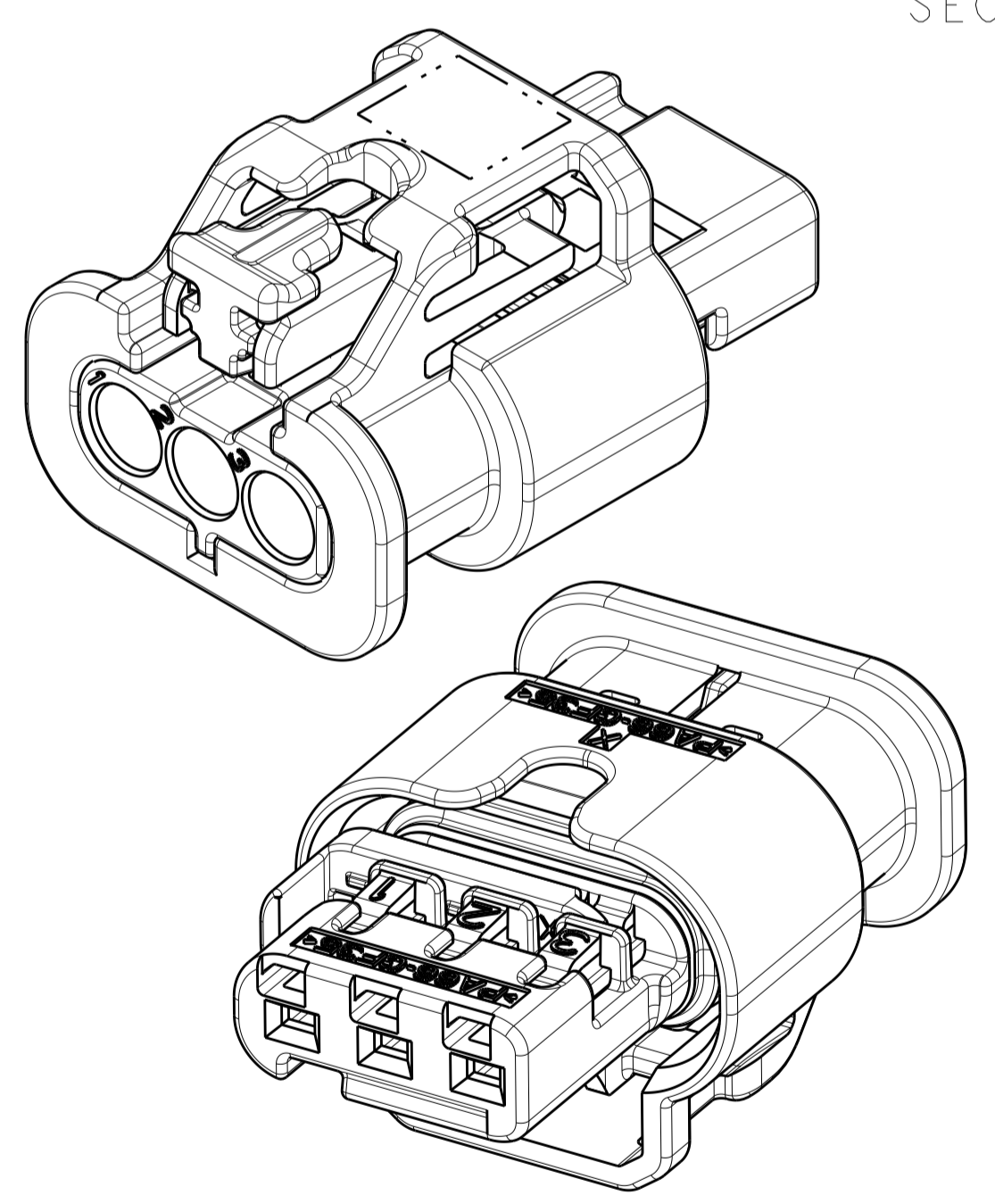

MCON 1.2-CB (CLEAN BODY)								
PART NUMBER	PLATING	WIRE STRIP LENGTH	AWG	INSL. RANGE	W.C.H.	W.C.W.	I.C.D.	WIRE SEAL PART NUMBER
1418844-3	SILVER	3.3 ± 0.3	22	1.2 TO 1.4	0.86 ± 0.03	1.27 ± 0.05	3.15 ± 0.05	967067-2
1418844-2	GOLD							
1418844-1	TIN							
1670146-3	SILVER	3.6 ± 0.3	20	1.4 TO 1.9	0.84 ± 0.03	1.57 ± 0.05	3.25 ± 0.05	967067-1
1670146-2	GOLD							
1670146-1	TIN							
1418850-3	SILVER			1.8 TO 2.4	1.11 ± 0.05	1.78 ± 0.05	3.35 ± 0.05	964972-1
1418850-2	GOLD	3.6 ± 0.3						
1418850-1	TIN							

RELEASED	2138907-1	GRAY	D	O	O	O	4-1488991-4
RELEASED	2138907-1	BLUE	C	O	O	O	4-1488991-3
RELEASED	2138907-1	NATURAL	B	O	O	O	4-1488991-2
RELEASED	2138907-1	BLACK	A	O	O	O	4-1488991-1
NOT RELEASED	1488787-1	GRAY	D				3-1488991-2
	1488787-1	BLUE	C	X	O	O	3-1488991-1
	1488787-1	NATURAL	B				3-1488991-0
	1488787-1	BLACK	A				2-1488991-9
RELEASED	N/A	GRAY	D				2-1488991-8
NOT RELEASED	N/A	BLUE	C	X	O	O	2-1488991-7
	N/A	NATURAL	B				2-1488991-6
RELEASED	N/A	BLACK	A				2-1488991-5
NOT RELEASED	1488787-1	GRAY	D				2-1488991-4
	1488787-1	BLUE	C	O	X	O	2-1488991-3
	1488787-1	NATURAL	B				2-1488991-2
	1488787-1	BLACK	A				2-1488991-1
NOT RELEASED	N/A	GRAY	D				2-1488991-0
	N/A	BLUE	C		X	O	1-1488991-9
	N/A	NATURAL	B	O	X	O	1-1488991-8
	N/A	BLACK	A				1-1488991-7
NOT RELEASED	1488787-1	GRAY	D				1-1488991-6
	1488787-1	BLUE	C	O	O	X	1-1488991-5
	1488787-1	NATURAL	B				1-1488991-4
	1488787-1	BLACK	A				1-1488991-3
NOT RELEASED	N/A	GRAY	D				1-1488991-2
	N/A	BLUE	C	O	O	X	1-1488991-1
	N/A	NATURAL	B				1-1488991-0
	N/A	BLACK	A				1488991-9
RELEASED	1488787-1	GRAY	D				1488991-8
RELEASED	1488787-1	BLUE	C				1488991-7
RELEASED	1488787-1	NATURAL	B	O	O	O	1488991-6
RELEASED	1488787-1	BLACK	A				1488991-5
RELEASED	N/A	GRAY	D				1488991-4
RELEASED	N/A	BLUE	C	O	O	O	1488991-3
RELEASED	N/A	NATURAL	B				1488991-2
RELEASED	N/A	BLACK	A				1488991-1

THIS DRAWING IS A CONTROLLED DOCUMENT. DIMENSIONS: mm. TOLERANCES UNLESS OTHERWISE SPECIFIED: 0 PLC ±0.3, 1 PLC ±0.3, 2 PLC ±0.3, 3 PLC ±0.3, 4 PLC ±0.3, ANGLES ±0.1°. MATERIAL: SEE TABLE. FINISH: SEE TABLE.

OWN: M. FORLSKA 08MAR2004. CHK: G. MARTIN 08MAR2004. AP'D: G. MARTIN 08MAR2004. PRODUCT SPEC: IS 408-8928. WEIGHT: 3.0 GRAMS. CUSTOMER DRAWING: A100779C=1488991. SCALE: 4:1. SHEET 1 OF 2. REV: F10.

**STE** TE Connectivity  
CONNECTOR ASSEMBLY, FEMALE, 3 POSITION, SEALED, 1.2mm (STANDARD LATCH VERSION)

REVISIONS				
P.	LTN	DESCRIPTION	DATE	APVD
-	-	SEE SHEET 1	-	-

ISOMETRIC VIEWS

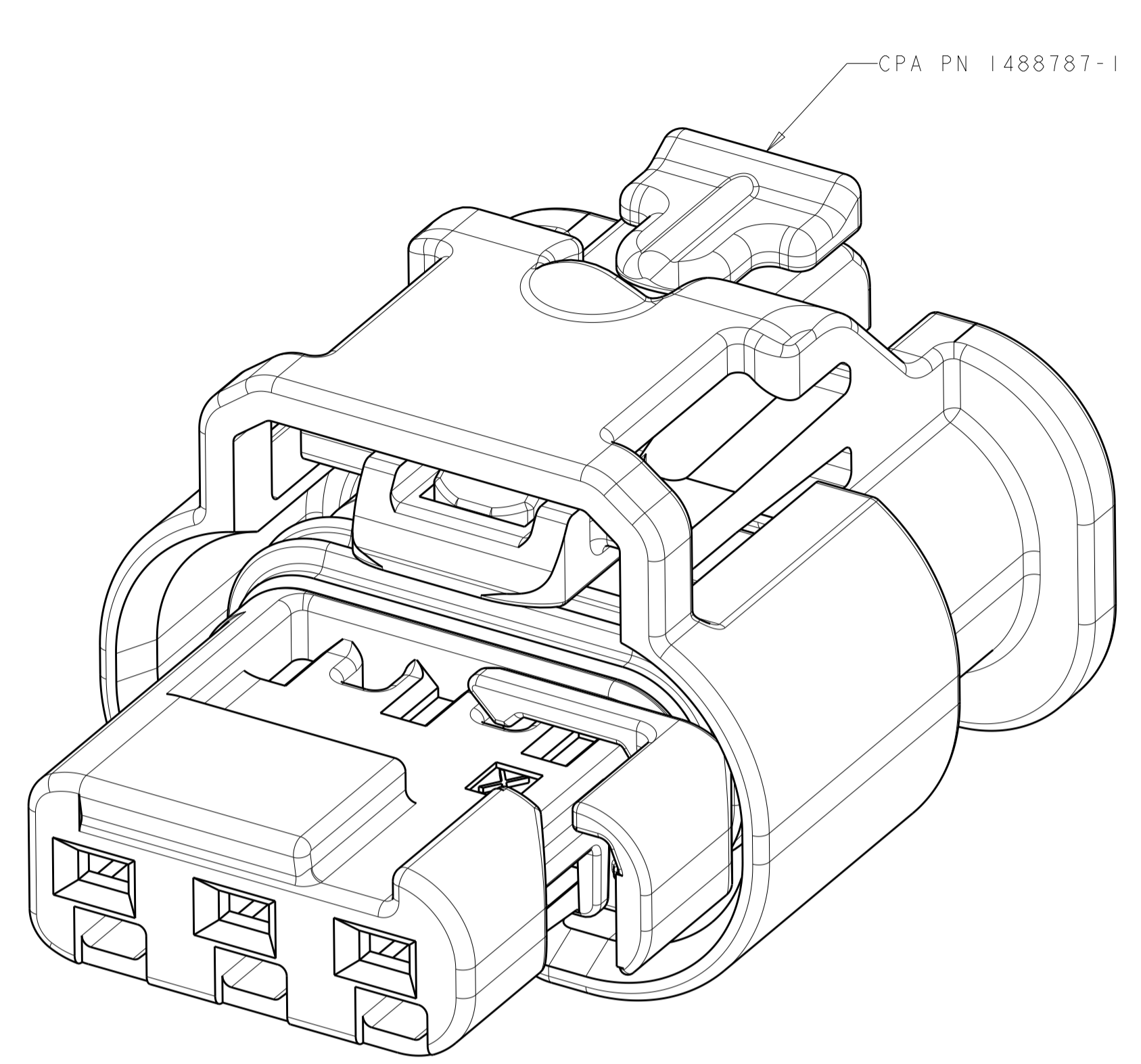

PN 1488991-5 SHOWN  
SCALE 8:1

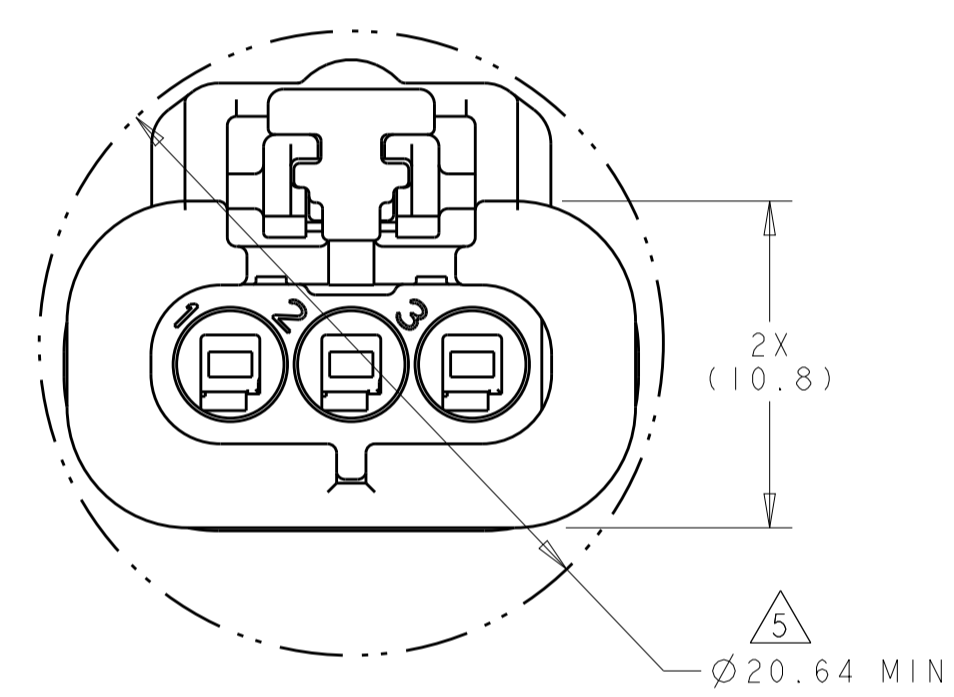

FEED THROUGH CONDITION

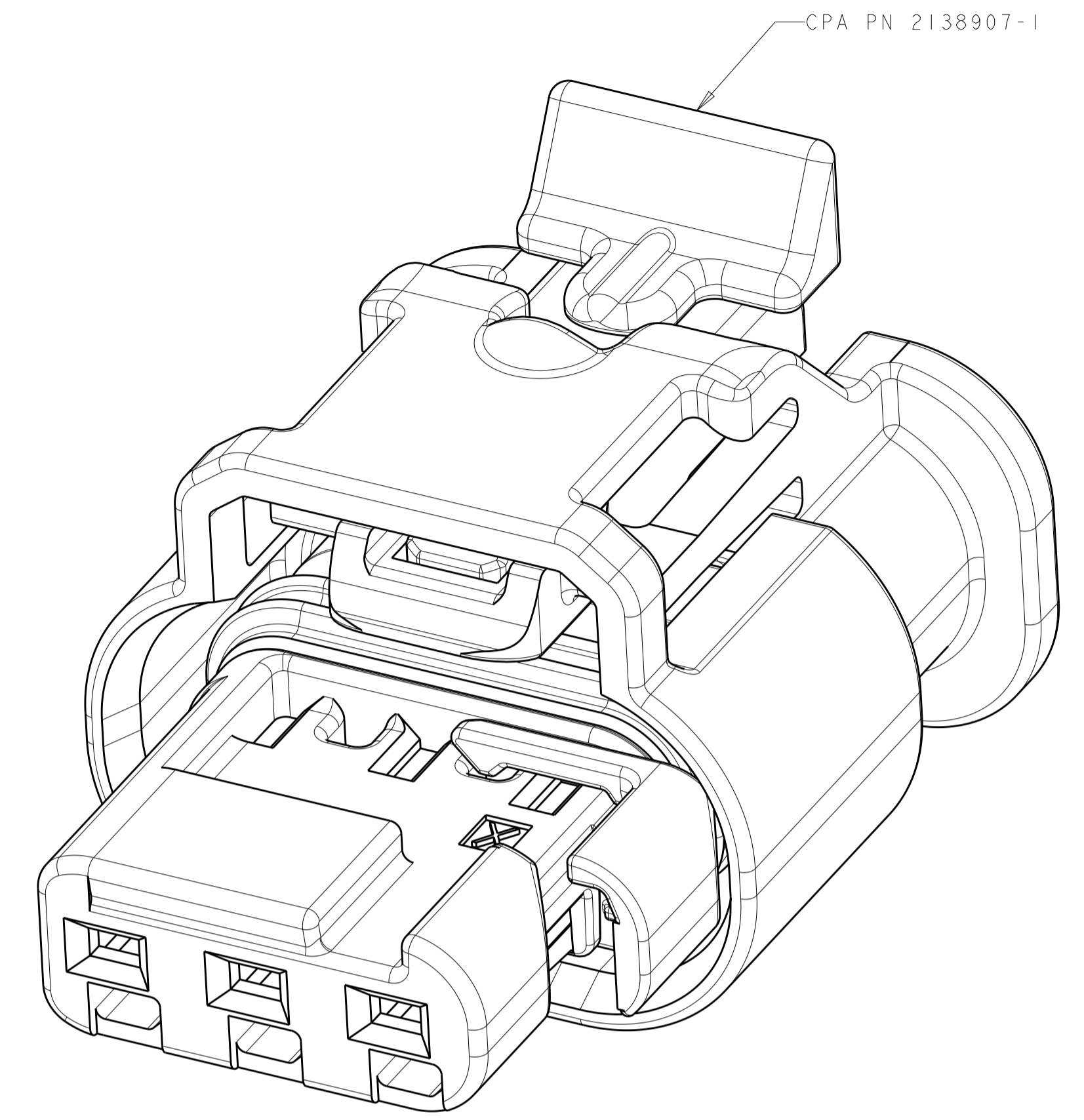

PN 4-1488991-1 SHOWN  
SCALE 8:1

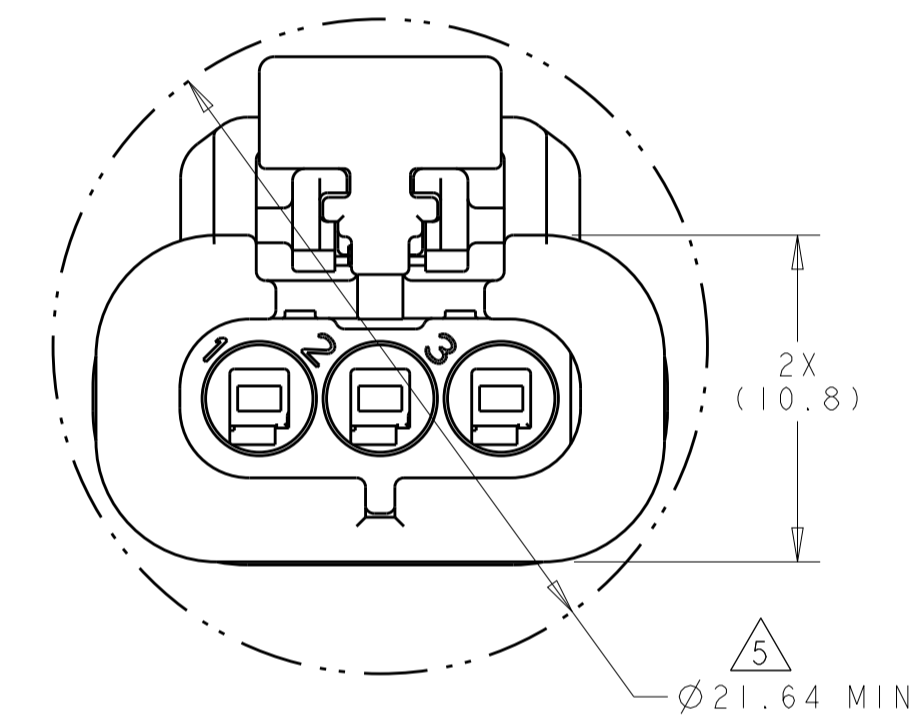

FEED THROUGH CONDITION

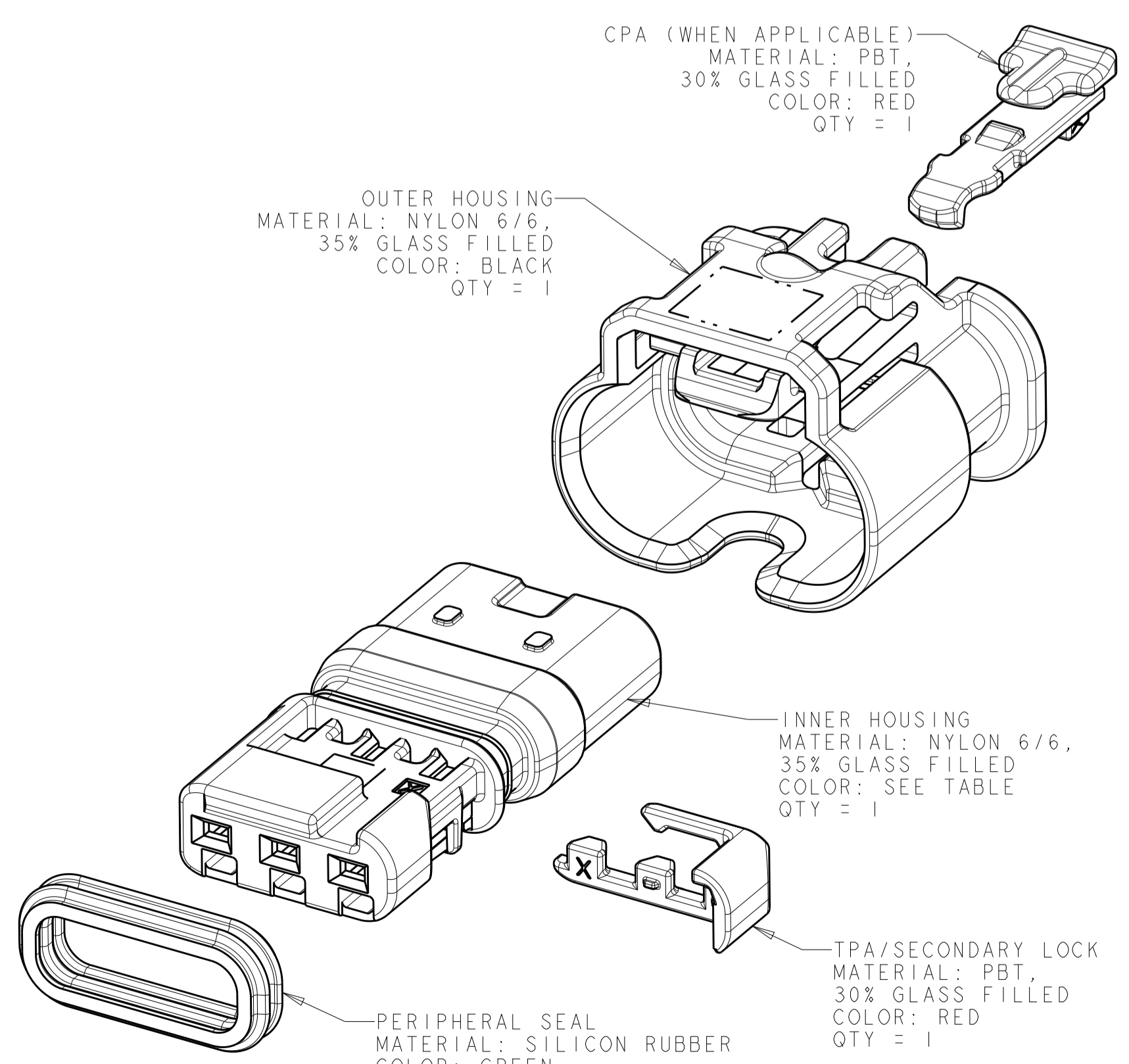

- CPA (WHEN APPLICABLE)  
MATERIAL: PBT,  
30% GLASS FILLED  
COLOR: RED  
QTY = 1
- OUTER HOUSING  
MATERIAL: NYLON 6/6,  
35% GLASS FILLED  
COLOR: BLACK  
QTY = 1
- INNER HOUSING  
MATERIAL: NYLON 6/6,  
35% GLASS FILLED  
COLOR: SEE TABLE  
QTY = 1
- TPA/SECONDARY LOCK  
MATERIAL: PBT,  
30% GLASS FILLED  
COLOR: RED  
QTY = 1
- PERIPHERAL SEAL  
MATERIAL: SILICON RUBBER  
COLOR: GREEN  
QTY = 1

EXPLODED ISOMETRIC VIEW

THIS DRAWING IS A CONTROLLED DOCUMENT.		DWN M. FORISKA 08MAR2004 CHK G. MARTIN 08MAR2004 APVD G. MARTIN 08MAR2004	TE Connectivity
DIMENSIONS: mm TOLERANCES UNLESS OTHERWISE SPECIFIED: 0 PLC ± 1 PLC ±0.3 2 PLC ±0.10 3 PLC ± 4 PLC ± ANGLES ±1°		NAME CONNECTOR ASSEMBLY, FEMALE, 3 POSITION, SEALED, 1.2mm (STANDARD LATCH VERSION) APPLICATION SPEC IS 408-8928 WEIGHT 3.0 GRAMS CUSTOMER DRAWING	
MATERIAL - FINISH - SEE TABLE -		SIZE CAGE CODE DRAWING NO. A100779C-1488991 RESTRICTED TO	SCALE 4:1 SHEET 2 OF 2 REV F10