

PRODUCT NO.	RoHS compliant
DSIC06LHGET	

REV.	ECN NO.	DR	DATE

NOTES :

- Specification:
 - Operating force: 1000gf Max
 - Operating Temperature: -40° to +85°
 - Storage Temperature: -40° to +85°
 - Mechanical Life: 3000cycles minimum
 - Electrical Life: 2000cycles 25mA 24VDC

- PLATING:
 - GOLD FLASH 1u"~2u" SOLDER TAIL,
 - 1u"~3u" GOLD PLATING ON THE CONTACT AREA,
 - WITH 50u" NICKEL UNDERPLATING OVERALL.

3. PART NUMBER DESCRIPTION

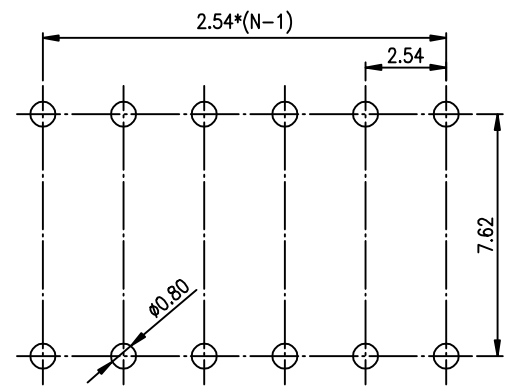
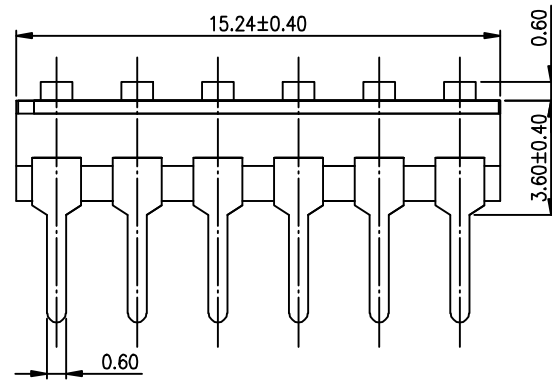
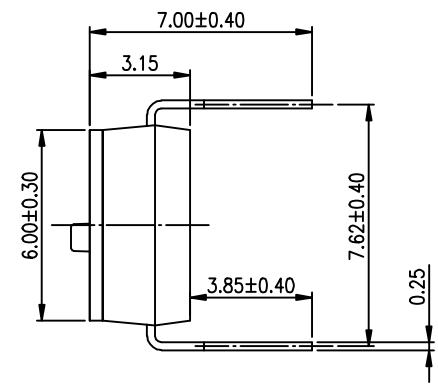
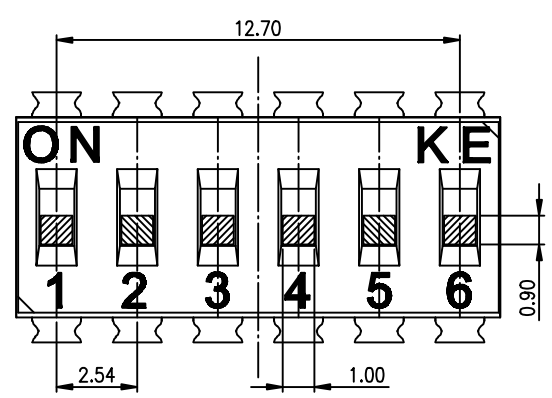
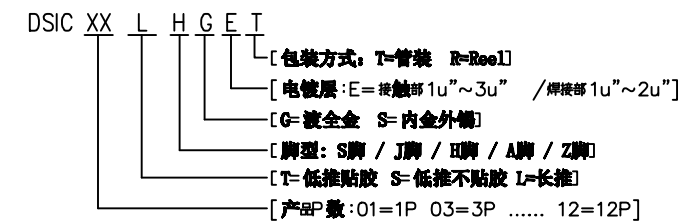

RECOMMENDED P.C.B. LAYOUT (TOP VIEW)

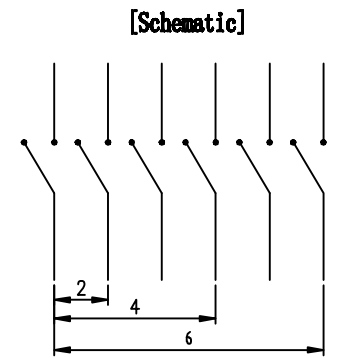

[Schematic]

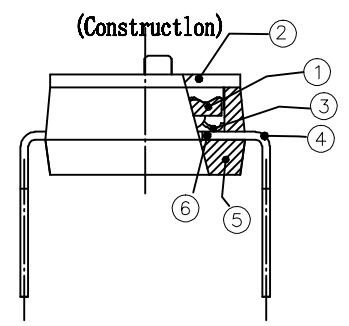
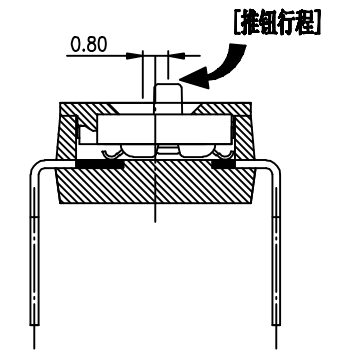

(Construction)

Number	Part Name	Material	Finished	TOLERANCE UNLESS OTHERWISE SPECIFIED		INSPECTION COPY	PROJECTION	TITLE
				LINER	ANGLES			
①	Actuator	UL94 V0	White	.0 ± 0.25	0. ± 2'	2012/04/12	[Symbol]	BY DSIC SERIES PITCH 2.54mm
②	Cover	UL94 V0	Black	.00 ± 0.15	.0 ± 1'			
③	Movable	Copper Alloy	1u"~3u"Gold	.000± 0.10	.00± 0.5'			
④	Terminal	Brass	1u"~2u"Gold	DESIGN	kathy			
⑤	Base	UL94 V0	Black	DRAWING				
⑥	Terminal Contact	Brass	1u"~3u"Gold	CHECK				
				APPRO.		DRAWING SHEET REV.		

Kingtek 东莞市广普实业有限公司
DongGuan Kingtek Industrial Co., Ltd.

PRODUCT FAMILY DSIC SERIES				
PRAT NO. DSIC06LHGET				
FILE NO. DSIC06LHGET-A				
SIZE	UNIT	SCALE	SHEET	REV.
A4	mm	2 : 1	1 OF 1	A