



深圳市胜丰宏电子有限公司

APPROVAL SHEET

Customer: patwary

Customer P/N: SF 4010SM12 FG 三线

Description: DC FAN

Model NO.: SF 4010SM12

Version.: A Issue NO:2021SF0522

Issue date: 2021-05-22 Quantity: 1200PCS

*Please sign back this specification for our record upon your approval.

Thanks!

Company Stamp	CUSTOMER APPROVAL Stamp
制作: 龙必兴	承认:
复核: 胡超	核准:
核准: 李厚群	日期:

工厂地址: 东莞市凤岗镇竹塘下围村大塘北路 6 号合泰工业园 A 栋 3 楼

免费咨询和订购热线: 400-9920-988 官方网站 <http://www.fancool.net/>

E-Mail: fancool8@163.com

1.0: 一般规格 (General Specification)

项目 (Item)		规格/条件 (Specification/Condition)	
1	型号(Model No.)	SF 4010SM12	
2	外型尺寸(Outline Dimension)	40*40*11	
3	工作电压 (Operating Voltage)	DC 7.0-13.8V	
4	额定电压 (Rated voltage)	DC 12.0 V	
5	起动电压 Starting Voltage	DC ≤7.0V on/off	
6	额定电流 (Rated current)	0.06A±10%	a. 额定电压 (Rated voltage) b. 25°C 65% RH c. After testing for 5 minutes
7	消耗功率 (Power consumption)	0.72W±10%	
8	转速 (Speed)	6500±10%RPM	
9	最大风量: (Max Airflow)	6.20CFM	a. 额定电压 (Rated voltage) b. AMCA 标准 (Standard) c. 额定电流 (Rated current)
	最大静压: (Air Static Pressure)	3.50mmH2O	
10	最大噪音 (Max Noise)	Max:33.40Db-A	a. 额定电压 (Rated Voltage) b. 18dB无响室 (18dB Non-Echo Chamber) c. 标准 (Standard):CNS 8753 / ISO 3744 d. Test Condition :ISO 7779 e. 距离 (Distance): 1.0 M
11	扇叶数 (No.of.Blade)	9 叶	
12	极数 (No.of.Pole)	4 极	
13	运转方向 (Rotating Direction)	逆时针/运转方向是从扇叶面看	
14	锁住保护 Lock Protection	<input type="checkbox"/> 无 NO	
15	极性保护 Polarity Protection	<input type="checkbox"/> 无 NO	
16	FG 功能 (FG function)	转速反馈 Tachometer Output	

2.0:主要材料/零件规格 (Main Materials/parts Specification)

材料/零件 (Materials/parts)		规格 (Specification)		
1	塑料材料/扇叶 外框 (Plastic Material/Blade,Housing)	PBT 黑色方框 7 叶		
2	轴承 (Bearing Type)	含油轴承 (Sleeve bearing)		
3	引线 (Lead Wire)	UL1007#24#190mm 黑红黄分线 2510 三 PIN		
4	端子 (Connector)	黑 (RND)	红 (VCC)	黄 (FG)
5	环保要求 (Environmental Requirement)	<input type="checkbox"/> ROHS	<input type="checkbox"/> 无卤	<input type="checkbox"/> fireproof

3.0 電性規格 (Electrical Specifically) 有 YES 输出 FG 方波 (齿型) 反馈信号。

1	絕緣阻抗 Insulation Resistance	10MΩ/裸線与外框間測量，500VDC/min 10MΩ/between unshackled wire and frame at 500VDC/min
2	絕緣耐压 Dielectric Strength	5Ma Max./導線与外框間測量，500VAC/min 5Ma Max./Measured between lead wire(+)and frame at 500VAC/min
3	防水等级 Waterproof level	IP X0

4.0 环境测试 (Environmental Specification)

1	运转温/湿度范围 Operating Temp .Range	温度/Temperature:-10°C - +70°C 湿度/Humidity:5% - 95%RH
2	保存温/湿度范围 Storage Temperature	温度/Temperature:-40°C - +75°C 湿度/Humidity:5% - 95%RH
3	耐湿性 Humidity	电气规格依据 MIL-STD 202F Method 103B 湿度: 95%RH 温度: 40±2°C
4	热冲击 Thermal Shock	电气规格依据 MIL-STD 202F Method 107D Per MIL-STD 202F Method 107D,Condition D
5	绝缘阶段 Insulation Shock	UL: A 种 UL: Class A
6	包装耐振动试验 Packing Vibration Test	包装后, XYZ 三方向施 1.1G load vibration test for 30min .No serious damage

7	包装耐冲击试验 Packing Shock Proof Test	捆包后, 高 60 公分, 1 棱角 3 边 6 面自然落下, 无严重损坏。 1corner, 3edges, 6faces natural drop from 60cm high packing No serious damage
---	-------------------------------------	---

5.0 在无响室额定电压下之噪音测试

(NOISE IS MEASURED AT RATED VOLTAGE IN ANECHOIC)

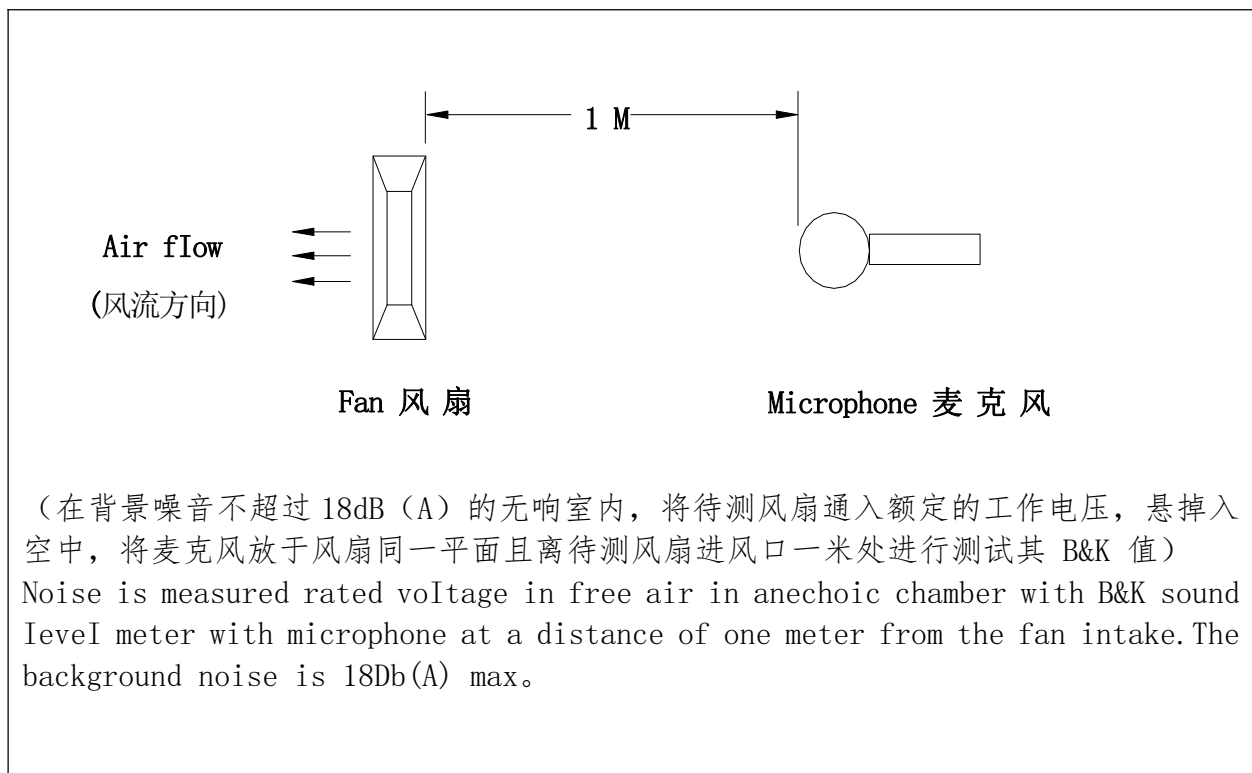

6.0 平均寿命说明 (Life Expectancy Explanation)

在指定恒温下持续工作后, 经检验, 90%能正常运转即可估算其平均使用寿命 (The continuous duty life at given temperature after which, 90% of testing units shall still be running)。

Sleeve System	Test Temperature	Test time (H)
Sleeve Bearing	25°C	25000

7.0 外观图:

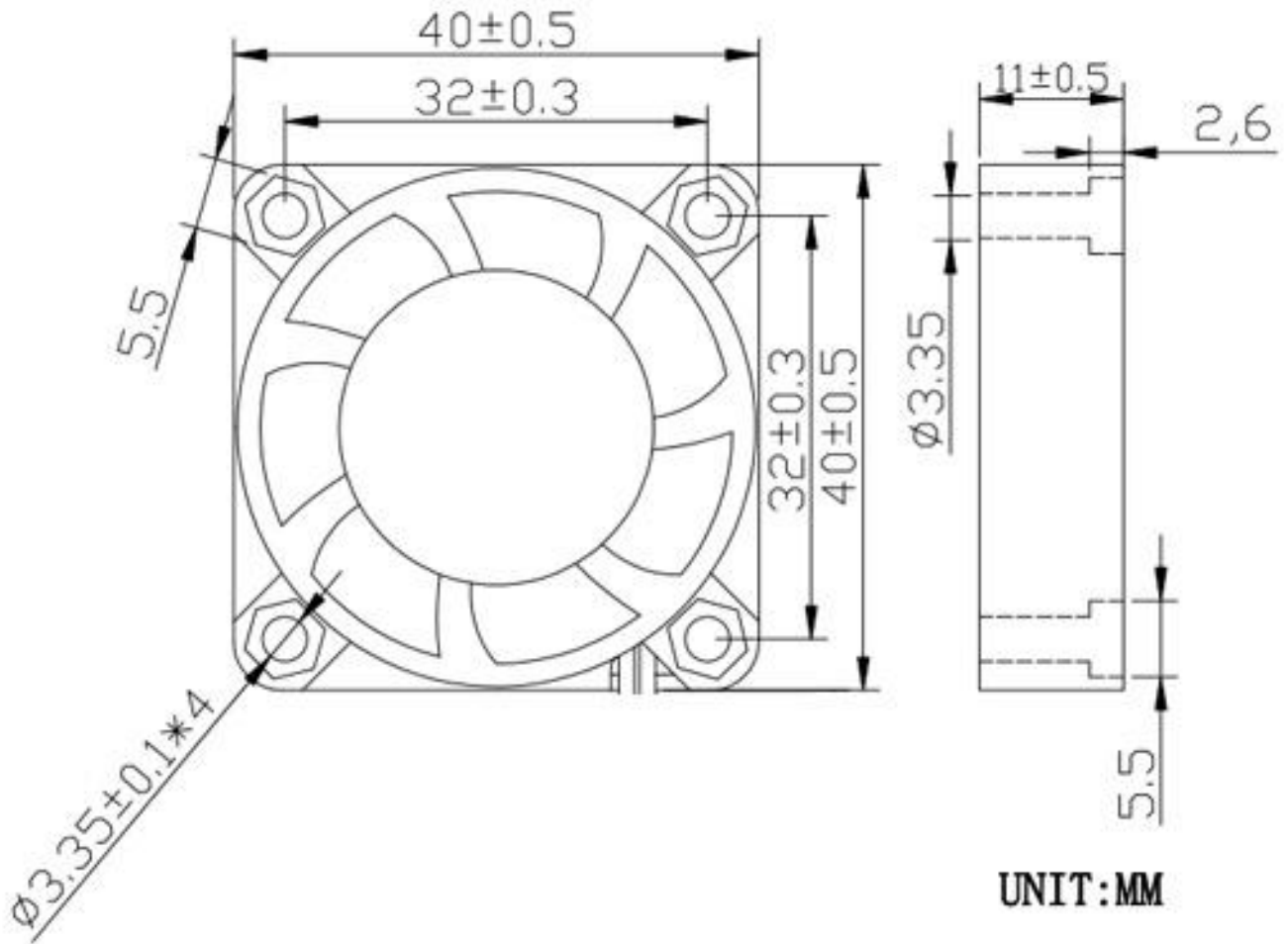

胜丰电子有限公司

SHENGFENG ELECTRONICS CO.,LTD

400-9920-988

制图: 陈卿伟

www.fancool.net

审核: 陈惠

8.0 商标 (Label Marking)

<p>20mm</p> 	型号/Model No.	MF4010SM12
	额定电压/Rated Voltage	12V DC
	标签电流/Label Current	0.15A
	标签尺寸/Label Size	
	说明/Explain	标签电流标识最大电流
	安规/Safety Approvals	CE
	附加码/Appendix Code	无/No

9. 注意事项 (Nores)

- 9-1. 使用时请勿超出本规定所规定之极限，否则我们不保证此产品
We, will nor guarantee the products if the application of our products are exceeded the limitation which isspecified on the specification
- 9-2. 倘若要变更此份文件任何规格，请务必事先提出要求
In case of changes of the specification specified on thid document A WRITTEN NOTICEIS REQUESTED INADVANCE
- 9-3. 请勿触压着叶片以电源线缠绕着风扇或用力拉扯电源线，如此轴心与电源线将会被损坏
please do not touch the impeller with the pressure and never bring the fan with lead wire The bearing and lead wiremay be damaged
- 9-4. 本产品不保证因粉尘、水滴、小虫进入，而影响寿命与不良产生
No guarantee on the products against the safety problem or failure caused by powder dust,drop of water or insect
- 9-5. 如有任何资料及文件与此份资料不同，将以此份资料为主要参考
If there is any data or related documentation different from this data sheet.This data sheet is the pr
inciple reference
- 9-6. 请勿在可燃性气体与任何有害环境中使用
please do not use the fan in the environment of corrosive gas or liquid or any detrimental gas
- 9-7. 请于六个月内使用，否则风扇存放在很高温或很低温及湿度很高的室温中，风扇于六个月后将可能会有漏电流产生
please do not store the fan in the environment of high/low temperarure,high humidity or detrimental gas.Pleasestore within six months,every six months,shall be a leakage of electric current to the fan,, even though the fan isstored in room temperature
- 9-8. 当风扇于运转中，请勿企图将风扇锁死特别长的时间，如此，会因连续停止不转，产生高热而烧毁风扇
while the fan is in operarion,please do not lock the fan intentionally for a long period of time,since the continuousstoppage will result in overheat and thus burnt out the fan..
- 9-9. 组装风扇时，请特别注意，因共振或振动产生的噪音
During the installation of the fan, please pay sudstantial attention to possible notice caused by resonance vibrationand shock
- 9-10. 当搬运或作业中，风扇如从 60cm 的高底落下，将会对叶片的平衡产生若干影响，特别是滚珠轴承避免掉落
It is very important to notify that avoid to drop fron 60cm height when in any movement or operation,it will impactthe balance ofblade.Especially ball bearing structure is avoided to drop down
- 9-11. 锁外壳之螺丝扭力不得超 4.6 kg -5.3 kg
The torque of the screw that locked the frame should not exceed 4.6kg-5.3kg



This certificate is responsible for testing sample only.
Please refer to this corresponding test report to get testing process and data.

CERTIFICATE

ATTESTATION Certificate of Compliance

Technical file of the company mentioned below has been inspected and audit has been completed successfully

The EMC Directive 2014/30/EU has been taken as references for these processes.

Certificate's Holder : SHENZHEN SHENGFENGHONG ELECTRONICS CO., LTD.
Address : Third floor, building a, Hetai Industrial Park, NO:6, Datang North Road, Xiawei village, Zhutang, Fenggang town, Dongguan City, China
Manufacturer : SHENGFENGHONG ELECTRONICS CO., LTD.
Address : No.1-2205 Yabao Rd., Bantian , Longgang Distict, Shenzhen, China
Product Name : cooling fan
Product Model (S) : SF12038, SF1504, SF1805, SF2006, SF2010, SF2507, SF2510, SF3007, SF3010, SF3507, SF3510, SF4007, SF4010, SF4015, SF4020, SF4028, SF4056, SF5010, SF5012, SF5015, SF5020, SF6010, SF6015, SF6020, SF6025, SF6038, SF7010, SF7015, SF7020, SF7025, SF7030, SF7530, SF8010, SF8015, SF8020, SF8025, SF8038, SF8076, SF9010, SF9015, SF9025, SF9038, SF9215, SF9225, SF9238, SF9733, SF10025, SF11025, SF12025, SF12032, SF14025, SF14038, SF15050, SF16038, SF16050, SF17238, SF17250, SF17251, SF18060, SF20060, SF22060, SF25489
Trade Mark : N/A
Related Directive : 2014/30/EU
Related Standards : EN 55032:2015 + A1:2020 + A11:2020
EN 55035:2017 + A11:2020
Certificate Number : HK2109183572E
Report No. : HK2109183572-1ER
Registration Date : Sep. 24, 2021



The information of the certificate can be checked through www.cer-mark.com. The CE mark which is shown on the certificate can only be used under the conditions that the products complete with all of the relevant Directives of EC Declaration of Conformity. The Manufacturer should be responsible for the internal production control so that the products complied with the essential requirements of the above mentioned Directive(s). Certificate holder must notify all changes to the original certification laboratory of HUAKE.



Shenzhen HUAKE Testing Technology Co., Ltd.

Address: 1-2/F., Building B2, Junfeng Zhongcheng Zhizao Innovation Park, Heping, Fuhai Street, Bao'an District, Shenzhen, Guangdong, China
Tel.: +86-755-2302 9901 Http:// www.cer-mark.com Postcode: 518103 E-mail: service@cer-mark.com



This certificate is responsible for testing sample only.
Please refer to this corresponding test report to get testing process and data.

CERTIFICATE

ATTESTATION Certificate of Compliance

Technical file of the company mentioned below has been inspected and audit has been completed successfully

The RoHS Directive 2015/863/EU amending Annex II to Directive 2011/65/EU has been taken as references for these processes.

Certificate's Holder : SHENZHEN SHENGFENGHONG ELECTRONICS CO., LTD.
 Address : Third floor, building a, Hetai Industrial Park, NO:6,
 Datang North Road, Xiawei village, Zhutang,
 Fenggang town, Dongguan City, China

Manufacturer : SHENZHEN SHENGFENGHONG ELECTRONICS CO.,LTD.
 Address : No.1-2205 Yabao Rd., Bantian, Longgang Distict, Shenzhen China

Product Name : cooling fan
 SF12038, SF1504, SF1805, SF2006, SF2010, SF2507, SF2510, SF3007,
 SF3010, SF3507, SF3510, SF4007, SF4010, SF4015, SF4020, SF4028,
 SF4056, SF5010, SF5012, SF5015, SF5020, SF6010, SF6015, SF6020,
 SF6025, SF6038, SF7010, SF7015, SF7020, SF7025, SF7030, SF7530,
 SF8010, SF8015, SF8020, SF8025, SF8038, SF8076, SF9010, SF9015,
 SF9025, SF9038, SF9215, SF9225, SF9238, SF9733, SF10025, SF11025,
 SF12025, SF12032, SF12038, SF14025, SF14038, SF15050, SF16038,
 SF16050, SF17238, SF17250, SF17251, SF18060, SF20060, SF22060,
 SF25489

Product Model (S) : SF8010, SF8015, SF8020, SF8025, SF8038, SF8076, SF9010, SF9015,
 SF9025, SF9038, SF9215, SF9225, SF9238, SF9733, SF10025, SF11025,
 SF12025, SF12032, SF12038, SF14025, SF14038, SF15050, SF16038,
 SF16050, SF17238, SF17250, SF17251, SF18060, SF20060, SF22060,
 SF25489

Trade Mark :
 Related Directive : Directive 2015/863/EU amending Annex II to Directive 2011/65/EU

Certificate Number : HK2109183877R
 Report No. : HK2109183877-1RR
 Registration Date : October 09, 2021



The information of the certificate can be checked through www.cer-mark.com. The CE mark which is shown on the certificate can only be used under the conditions that the products complete with all of the relevant Directives of EC Declaration of Conformity. The Manufacturer should be responsible for the internal production control so that the products complied with the essential requirements of the above mentioned Directive(s). Certificate holder must notify all changes to the original certification laboratory of HUAKE.



Shenzhen HUAKE Testing Technology Co., Ltd.

Address: 1-2/F., Building B2, Junfeng Zhongcheng Zhizao Innovation Park, Heping, Fuhai Street, Bao'an District, Shenzhen, Guangdong, China
Tel.: +86-755-2302 9901 Http://www.cer-mark.com Postcode: 518103 E-mail: service@cer-mark.com